

UM-X

Measurement evaluation unit in field housing



Version: 7
Edition: 2021-04
Art. no.: 207120

Table of Contents

1	Characteristics of the measurement evaluation unit UM-X.....	1
2	Safety Instructions	2
2.1	Password	2
3	Design and Function	3
3.1	Name plate	3
3.2	Buttons.....	3
3.3	Display Window	3
3.4	Alarm Light	4
3.5	Buzzer	4
4	Installation	5
4.1	Assembly and Connections	5
4.2	Pin Assignment	6
4.2.1	Sensor Connection.....	6
4.2.2	Output Circuits	7
4.2.3	Power Supply	7
4.2.4	External Acknowledge Button	7
5	Commissioning	7
6	Operation	9
6.1	Layout of the display.....	9
6.1.1	Digital display	9
6.1.2	Multi-function field.....	9
6.1.3	Button function field	9
6.2	Column Display (Analogue Display).....	10
6.3	Relay Status Display	10
6.4	Main Menu	11
6.4.1	Navigation.....	11
6.4.2	Password	12
6.4.3	Switch-on the Backlight.....	12
6.5	Unit Menu	13
6.6	Height Menu	14

6.7	Offset Menu (Zero-Point Displacement)	15
6.8	Span menu (measuring range).....	16
6.8.1	Span - Change.....	16
6.8.2	Span - Reset.....	17
6.9	Relays Menu.....	18
6.9.1	Relays - K1 ... K5.....	18
6.9.2	S-P On (Switching Point On).....	19
6.9.3	S-P Off (Switching Point Off)	20
6.9.4	On Delay (switching on delay)	20
6.9.5	Off Delay (switching off delay).....	21
6.9.6	Alarm	21
6.9.7	Acknowledge Menu	22
6.10	Test Menu	23
6.11	Display Menu.....	24
6.11.1	Brightness	24
6.11.2	Off Delay.....	25
6.11.3	On Delay.....	25
6.12	Reset Menu	26
6.13	Info Display.....	26
6.14	Menu structure with factory setting.....	27
6.15	Alarms	29
6.15.1	Relay alarm.....	29
6.15.2	Error.....	29
6.15.3	Meaning of the error codes	29
7	Maintenance	30
7.1	Servicing	30
7.2	Return shipment.....	30
8	Technical Data.....	30
9	List of Figures	31
10	Annex	32
10.1	EU Declaration of Conformity	32
10.2	EC-Type Examination Certificate	33
10.2.1	Supplement	35
10.2.2	Instructions.....	38



© Copyright:

Reproduction and translation are permitted only with the written consent of the FAFNIR GmbH. The FAFNIR GmbH reserves the right to carry out product alterations without prior notice.

1 Characteristics of the measurement evaluation unit UM-X

The measurement evaluation unit UM-X is a stand-alone filling level display for continuous level sensors. It is directly driven from the power supply and serves at the same time as a power supply for the level sensor. The filling level can be presented in both analogue and digital form on the graphic display.

The measurement evaluation unit UM-X also provides five potential-free changeover contacts. The switching points for the five relays are set via 4 display buttons and the state of the relays is shown on the display.

The measurement evaluation unit UM-X

- can be used for any level sensors with a 4-20 mA interface
- can be supplied with ATEX approval (intrinsically safe electrical circuit)
- can be supplied as an approved overfill protection device (see manual Overfill Protection, German, art. no. 207124)
- displays the filling level in digital and analogue form
- has five potential-free changeover contacts as binary outputs
- offers an easy menu-based operation via a graphic display
- is installed in a splash-proof housing

There are 4 versions of the measurement evaluation unit UM-X:

UM-S

Standard version: Evaluation unit with 5 relay outputs and connector for a continuous level sensor and for an external acknowledge button.

UM-O

Evaluation unit with 5 relay outputs and connector for a continuous level sensor and for an external acknowledge button.

Approved as an overfill protection device.

UM-Ex

Evaluation unit with 5 relay outputs and connector for a continuous level sensor and for an external acknowledge button.

Approved for the connection of an explosion-proof sensor (intrinsically safe sensor circuit).

UM-O Ex

Evaluation unit with 5 relay outputs and connector for a continuous level sensor and for an external acknowledge button.

Approved as an overfill protection device and for the connection of an explosion-proof sensor (intrinsically safe sensor circuit).

2 Safety Instructions

The measurement evaluation unit UM-X is a stand-alone filling level display for continuous level sensors. Use the system exclusively for this purpose. The manufacturer accepts no liability for any form of damage resulting from improper use.

The measurement evaluation unit UM-X has been developed, manufactured and tested in accordance with the state-of-the art technology and the generally accepted safety standards. Nevertheless, hazards may still arise. For this reason, the following safety instructions must be observed:

- Do not change or modify the system or add any equipment without the prior consent of the manufacturer.
- All installation and maintenance work, with the exception of functional testing, must be carried out with the power disconnected.
- The measurement evaluation unit UM-X must be installed outside the potentially explosive area.
- The installation, operation and maintenance of the measurement evaluation unit UM-X must be carried out only by expert personnel. Specialised knowledge must be acquired by regular training.
- Operators, installers and service technicians must comply with all applicable safety regulations. This also applies to any local safety and accident prevention regulations which are not stated in this guide.

The safety instructions in this user guide are marked as follows:



If these safety instructions are not observed, it may result in the risk of accident or damages to the system.



Useful information which ensures continued and correct operation of equipment and makes your work easier.

2.1 Password



You will need a password for certain menu options in order to be able to access or amend the points in question.



The password will be advised on an attached sheet and may only be used by trained personnel!

3 Design and Function

3.1 Name plate

The name plate contains e.g. the version of your measurement evaluation unit:

- Device type UM-S, UM-O, UM-Ex or UM-O Ex
- Approvals

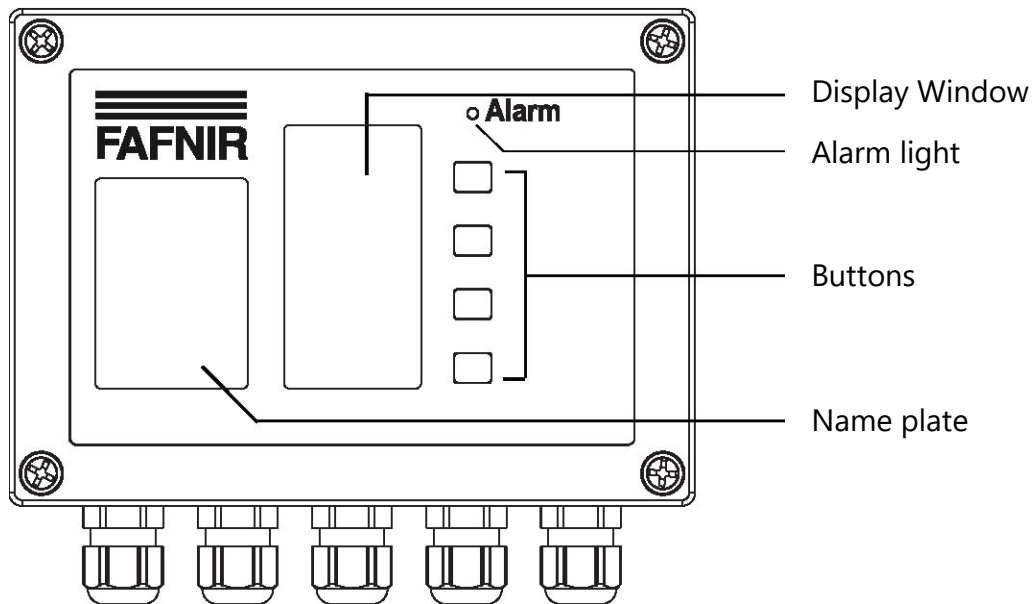

Figure 1: Design of the measurement evaluation unit UM-X, view from above

3.2 Buttons

With the four buttons you can navigate through the menu structure and configure the measurement evaluation unit.

The function of these buttons is shown in the function-button field of the display and changes partly in the individual menus (see Section 6.1 „Layout of the display“).

3.3 Display Window

The display shows the filling level information and is used to adjust the parameters for the measurement evaluation unit.

3.4 Alarm Light

The measurement evaluation unit is equipped with a red LED "Alarm" to display alarms and system faults.

The red LED indicates if the alarm thresholds have been exceeded or fallen below or if faults have occurred (see Section 6.15 „Alarms“).

3.5 Buzzer

The buzzer provides acoustic alarm messages. The alarm sound is interrupted as soon as the acknowledge button has been pressed, the cause of the alarm or the fault have been eliminated. The loudness of the buzzer cannot be adjusted.

4 Installation



The installation must be carried out only by expert personnel and in accordance with all applicable safety regulations. This also applies to any local safety and accident prevention regulations which are not stated in this guide.

4.1 Assembly and Connections

The measurement evaluation unit UM-X is designed to be wall-mounted. It can only be mounted and connected in opened condition:

- (1) Loosen the four cover screws.
- (2) Carefully remove the cover. It is still connected with the circuit board by means of two ribbon cables.
- (3) Remove the plugs in order to enable the cover to be completely removed.
- (4) Now you can mount the measurement evaluation unit.



The measurement evaluation unit must be installed outside the potentially explosive area.

- (5) After mounting, connect the cables for the power supply and the level sensor to the measurement evaluation unit. You can optionally connect an external acknowledge button and external control devices (see Section 4.2 „Pin Assignment“).

After mounting and connecting all electrical lines, close the measurement evaluation unit again:

- (6) First, carefully plug the wide ribbon cable back into its holder, which is protected against polarity reversal.
- (7) Now reconnect the membrane keyboard with the narrow ribbon cable. Pay particular attention here to the correct seating of the socket as this does not have reverse polarity protection.
- (8) Close the measurement evaluation unit with the four cover screws.

4.2 Pin Assignment

 *The wiring must be carried out only with the power disconnected. Special local rules and regulations of relevant Professional Associations and Authorities must be observed (e.g. VDE in Germany).*

 *Observe the maximum values of the operating parameters that are stated in the Technical Specifications.*

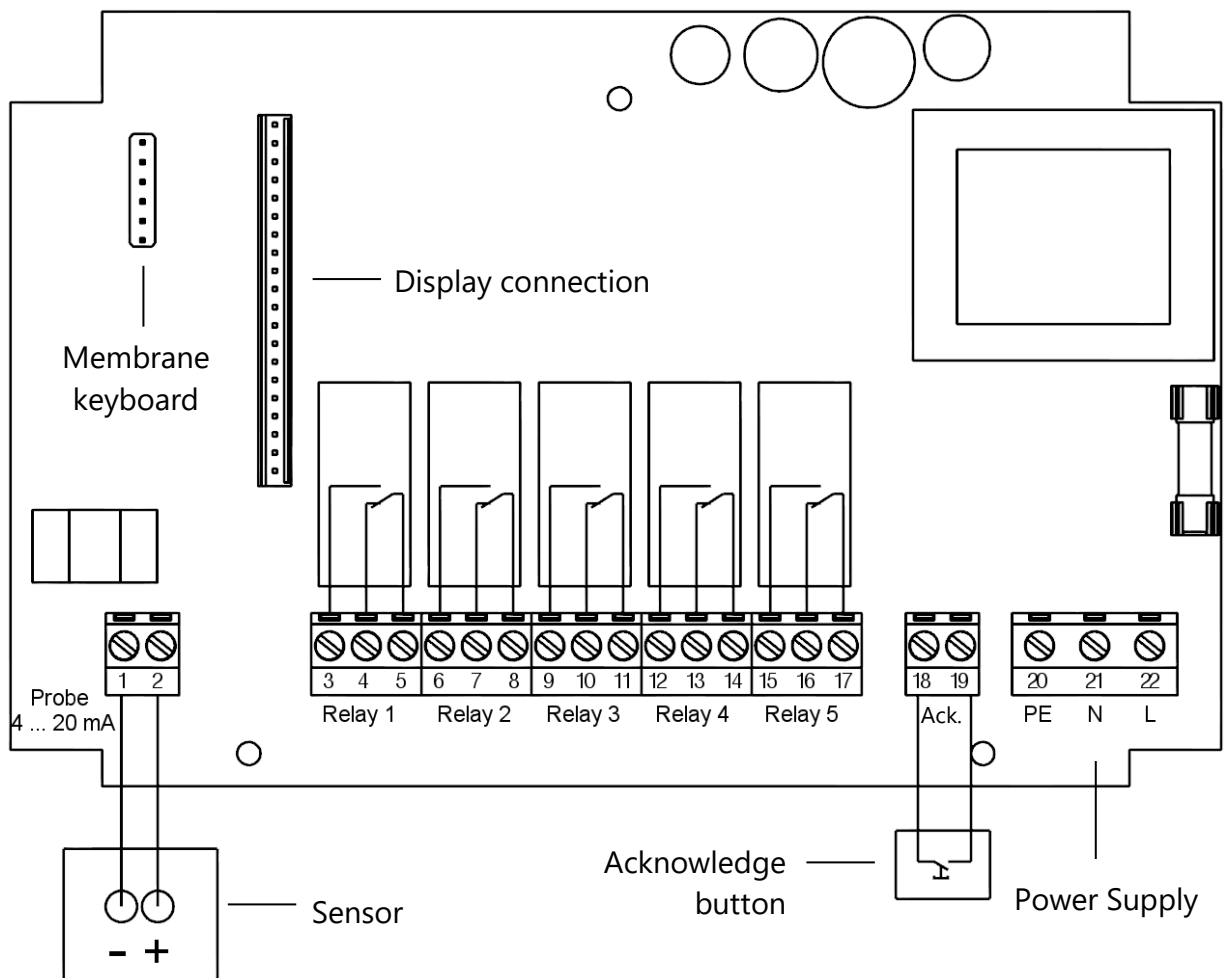

Figure 2: Evaluation unit UM-X, pin assignment

4.2.1 Sensor Connection

The sensor is connected to the terminals 1 (-) and 2 (+).

4.2.2 Output Circuits

The relays K1 to K5 (terminals 3 to 17) serve as limit signal indicators. There are 5 potential-free changeover contacts.



Special features of the UM-O and UM-O Ex versions of the device:

- Non-acknowledgeable overflow protection relays:
Relays K1 (terminals 3,4 and 5)
- Acknowledgeable overflow protection relays:
Relays K2 (terminals 6, 7 and 8)

4.2.3 Power Supply

The power supply is connected to the terminals PE, N and L of the circuit board. In the 24 VDC version + must be connected to L and - to N.

4.2.4 External Acknowledge Button

An external acknowledge button (potential-free NO) can be used. This is connected to the terminals "Ack." (18 and 19).



CAUTION MAINS VOLTAGE!

5 Commissioning

The measurement evaluation unit is supplied with a factory setting (default) and must be adapted to the local conditions.



Detailed information for the setting of the measurement evaluation unit can be found in Section 6 „Operation“.



The values of the factory settings are listed in Section 6.14 „Menu structure with factory setting“.

For commissioning of the system proceed as follows:

- (1) Attach the measurement evaluation unit UM-X to its intended location and insert the filling-level sensor into the container (see also Section 4).
- (2) Connect at least the power supply and the sensor.
- (3) During the assembly, ensure that the ribbon cables from the display and from the membrane keyboard are correctly connected before the measurement evaluation unit is closed.

- (4) Now switch on the power supply.
- (5) Set the 4-mA-point (bottom) and the 20-mA-point (top, container height) on the level sensor.
- (6) Now go to the measurement evaluation unit menu. Select the "Height" item and enter the container height.
- (7) If the 4-mA-point is not at the height of the tank bottom, then set the correct level in the "Offset" menu.
- (8) If the 20-mA-point does not correspond to the container height
 - fill your container as full as possible (the 20-mA-point must be above the container height!),
 - then measure the filling height with a dipstick,
 - and enter the value in the "Span - Change" menu point.



The 20-mA-point must not be below the container height. With the device variants UM-O and UM-O Ex (overflow protection devices), the 20-mA-point must correspond to the container height.

- (9) Now you can set the relay switching points.



Changing the offset or the span factor can cause a switching point below 4 mA or above 20 mA. In that case the relays do not switch as desired and malfunctions can occur.



Check the current values in the menu items "Relays -> K1...K5 -> S-P On and S-P Off". If the current values are outside of the desired range, "< 4.00 mA" or "> 20.00 mA" is displayed under the milliampere unit.

6 Operation

The message "Info" appears for 5 seconds on display after switching on the measurement evaluation unit. The display then changes automatically to the filling level display in column form. An overview of the menu structure and the factory-set default values can be found in Section 6.14 „Menu structure with factory setting“.



Figure 3: Display after switching on the measurement evaluation unit

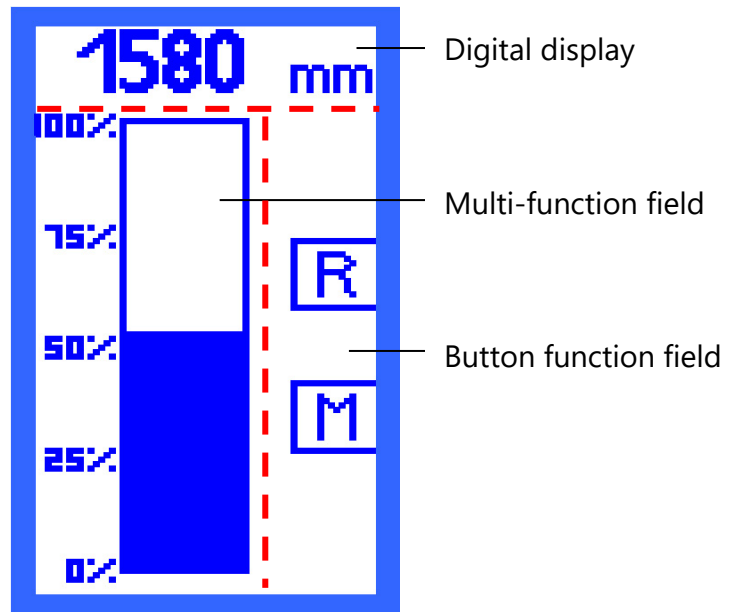

Figure 4: Layout of the display
Column display

6.1 Layout of the display

The display is divided into 3 areas (see Figure 4):

6.1.1 Digital display

The current filling level is digitally displayed in the top line.

6.1.2 Multi-function field

The information field has the following functions:

- Analogue display of the filling level or of the relay status.
- Navigation via the menu:
Navigating through the menu structure using buttons.

6.1.3 Button function field

The right column of the display serves as the button function field. The functions of the adjacent buttons are displayed here. The functions are matched with the respective menu options.

6.2 Column Display (Analogue Display)

The column shows the filling level graphically. The scaling is in percent and cannot be changed. The filling level is also displayed digitally (see Figure 4).

There are two possible ways of navigating in the column display:

- Symbol [R] - shows the status of all relays
- Symbol [M] - returns to the main menu

6.3 Relay Status Display

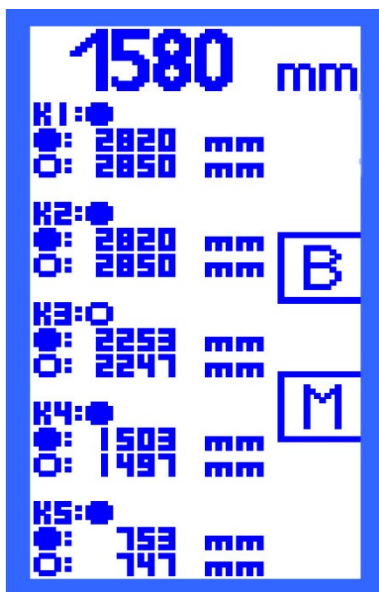

The relay status display gives an overview of the current status of all relays:

- A filled point indicates the status "relay activated".
- An open point indicates the status "relay deactivated".

At the same time, you have an overview of the switching points of the relays which you set in the "S-P On" and "S-P Off" menu points.

The symbol

[B] - leads to the column display ("bar graph").

[M] - returns to the main menu.

Figure 5: Relay Status Display

6.4 Main Menu

The main menu is called up from the "Column display" or "Relay status" display with the button next to the symbol [M].

You may select the following menu items:

- Unit - Setting the unit
- Height - Setting the container height
- Offset - Setting the distance from the container bottom to the 4-mA-point of the level sensor
- Span - Selection menu for sensor adjustments, e.g. pressure sensors
- Relays - Selection menu for configuring the relays
- Test - Selection menu for manual control of the relays
- Display - Selection menu for adjusting the display backlight
- Reset - Selection menu for resetting of all values to the factory setting
- Info - Display of device information

If you are in a menu for more than 3 minutes without making any further inputs, the display automatically returns to the last view - column presentation or relay status. Changes to parameters, which have not been confirmed are not saved.

6.4.1 Navigation

There are four functions available for scrolling through the different menu items, for calling up the selected menu item and for saving changed parameters.

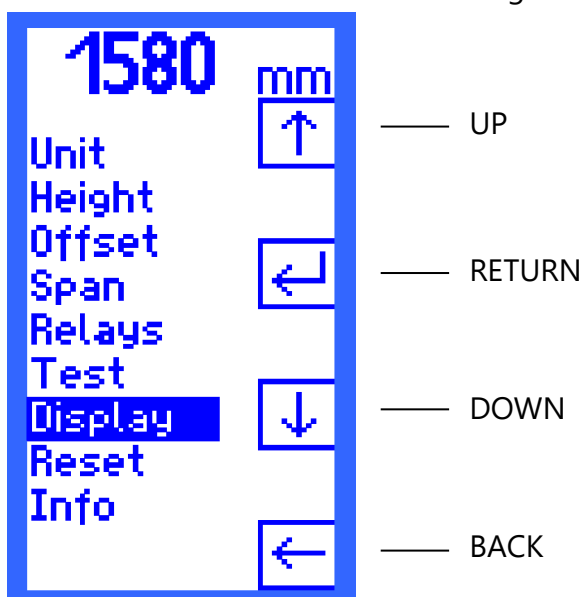

Figure 6: Main menu with navigation functions

Cursor UP [↑] and Cursor DOWN [↓]

The cursor is moved through the menus with the functions UP [↑] or DOWN [↓] shown on the display. This is how to select the menu items.

RETURN [↵]

The RETURN symbol [↵] has two functions:

- "Confirm"
In the menu selection, you confirm your selection with RETURN [↵] and call up a submenu.
- "Save and Return"
If you have changed parameters in a menu, you save your entries with RETURN [↵]. After saving, the next higher-level menu is automatically displayed.

BACK [←]

The BACK symbol [←] has two functions:

- "Back without selecting"
In the menu selection you can jump back one level up with BACK [←].
- "Back without saving"
If you have changed parameters in a menu, you can quit the menu item with BACK [←] without saving the new settings.

6.4.2 Password

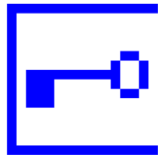

In the case of menu items, in which the password must be entered, a key is displayed instead of the Enter button.

6.4.3 Switch-on the Backlight

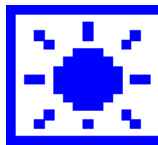

If the backlight is reduced to the set minimum, the lamp button is displayed in the button function field.

When you press the lamp button, the backlight is switched on again and you can continue to operate the device.

6.5 Unit Menu

When the menu "Unit" is called up, the cursor automatically lies on the currently set unit. The following units are available for selection

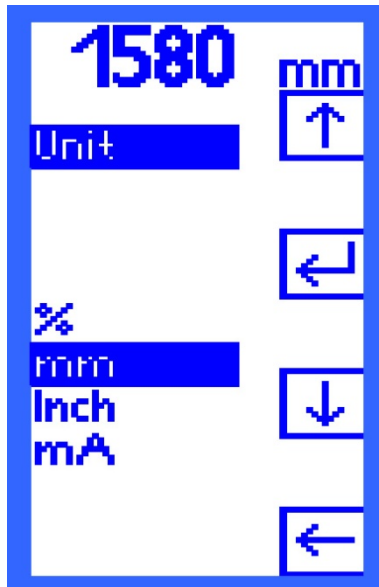

% - Percent

mm - Millimetre

Inch - Inch (unit specification on the display with <">)

mA- Milliampere

Select with the Functions

UP [↑] and

DOWN [↓]

the desired unit.

Confirm your selection with RETURN [↵].

The selected unit is used for the values in the data field and in the "Relay status" display.

Figure 7: "Unit" display

6.6 Height Menu

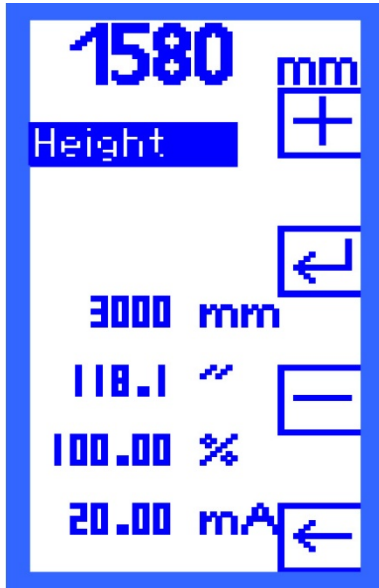

Enter the container height in the "Height" menu.

The height can be up to 25000 mm and is set in 1-millimetre steps. The units inches, percent and milliamperes are calculated and displayed for information.

Enter with the functions

[+] PLUS and

[-] MINUS

the corresponding value.

Confirm your entry with RETURN [↵].

Figure 8: "Height" display



With the device variants UM-O and UM-O Ex (overflow protection devices) you need a password to change the container height.



The 20-mA-point of the level sensor must be set to the container height. If this is not be possible, an adjustment can be made with the "Span" menu item.

6.7 Offset Menu (Zero-Point Displacement)

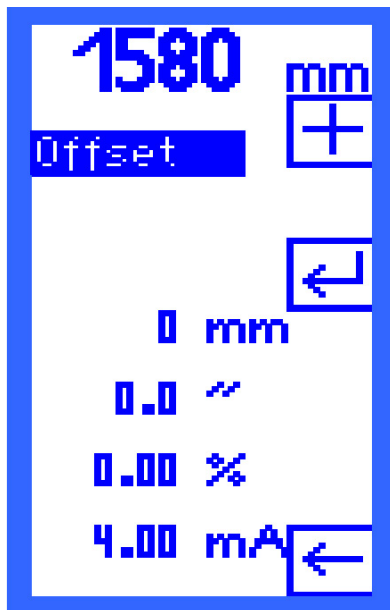

The distance from container bottom up to the 4-mA-point of the level sensor is called the "Offset".

The distance is set in 1-millimetre steps. The units inches, percent and milliamperes are calculated and displayed for information.

Enter with the functions

[+] PLUS and

[-] MINUS

the desired value.

Confirm your entry with RETURN [↵].

Figure 9: "Offset" display



Changing the offset can cause a switching point below 4 mA or above 20 mA. In that case the relays do not switch as desired and malfunctions can occur.



Check the current values in the menu items "Relays -> K1...K5 -> S-P On and S-P Off". They must not be below 4 mA and not above 20 mA.

Example:

The container height is set to 3000 mm and the offset is set to 300 mm - which corresponds to 10%. Since the relay switching points are set in percentage, these points can also be below 10% and therefore less than 4 mA.



With the device variants UM-O and UM-O Ex (overflow protection devices) you need a password to change the container height.

6.8 Span menu (measuring range)

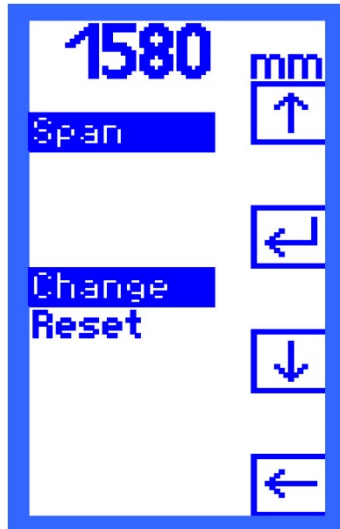

If you use a sensor for the fill level measurement with a 20-mA-point which does not match the container height (for example pressure sensors), adjust the sensor in the "Span" menu. In this menu you have two options:

- Change and
- Reset.

Select with the functions

UP [↑] and
DOWN [↓]

the desired option.

Confirm your selection with RETURN [↵].

Figure 10: "Span" display



With the device variants UM-O and UM-O Ex (overflow protection devices) you need a password to change the container height.

6.8.1 Span - Change

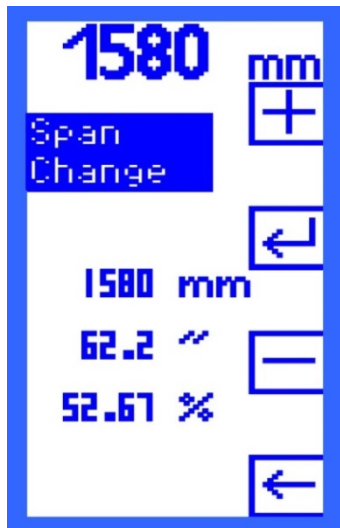

With the "Change" option, the level of the 20-mA-point can be changed.

The filling level is set in 1-millimetre steps. The units inches, percent and milliamperes are calculated and displayed for information.

Enter with the functions

[+] PLUS and [-] MINUS

the previously measured level.

The change can only be made during operation. The container must correctly be filled and the correct container height must be entered, so that deviations remain small. You will find detailed instructions in Section 5 „Commissioning“.

Figure 11: "Change" display



Changing the Span can cause a switching point below 4 mA or above 20 mA. In that case the relays do not switch as desired and malfunctions can occur.



Check the current values in the menu items "Relays -> K1...K5 -> S-P On and S-P Off". These must not be below 4 mA and not above 20 mA.

6.8.2 Span - Reset

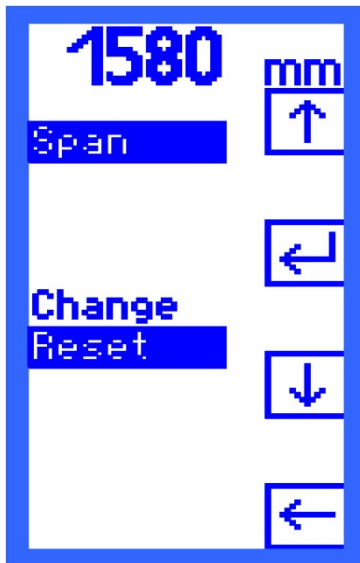

With the "Reset" option, you can reset changes of the measuring range back to the delivery status.

Confirm the "Reset" option with RETURN [↵]

Select the symbol

[Y] - for "Yes, reset" or

[N] - for "No, don't reset".

Figure 12: "Reset" display

6.9 Relays Menu

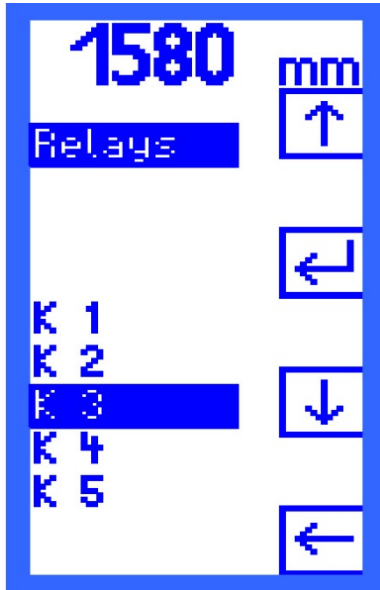

In the "Relays" menu you can select the individual relays K1 ... K5 for further configuration.

Select with the functions

UP [↑] and

DOWN [↓]

the desired relay.

Confirm your selection with RETURN [↵].

Figure 13: Relays Menu



With the device variants UM-O and UM-O Ex (overflow protection devices) you need a password to be able to select the relays K1 and K2. Relays K1 and K2 can only be selected and set together.

6.9.1 Relays - K1 ... K5

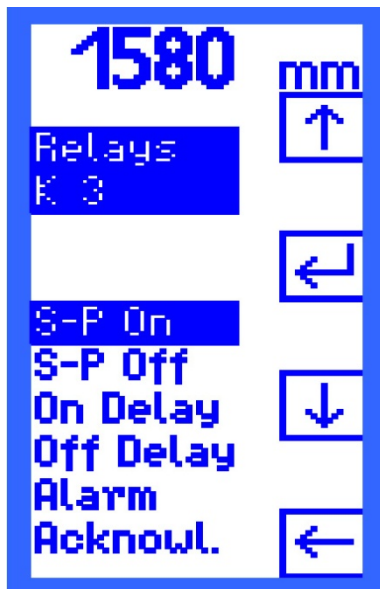

A menu opens for the selected relay in which you can make the following settings:

- S-P On - switching point on
- S-P Off - switching point off
- On Delay – switching on delay
- Off Delay – switching off delay
- Alarm - alarm configuration
- Acknowl. – Acknowledgement

With the functions

UP [↑] and

DOWN [↓]

select the desired setting.

Confirm your selection with RETURN [↵].

Figure 14: Relays K1 ... K5 Display

6.9.2 S-P On (Switching Point On)

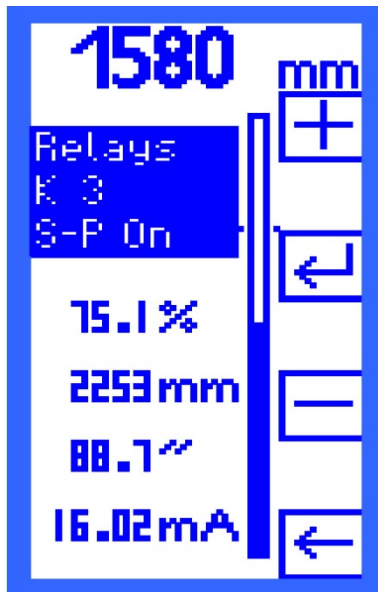

"S-P On" (Switching Point On) shows the value at which the relay activates.

The switching on point is set in 0.1 percent steps. The range of values is 0.1 to 99.9 percent. The units millimetres, inches and milliamperes are calculated and displayed for information.

Enter with the functions

[+] PLUS and

[-] MINUS

the desired value.

Confirm your entry with RETURN [↵].

Figure 15: "S-P On" display



The current value must not be below 4 mA and not above 20 mA so that a malfunction does not occur.



The range of values of the device variants UM-O and UM-O Ex for the K1/K2 relays is between 0.1 and 98.9 percent. The Switching Point On (S-P On) is always below the Switching Point Off (S-P Off) and can never exceed it.

6.9.3 S-P Off (Switching Point Off)

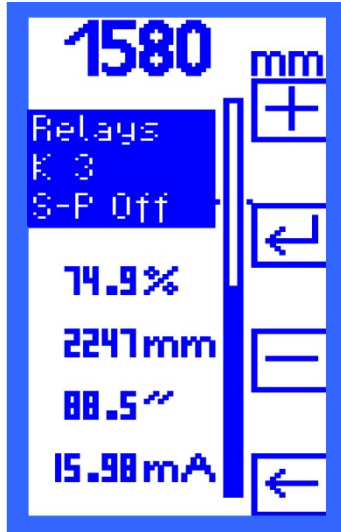

"S-P OFF" (Switching Point Off) shows the value at which the relay activates.

The switching off point is set in 0.1 percent steps. The range of values is 0.1 to 99.9 percent. The units millimetres, inches and milliamperes are calculated and displayed for information.

Enter with the functions

[+] PLUS and

[-] MINUS

the desired value.

Confirm your entry with RETURN [↵].

Figure 16: "S-P Off" Display



The current value must not be below 4 mA and not above 20 mA so that a malfunction does not occur.



The range of values of the device variants UM-O and UM-O Ex for the K1/K2 relays is between 0.2 and 99.0 percent. The Switching Point Off (S-P Off) is always above the Switching Point On (S-P On) and can never fall below it.

6.9.4 On Delay (switching on delay)

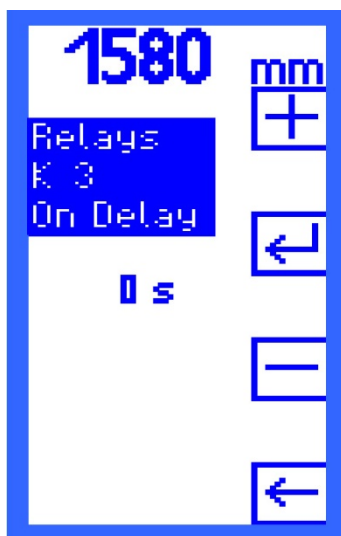

"On Delay" shows the switching on delay of the selected relay.

The delay time can be between 0 and 255 seconds and is set in 1 second steps.

Enter with the functions

[+] PLUS and

[-] MINUS

the desired value.

Confirm your entry with RETURN [↵].

Figure 17: "On Delay" display

6.9.5 Off Delay (switching off delay)



"OFF Delay" shows the switching off delay of the selected relay.

The delay time can be between 0 and 255 seconds and is set in 1 second steps.

Enter with the functions

[+] PLUS and

[-] MINUS

the desired value.

Confirm your entry with RETURN [↵].

Figure 18: "Off Delay" display



With the device variants UM-O and UM-O Ex (overflow protection devices), the switching off delay for the relays K1/K2 is always 0 seconds and cannot be changed.

6.9.6 Alarm



In the "Alarm" menu you can switch the relay alarm for the selected relay on or off.

Select with the functions

UP [↑] and

DOWN [↓]

On - Relay alarm on or

Off - Relay alarm off.

Confirm your selection with RETURN [↵].

See also Section 6.15 „Alarms“.

Figure 19: "Alarm" Display



In case of the versions UM-O and UM-O Ex (overflow protection devices), the alarm for the K1/K2 relays is always set and cannot be turned to "Off".

6.9.7 Acknowledge Menu



In the Acknowl. menu you can set for the selected relay whether it should be able to be acknowledged in the event of an alarm.

Select with the functions

UP [↑] and

DOWN [↓]

On - Relay can be acknowledged or

Off - Relay cannot be acknowledged.

Confirm your selection with RETURN [↵].

Figure 20: "Acknowl." display



In case of the versions UM-O and UM-O Ex (overflow protection devices), the acknowledgement for K1/K2 cannot be changed.

6.10 Test Menu

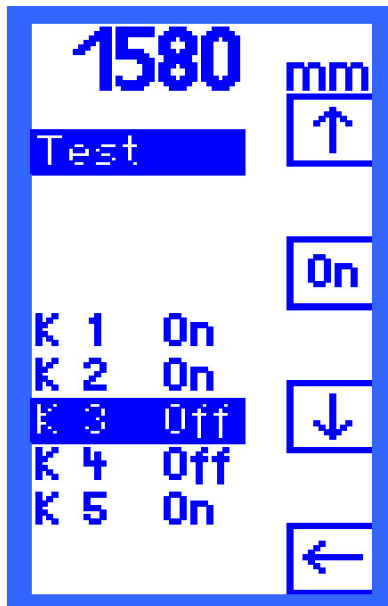

The "Test" menu gives you an overview of the five relays K1 to K5. It shows behind each relay with "On" or "Off" whether this is activated (On) or deactivated (Off).

Select relays:

You can select a relay using the UP [↑] and DOWN [↓] function.

Switch relays on and off:

Depending on the test status of a relay between the UP [↑] and DOWN [↓] appears the symbol

[On] - for "relay activated" or
[Off] - for "relay deactivated".

Figure 21: "Test" display.

A manually switched relay switches to the current operating status as soon as you select another relay or after quitting the "Test" menu-point.



In case of the versions UM-O and UM-O Ex (overflow protection devices), a test cannot be performed for the K1 or K2 relays when K1 is switched-off (relay alarm).



In the event of a fault (see Section 6.15.2 „Error“) all relays are automatically switched-off. A test may only be repeated when the fault is rectified.

6.11 Display Menu

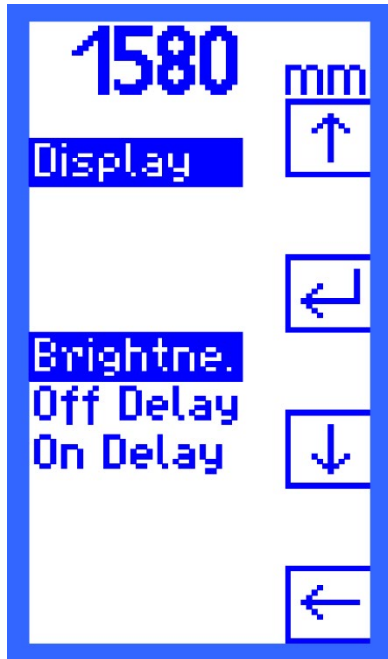

The brightness, the switch-off delay and the switch-on delay can be set to match the display to the working environment.

Select with the functions UP [↑] and DOWN [↓] the desired option and confirm your entry with RETURN [↵].

Figure 22: "Display"

6.11.1 Brightness

- Brightness Maximum

Adjust the brightness when the backlight is switched-on.

Default: 75.0 %

Minimum: 30.0 %

Maximum: 100.0 %

Step size: 0.1 %

The brightness changes when it is being adjusted

- Brightness Minimum

Adjust the brightness when the backlight is reduced.

Default: 10.0 %

Minimum: 0.0 %

Maximum: 30.0 %

Step size: 0.1 %



The brightness changes during the adjustment between Brightness Maximum and Brightness Minimum.

6.11.2 Off Delay

The afterglow of the display, for example when quitting the menu, is adjusted in the Off-Delay menu (switch-off delay).

Default:	60 s
Minimum:	0 s
Maximum:	255 s
Step size:	1 s

6.11.3 On Delay

The (automatic) switch-on of the backlight is set in the On-Delay menu (switch-on delay).

Default:	0 s*
Minimum:	0 s
Maximum:	255 s
Step size:	1 s

* Display does not switch-on again automatically.

6.12 Reset Menu

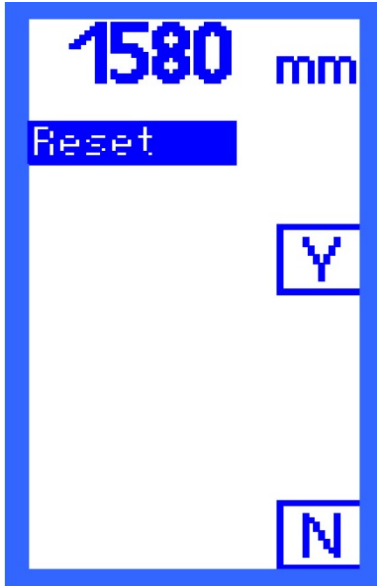

With "Reset" you replace all entries with the default factory settings. Select the function

[Y] - for "Yes, reset" or

[N] - for "No, don't reset" .



A password is required to call-up this menu

point!

Figure 23: "Reset" Display

6.13 Info Display



This menu item provides information about

- the device version,
- contact details of the manufacturer FAFNIR and the
- software version of the measurement evaluation unit.

You return to the main menu by pressing one of the four buttons.

Figure 24: "Info" display

6.14 Menu structure with factory setting

Start Display	Main Menu	Level 2	Level 3	Possible values	Factory setting
Bar graph presentation Relay status					
	Relays	K1	S-P On S-P Off On Delay Off Delay Alarm	0,1 ... 99,9 % 0,1 ... 99,9 % 0 ... 255 s 0 ... 255 s ON/OFF	94.0 % 95.0 % 0 s 0 s ON
		K2	S-P On S-P Off On Delay Off Delay Alarm	0,1 ... 99,9 % 0,1 ... 99,9 % 0 ... 255 s 0 ... 255 s ON/OFF	94.0 % 95.0 % 0 s 0 s OFF
		In the case of the UM-O and UM-O Ex versions, K1 and K2 are set together and a password is required.			
			S-P On	0,1 ... 98,9 % < S-P Off	94.0 %
			S-P Off	0,2 ... 99,0 % & > S-P On	95.0 %
			On Delay Off Delay Alarm	0 ... 255 s 0 s ON	0 s 0 s ON
		K3	S-P On S-P Off On Delay Off Delay Alarm	0,1 ... 99,9 % 0,1 ... 99,9 % 0 ... 255 s 0 ... 255 s ON/OFF	74.9 % 75.1 % 0 s 0 s OFF
		K4	S-P On S-P Off On Delay Off Delay Alarm	0,1 ... 99,9 % 0,1 ... 99,9 % 0 ... 255 s 0 ... 255 s ON/OFF	49.9 % 50.1 % 0 s 0 s OFF
		K5	S-P On S-P Off On Delay Off Delay Alarm	0,1 ... 99,9 % 0,1 ... 99,9 % 0 ... 255 s 0 ... 255 s ON/OFF	24.9 % 25.1 % 0 s 0 s OFF

Start Display	Main Menu	Level 2	Level 3	Possible values	Factory setting
	Unit			% mm inch mA	mm
	Height			1 ... 25.000 mm 0 ... 984,3 " 100 %	3,000 mm
A password is required for UM-O and UM-O Ex versions.					
	Offset			0 ... {Height} mm 0 ... {Height} " 0 ... 100,00 %	0 mm 0 " 0.00 %
A password is required for UM-O and UM-O Ex versions.					
	Span	Charge Reset		0 ... {Height} mm 0 ... {Height} " 0 ... 100,00 % Yes/No	
A password is required for UM-O and UM-O Ex versions.					
	Test	for each relay K1 ... K5		On/Off	
	Display	Brightness Maximum Brightness Minimum Off Delay On Delay		30,0 % ... 100.0 % 0,0 % ... 30,0 % 0 s ... 255 s 0 s ... 255 s	75.0 % 10.0 % 60 s 0 s
	Reset			Yes/No	
A password is required for all UM-X versions.					
	Info				

6.15 Alarms

6.15.1 Relay alarm

A relay alarm is an over or under threshold limit value which you set. If a relay is deactivated and at the same time the alarm has been set for this relay, then an alarm is triggered.

In the event of an alarm, the LED flashes at equal intervals (1 sec. on, 1 sec. off) and the buzzer sounds. The symbol [Q] appears on the display beside the lowest operating button. You acknowledge the alarm here.

When you acknowledge the alarm, the buzzer is switched off and the LED is continuously illuminated. The [Q]-symbol is the displayed inverted. The LED will no longer be illuminated and the (inverted) [Q] symbol displayed only when the cause of the alarm has been rectified.

6.15.2 Error



In the event of a fault, the LED flashes periodically (0.1 sec. on; 0.9 sec. off), a buzzer sounds, and the error code is shown on the display.

All relays are automatically deactivated in the event of an error and the [Q] symbol can be seen beside the lowest operating button. You acknowledge the alarm here.

The buzzer stops after the acknowledgement, but the LED continues to flash until the fault is rectified. The device is only accepted as being error-free when the fault is rectified, and no further fault has occurred after 10 seconds. In the meantime, the "ERROR 0" fault code is displayed.

The display then returns to the bar graph or relay status display - depending on which one you last had shown on the display.

Figure 25: "Error 2" display

6.15.3 Meaning of the error codes

The following faults can occur:

ERROR 1: Current fault on the filling level sensor (3.6 mA or 21,5 mA).

ERROR 2: Interruption in the sensor electric circuit, e.g. cable breakage.

ERROR 3: Short circuit in the sensor electric circuit.

ERROR 4: Internal device fault.

ERROR 0: Status between rectification of the fault and 10 seconds of the absence of any fault.

7 Maintenance

7.1 Servicing

FAFNIR devices are generally maintenance-free.

Only the probes in light liquid separators must be cleaned regularly every 6 months. This can be done e. g. during the prescribed six-monthly maintenance of light liquid separators.

7.2 Return shipment

Before returning any FAFNIR devices, the Return Material Authorization (RMA) is required. Please contact your Account Manager or the Technical Support for more information on returning goods.

Telephone	+49/40/39 82 07-0
Open (CET)	Mon. to Thu. 07:00 a.m. to 05:00 p.m., Fri. 07:00 a.m. to 04:00 p.m.



The return of FAFNIR devices is possible only with authorization (RMA) by the FAFNIR Technical Support.

8 Technical Data

Ambient temperature	- 20 °C ... +50 °C
Index of protection	IP64
Dimensions (WxHxD)	180 mm × 130 mm × 52 mm
Power Supply	230 VAC ±10 %, 50 – 60 Hz, 7.5 VA, or 115 VAC ±10 %, 50 – 60 Hz, 7.5 VA, or 24 VAC ±10 %, 50 – 60 Hz, 7.5 VA, or 24 VAC ±20 %, 4.7 W
Sensor circuit	4 to 20 mA
Voltage	$U \leq 27 \text{ V}$
Current	$I \leq 30 \text{ mA}$
Output	Five relays each with potential-free changeover contact
AC voltage	$U \leq 250 \text{ V}$; $I \leq 5 \text{ A}$; $P \leq 100 \text{ VA}$; $\cos \varphi \geq 0.7$
DC voltage	$U \leq 250 \text{ V}$; $I \leq 0.25 \text{ A}$; $P \leq 50 \text{ W}$
External Acknowledge Button	Potential-free NO present in the power supply



In addition, the technical data specified in the EU-type examination certificate and the operating instructions must be observed (see appendix).

9 List of Figures

Figure 1: Design of the measurement evaluation unit UM-X, view from above	3
Figure 2: Evaluation unit UM-X, pin assignment	6
Figure 3: Display after switching on the measurement evaluation unit	9
Figure 4: Layout of the display Column display	9
Figure 5: Relay Status Display	10
Figure 6: Main menu with navigation functions	11
Figure 7: "Unit" display	13
Figure 8: "Height" display	14
Figure 9: "Offset" display	15
Figure 10: "Span" display	16
Figure 11: "Change" display	16
Figure 12: "Reset" display	17
Figure 13: Relays Menu	18
Figure 14: Relays K1 ... K5 Display	18
Figure 15: "S-P On" display	19
Figure 16: "S-P Off" Display	20
Figure 17: "On Delay" display	20
Figure 18: "Off Delay" display	21
Figure 19: "Alarm" Display	21
Figure 20: "Acknowl." display	22
Figure 21: "Test" display	23
Figure 22: "Display"	24
Figure 23: "Reset" Display	26
Figure 24: "Info" display	26
Figure 25: "Error 2" display	29



**EU-Konformitätserklärung
EU Declaration of Conformity
Déclaration UE de Conformité**

**FAFNIR GmbH
Bahrenfelder Straße 19
22765 Hamburg / Germany**

erklärt als Hersteller in alleiniger Verantwortung, dass das Produkt
declares as manufacturer under sole responsibility that the product
déclare sous sa seule responsabilité en qualité de fabricant que le produit

**Messauswertung
Evaluation Unit
Unité d'analyse**

UM-...

den Vorschriften der europäischen Richtlinien
complies with the regulations of the European directives
est conforme aux réglementations des directives européennes suivantes

2011/65/EU	Beschränkung der Verwendung bestimmter gefährlicher Stoffe in Elektro- und Elektronikgeräten	RoHS
2011/65/EU	Restriction of the use of certain hazardous substances in electrical and electronic equipment	RoHS
2011/65/UE	Limitation de l'utilisation de certaines substances dangereuses dans les équipements électriques et électroniques	RoHS
2014/30/EU	Elektromagnetische Verträglichkeit	EMV
2014/30/EU	Electromagnetic compatibility	EMC
2014/30/UE	Compatibilité électromagnétique	CEM
2014/34/EU	Geräte und Schutzsysteme zur bestimmungsgemäßen Verwendung in explosionsgefährdeten Bereichen	ATEX
2014/34/EU	Equipment and protective systems intended for use in potentially explosive atmospheres	ATEX
2014/34/UE	Appareils et systèmes de protection destinés à être utilisés en atmosphères explosibles	ATEX
2014/35/EU	Bereitstellung elektrischer Betriebsmittel zur Verwendung innerhalb bestimmter Spannungsgrenzen auf dem Markt	NSRL
2014/35/EU	Making available on the market of electrical equipment designed for use within certain voltage limits	LVD
2014/35/UE	Mise à disposition sur le marché du matériel électrique destiné à être employé dans certaines limites de tension	DBT

durch die Anwendung folgender harmonisierter Normen entspricht
by applying the harmonised standards
par l'application des normes

RoHS / RoHS / RoHS	EN 50581:2012
EMV / EMC / CEM	EN 61326-1:2013
ATEX / ATEX / ATEX	EN 60079-0:2009
	EN 60079-11:2007
	EN 60079-26:2007
NSRL / LVD / DBT	EN 61010-1:2010

Das Produkt ist bestimmt als Elektro- und Elektronikgerät der RoHS-
The product is determined as electrical and electronic equipment of RoHS
Le produit est déterminés comme des équipements électriques et électroniques de RoHS

Kategorie / Category / Catégorie **Überwachungs- und Kontrollinstrumenten in der Industrie /
Industrial Monitoring and Control Instruments /
Instruments de contrôle et de surveillance industriels**

Das Produkt entspricht den EMV-Anforderungen
The product complies with the EMC requirements
Le produit est conforme aux exigences CEM

Störaussendung / Emission / Émission **Klasse B / Class B / Classe B**
Störfestigkeit / Immunity / D'immunité **Industrielle elektromagnetische Umgebung /
Industrial electromagnetic environment /
Environnement électromagnétique industriel**

Die notifizierte Stelle TÜV NORD CERT GmbH, 0044 hat eine EG-Baumusterprüfung durchgeführt und folgende Bescheinigung ausgestellt
The notified body TÜV NORD CERT GmbH, 0044 performed a EC-type examination and issued the certificate
L'organisme notifié TÜV NORD CERT GmbH, 0044 a effectué examen CE de type et a établi l'attestation

UM-... Ex

TÜV 07 ATEX 345770

Hamburg, 20.04.2016

Ort, Datum / Place, Date / Lieu, Date

Geschäftsführer / Managing Director / Gérant: René Albrecht

Seite / Page / Page 1/1

Translation

(1) **EC-Type Examination Certificate**

TÜV NORD

(2) Equipment and protective systems intended for use in potentially explosive atmospheres, **Directive 94/9/EC**



(3) **Certificate Number** TÜV 07 ATEX 345770

(4) for the equipment: Measurement analysis system type UM-... Ex

(5) of the manufacturer: FAFNIR GmbH

(6) Address: Bahrenfelder Str. 19
22765 Hamburg
Germany

Order number: 8000345770

Date of issue: 2007-02-26

- (7) This equipment or protective system and any acceptable variation thereto are specified in the schedule to this certificate and the documents therein referred to.
- (8) The TÜV NORD CERT GmbH, notified body No. 0044 in accordance with Article 9 of the Council Directive of the EC of March 23, 1994 (94/9/EC), certifies that this equipment or protective system has been found to comply with the Essential Health and Safety Requirements relating to the design and construction of equipment and protective systems intended for use in potentially explosive atmospheres given in Annex II to the Directive. The examination and test results are recorded in the confidential report No. 07203345770.
- (9) Compliance with the Essential Health and Safety Requirements has been assured by compliance with:
- EN 50 014:1997 +A1+A2 EN 50 020:2002**
- (10) If the sign "X" is placed after the certificate number, it indicates that the equipment or protective system is subject to special conditions for safe use specified in the schedule to this certificate.
- (11) This EC-type examination certificate relates only to the design, examination and tests of the specified equipment in accordance to the Directive 94/9/EC. Further requirements of the Directive apply to the manufacturing process and supply of this equipment. These are not covered by this certificate.
- (12) The marking of the equipment or protective system must include the following:

II (1) G [Ex ia] IIC/IIB

TÜV NORD CERT GmbH, Langemarckstraße 20, 45141 Essen, accredited by the central office of the countries for safety engineering (ZLS), Ident. Nr. 0044, legal successor of the TÜV NORD CERT GmbH & Co. KG Ident. Nr. 0032

The head of the certification body

Schwedt

Hanover office, Am TÜV 1, 30519 Hanover, Fon +49 (0)511 986 1455, Fax +49 (0)511 986 1590

This certificate may only be reproduced without any change, schedule included.
Excerpts or changes shall be allowed by the TÜV NORD CERT GmbH

(13) **SCHEDULE**

(14) **EC-Type Examination Certificate No. TÜV 07 ATEX 345770**

(15) Description of equipment

The measurement analysis system UM-... Ex is used for the supply, display and limit value indication of level sensors equipped with a 4 to 20 mA interface.

The permissible ambient temperature range is 0 °C to +50 °C.

Electrical data

Auxiliary power circuit
(terminals 20, 21 and 22)

U = 230 V AC, ± 10 %, 50...60 Hz, approx. 7.5 VA or
U = 24 V AC, ± 10 %, 50...60 Hz, approx. 7.5 VA or
U = 24 V DC, ± 20 %, approx. 4.7 W
U_m = 253 V

Sensor circuit
(terminals 1 and 2)

in type of protection "intrinsic safety" EEx ia IIC
or EEx ia IIB

Maximum values: U_o = 28.4 V
I_o = 99.5 mA
R = 285 Ω
P_o = 705 mW

Characteristic: linear

C_i negligibly small
L_i negligibly small

The permissible maximum values for the outer inductance (L_o) and capacitance (C_o) must be looked up in the following table:

	EEx ia IIC		EEx ia IIB	
L _o	0.68 mH	0.2 mH	2 mH	0.2 mH
C _o	59 nF	83 nF	290 nF	570 nF

Output circuit
(terminals 3 to 17)

U ≤ 250 V, I ≤ 5 A, P ≤ 500 VA, cos φ ≥ 0.7 or
U ≤ 250 V, I ≤ 0.25 A, P ≤ 50 W

The sensor circuit is safely galvanically separated from the auxiliary power circuit and output circuit up to an apex value of the voltage of 375 V.

(16) Test documents are listed in the test report No. 07203345770.

(17) Special conditions for safe use

none

(18) Essential Health and Safety Requirements

no additional ones

Translation
1. SUPPLEMENT

to Certificate No. TÜV 07 ATEX 345770

Equipment: Measurement analysis system type UM-... Ex

Manufacturer: FAFNIR GmbH

Address: Bahrenfelder Straße 19
22765 Hamburg
Germany

Order number: 8000401623

Date of issue: 2012-01-12

Amendments:

In the future, the Measurement analysis system type UM-... Ex may also be manufactured according to the test documents listed in the test report. The modifications refer to the layout of the item.

The permissible ambient temperature range will be -20 °C to +50 °C in the future.

Furthermore the "Electrical data" was changed.

Electrical Data

Auxiliary power circuit
(terminal 20, 21 und 22)

U = 24/115/230 V a.c., $\pm 10 \%$, 50...60 Hz, about 7.5 VA
U = 24 V d.c., $\pm 20 \%$, about 4.7 W
 $U_m = 33 \text{ V}$ at 24 V d.c. resp. 24 V a.c.
 $U_m = 130 \text{ V}$ at 115 V a.c.
 $U_m = 253 \text{ V}$ at 230 V a.c.

Sensor circuit
(terminal 1 und 2)

in type of protection "Intrinsic Safety" Ex ia IIC
resp. Ex ia IIB

Maximum values: $U_o = 28.4 \text{ V}$
 $I_o = 99.5 \text{ mA}$
 $R = 285 \ \Omega$
 $P_o = 705 \text{ mW}$

Characteristic line: linear

C_i negligibly small
 L_i negligibly small

The maximum permissible value pairs of the external inductances (L_o) and capacitances (C_o) have to be taken from the following table:

1. Supplement to Certificate No. TÜV 07 ATEX 345770

	Ex ia IIC		Ex ia IIB	
L_o	0.68 mH	0.5 mH	5 mH	2 mH
C_o	59 nF	67 nF	240 nF	290 nF

Aforementioned maximum values are valid at coincidental appearance of concentrated capacitance and inductance.

Output circuit
(terminal 3 bis 17)

$U \leq 250 \text{ V}$, $I \leq 5 \text{ A}$, $P \leq 100 \text{ VA}$, $\cos \varphi \geq 0.7$ resp.
 $U \leq 250 \text{ V}$, $I \leq 0,25 \text{ A}$, $P \leq 50 \text{ W}$

The sensor circuit is safely galvanically separated from auxiliary power circuit and output circuit up to a peak crest value of the voltage of 375 V.

Furthermore the equipment was evaluated according to the standards EN 60079-0:2009, EN 60079-11:2007 and EN 60079-26:2007.

All other data apply unchanged for this supplement.

The device will then be labeled as follows:

 II (1) G [Ex ia Ga] IIC

The equipment incl. of this supplement meets the requirements of these standards:

EN 60079-0:2009

EN 60079-11:2007

EN 60079-26:2007

(16) Test documents are listed in the test report No. 11 203 091922.

(17) Special conditions for safe use

none

1. Supplement to Certificate No. TÜV 07 ATEX 345770

(18) Essential Health and Safety Requirements

no additional ones

TÜV NORD CERT GmbH, Langemarckstraße 20, 45141 Essen, notified by the central office of the countries for safety engineering (ZLS), Ident. Nr. 0044, legal successor of the TÜV NORD CERT GmbH & Co. KG Ident. Nr. 0032

The head of the notified body

A handwritten signature in blue ink, appearing to read "Schwedt".

Schwedt

Hanover office, Am TÜV 1, 30519 Hannover, Fon +49 (0)511 986 1455, Fax +49 (0)511 986 1590

Instructions

Measurement evaluation unit type UM-... Ex

I Range of application

The measurement evaluation unit type UM-... Ex can serve as part of an overfilling prevention system.

II Standards

See EC-type examination certificate including supplements.

III Instructions for safe ...

III.a ... use

The measurement evaluation unit serves as associated equipment and is not approved for use inside potentially explosive atmospheres. The intrinsically safe sensor circuit of the measurement evaluation unit can be lead in zone 0 and is suitable for all gas groups (IIA, IIB and IIC).

The approval is valid only for the versions of the device

UM-Ex

UM-O Ex

III.b ... assembling and dismantling

The measurement evaluation unit is suitable for wall mounting. The evaluation unit must be installed outside potentially explosive atmospheres.

III.c ... installation

Wiring work may only be performed with the power disconnected. The special EN regulations including EN 60079-14 and local installation regulations must be observed.

The wiring from the sensor (for example TORRIX Ex ...) to the measurement evaluation unit (preferably blue coloured cable) may not exceed the permissible inductance and capacitance according to section V.

Terminal designation:

Power supply circuit:	L, N and PE (22, 21 and 20)
Acknowledge circuit:	Ack. (19 and 18)
Outputs:	Relay 5 (17, 16 and 15) Relay 4 (14, 13 and 12) Relay 3 (11, 10 and 9) Relay 2 (8, 7 and 6) Relay 1 (5, 4 and 3)
Sensor circuit:	- + Probe 4..20 mA (2 and 1)

III.d ... putting into service

Before putting into service, all devices must be checked to ensure they are properly connected and installed. The power supply, also of connected equipment, must be checked.

III.e ... maintenance (servicing and emergency repair)

In general, the measurement evaluation unit is maintenance-free. In case of a defect it must be send back to FAFNIR or one of its representations.

IV Equipment marking

1	Manufacturer:	FAFNIR GmbH, Hamburg				
2	Type designation:	UM-... Ex				
3	Certificate number:	TÜV 07 ATEX 345770				
4	Ex marking::	Ⓔ II (1) G [Ex ia Ga] IIC				
5	CE marking:	CE 0044				
6	Technical data:	$T_a \leq +50 \text{ °C}$ $U_o \leq 28.4 \text{ V}$ $I_o \leq 99.5 \text{ mA}$ $P_o \leq 705 \text{ mW}$				
			IIC		IIB	
		$L_o \leq$	680 μH	500 μH	5 mH	2 mH
		$C_o \leq$	59 nF	67 nF	240 nF	290 nF

V Technical data

The power supply for the evaluation unit, depending on model

- U = 24 V DC \pm 20 %, ~4,7 W, or
- U = 24 V AC \pm 10 %, 50 ... 60 Hz, ~7,5 VA, or
- U = 115 V AC \pm 10 %, 50 ... 60 Hz, ~7,5 VA, or
- U = 230 V AC \pm 10 %, 50 ... 60 Hz, ~7,5 VA.

The maximum safety voltage is

- $U_m = 33 \text{ V}$ at 24 V AC/DC, resp.
- $U_m = 130 \text{ V}$ at 115 V AC, resp.
- $U_m = 253 \text{ V}$ at 230 V AC.

The electric circuit of the sensor is designed with "Intrinsic safety" (ia) ignition protection class with a linear output characteristic. Output values per electric circuit are

Output voltage	$U_o \leq 28.4 \text{ V}$
Output current	$I_o \leq 99.5 \text{ mA}$
Output power	$P_o \leq 705 \text{ mW}$
Internal capacitance	C_i negligibly small
Internal inductance	L_i negligibly small
Permissible external	IIC
inductance	IIB
	$L_o \leq$
	680 μH
	500 μH
	5 mH
	2 mH
capacitance	$C_o \leq$
	59 nF
	67 nF
	240 nF
	290 nF

The intrinsically safe sensor circuits are galvanically isolated from the supply circuit safely up to a peak crest voltage of 375 V.

As outputs five relays are available each with potential-free relay contacts. The terminal values are:

- Alternating current AC $U \leq 250 \text{ V}; I \leq 5 \text{ A}; P \leq 100 \text{ VA}; \cos \varphi \geq 0.7$
- Direct current DC $U \leq 250 \text{ V}; I \leq 250 \text{ mA}; P \leq 50 \text{ W}$

When an acknowledge button is used it must be potential-free, as the connectors are wired-up to the power supply!

The evaluation unit can be used in the following ambient temperature range:

$$T_a = -20 \text{ °C} \dots +50 \text{ °C}$$



FAFNIR GmbH
Schnackenburgallee 149c
22525 Hamburg, Germany
T: +49/40/39 82 07 - 0
F: +49/40/390 63 39
E-mail: info@fafnir.com
Web: www.fafnir.com
