

SEPARIX

SEPARIX-Control CT,
SEPARIX-C L Plus and SEPARIX-T L Plus

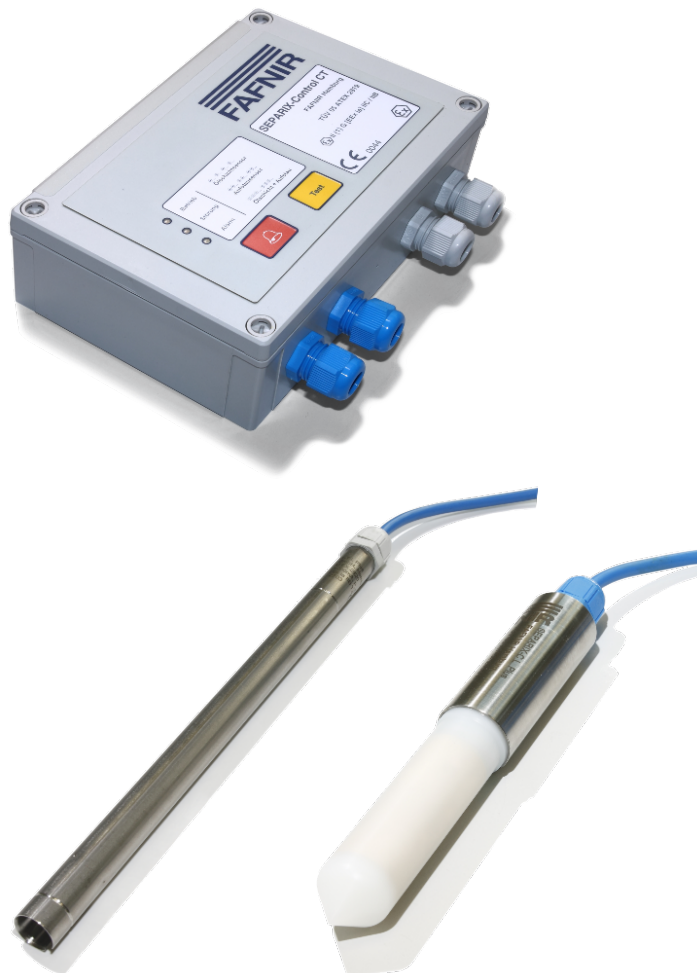

Edition: 2019-01
Version: 6
Art. no.: 207105

Table of contents

1	Properties of the SEPARIX system	1
2	Safety instructions	1
3	The SEPARIX sensors	3
3.1	Design and function	3
3.1.1	... of the interface sensor SEPARIX-C L Plus.....	3
3.1.2	... of the high-level sensor SEPARIX-T L Plus.....	4
3.2	Installation	5
3.2.1	... of the interface sensor SEPARIX-C L Plus.....	5
3.2.2	... of the high-level sensor SEPARIX-T L Plus.....	7
3.3	Maintenance and cleaning	9
3.3.1	... of the interface sensor SEPARIX-C L Plus.....	9
3.3.2	... of the high-level sensor SEPARIX-T L Plus.....	9
3.4	Technical Data	10
4	SEPARIX-Control CT measuring transducer	11
4.1	Design and function	11
4.1.1	LEDs.....	12
4.1.2	Buzzer	12
4.1.3	Membrane buttons.....	12
4.2	Configuration.....	13
4.2.1	Activation of SEPARIX-C	14
4.2.2	Activation of SEPARIX-T	14
4.2.3	Relay energised.....	14
4.2.4	Relay acknowledgeable.....	14
4.2.5	Alarm delay.....	15
4.2.6	Acknowledge button.....	15
4.2.7	Test button	15
4.2.8	Alarm buzzer	15
4.3	Commissioning.....	15
4.4	Faults and alarms.....	17

4.4.1	Overview of fault and alarm causes	17
4.4.2	Acknowledgement of faults or alarms	17
4.5	Technical data	18
5	Function test.....	19
6	List of figures.....	20
7	List of tables.....	20
8	Annex.....	21
8.1	SEPARIX-C	21
8.1.1	EC – Declaration of Conformity	21
8.1.2	EU-Type Examination Certificate	22
8.1.3	Instructions interface sensor SEPARIX-C	24
8.2	SEPARIX-T	26
8.2.1	EC – Declaration of Conformity	26
8.2.2	EC-Type Examination Certificate	27
8.2.3	Instructions high-level sensor SEPARIX-T	30
8.3	SEPARIX-Control CT	33
8.3.1	EC-Type Examination Certificate	33
8.3.2	Instructions measuring transducer SEPARIX-Control CT.....	36

© Copyright:

Reproduction and translation are permitted only with the written consent of the FAFNIR GmbH. The FAFNIR GmbH reserves the right to make product alterations without prior notice.

1 Properties of the SEPARIX system

The SEPARIX system is a warning system that, depending on the version, is able to monitor both the thickness of the oil or light liquid layer in a light liquid separator as well as the level of this fluid. The system consists of the following components:

- Interface sensor SEPARIX-C L Plus
- High-level sensor SEPARIX-T L Plus
- SEPARIX-Control CT measuring transducer

The measuring transducer serves as power supply and signal processing of the sensors.

The sensors transmit a signal to the connected measuring transducer whenever the oil / light liquid layer exceeds a defined thickness (interface sensor) or whenever the liquid level in the separator rises above an impermissible threshold (high-level sensor). The measuring transducer then generates alarms so that appropriate measures can be taken to stop contaminants from being discharged into the sewage system.

Faults and alarms are signalled visually by LEDs and audibly by a buzzer. The measuring transducer also supports the connection of external alarm transmitters.

2 Safety instructions

SEPARIX serves for monitoring the light liquid layer and/or the liquid level in light liquid separators. Use the system exclusively for this purpose. The manufacturer accepts no liability for any form of damage resulting from improper use.

The interface sensors, high-level sensors and measuring transducers have been developed, manufactured and tested in accordance with the latest good engineering practices and generally accepted safety standards. Nevertheless, hazards may arise from their use. For this reason, the following safety instructions must be observed:

- Do not change or modify the system or add any equipment without the prior consent of the manufacturer.
- The installation and maintenance of the measuring transducer and the sensors must be carried out only by expert personnel. Specialised knowledge must be acquired by regular training.
- All installation and maintenance work, with the exception of functional testing, must be carried out with the power disconnected.
- Installers and service technicians must comply with all applicable safety regulations. This also applies to any local safety and accident prevention regulations which are not stated in this user guide.

- The sensors are suitable for installation in Ex Zone 0. Observe all applicable rules and regulations for potentially explosive atmospheres.
- The measuring transducer must be installed outside the Ex Zone.
- The warning system must be tested at the intervals specified by local regulations.
- To avoid the risk of electrostatic charge, the SEPARIX-C L Plus interface sensors are not permitted to be used in heavy-flowing, non-conducting fluids (e.g. in pipework or stirred tanks).
- Also for cleaning the SEPARIX-C L Plus interface sensors the risk of electrostatic charge must be prevented by the using damp cloths.
- The SEPARIX-C L Plus interface sensor and the SEPARIX-T L Plus high-level sensor are not permitted to be used in aggressive media.

The safety instructions in this user guide are marked as follows:



If these safety instructions are not observed, it may result in the risk of accident or damage to the SEPARIX system.



Useful tips and information in this user guide you should observe, appear in italics and are identified by this symbol.

3 The SEPARIX sensors

3.1 Design and function ...

3.1.1 ... of the interface sensor SEPARIX-C L Plus

The SEPARIX-C L Plus interface sensors, in conjunction with the SEPARIX-Control CT measuring transducer, form an automatic warning device for light liquid separators. The warning system responds to a change in the thickness of the oil / light liquid layer. It generates an alarm signal before the automatic closure device shuts off the outlet of the separator due to a high oil / light liquid level.



The SEPARIX-C L Plus is not permitted to be used in aggressive media.

The sensor works according to the capacitive measuring principle: To detect the interface, it uses the difference between the relative dielectric constant of water and of light liquids, e.g. oil. The measurement on the SEPARIX-C L Plus is made over the entire surface of the

6 cm long measuring range. This helps to achieve significant insensitivity to contaminations that could otherwise trigger false alarms.

The typical switch point is approximately 40 mm above the sensor tip. Depending on the degree of contamination, it may shift 10–20 mm upwards (within the safe zone). In the event of heavy contamination, which, due to the nature of operation, cannot always be avoided even with regular maintenance, no false alarm is triggered (without the presence of a light liquid layer). Instead, the alarm is triggered at a slightly reduced layer thickness.

The SEPARIX-Control CT measuring transducer powers the sensors and evaluates the sensor signals.

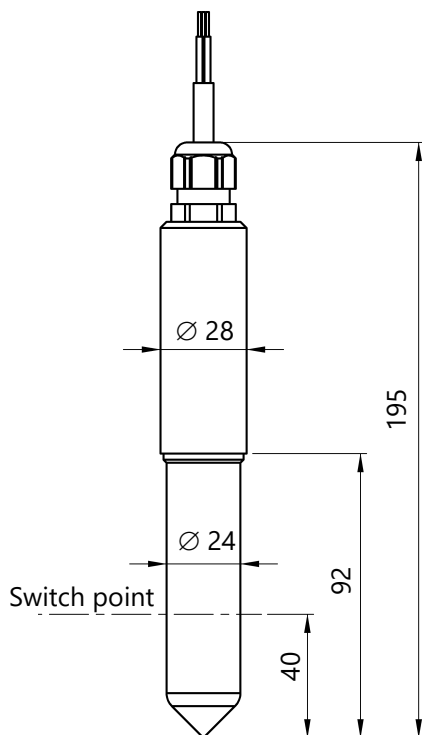

Figure 1: SEPARIX-C L Plus, dimensions

3.1.2 ... of the high-level sensor SEPARIX-T L Plus

The SEPARIX-C L Plus high-level sensor, in conjunction with the SEPARIX-Control CT measuring transducer, forms an automatic warning device for light liquid separators. The warning system responds to the level of liquid in the separator (whether oil, light liquid or water). It generates an alarm signal whenever the liquid level in the separator rises above an impermissible threshold, e.g. due to reverse flow from the separator outlet, or because the automatic closure device has shut off the outlet of the separator due to a high oil / light liquid layer.



The SEPARIX-T L Plus is not permitted to be used in aggressive media.

The sensors work without moving parts according to the thermal measuring principle, based on the different thermal conductivity of gases and liquids:

A PTC resistor in the sensor tip is heated up by the measuring transducer, which increases the resistance of the PTC resistor if surrounded by gas (e.g. air). As soon as the sensor tip

comes into contact with liquid, the resistance of the PTC resistor drops because liquids have a significantly higher thermal conductivity than gases and therefore cool the sensor down. The measuring transducer detects this change in resistance whether it is caused by light liquid or water and triggers an alarm.

To avoid damage and disturbances caused by splash water, the sensor tip is protected by the sensor housing, which is slotted and open at the bottom end. The switch point is 35 mm above the lower edge of the sensor housing and is marked by a circular groove on the sensor housing.

The SEPARIX-Control CT measuring transducer powers the sensors and evaluates the sensor signals.



After turning on the SEPARIX-Control CT, the high-level sensor must heat up first before it is ready for operation. According to the ambient temperature this heating phase can last up to 2 minutes.

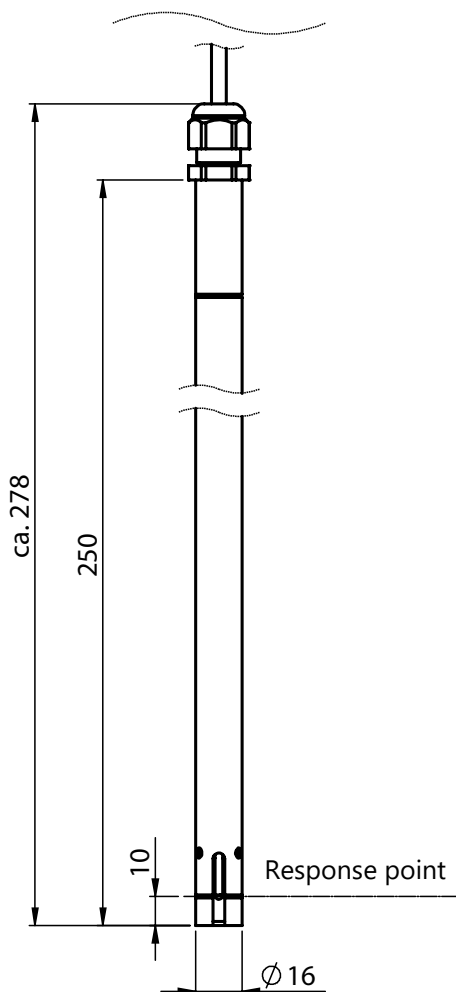

Figure 2: SEPARIX-T L Plus, dimensions

3.2 Installation ...



For sensor installation observe the following safety instructions:

- The installation must be carried out only by expert personnel and in accordance with all applicable safety regulations. This also applies to any local safety and accident prevention regulations which are not stated in this user guide.
- The sensors are suitable for installation in Ex Zone 0. Observe all applicable rules and regulations for potentially explosive atmospheres (VDE in Germany respectively national installation rules and regulations).
- For installing, the sensors must be disconnected from power supply.
-

3.2.1 ... of the interface sensor SEPARIX-C L Plus



To avoid the risk of electrostatic charge, the sensors are not permitted to be used in heavy-flowing, non-conducting fluids (e.g. in pipework or stirred tanks). The SEPARIX-C L Plus is not permitted to be used in aggressive media.

The interface sensor (4) is suspended on its cable (7) in the light liquid separator (3), immersed into the fluid to be monitored and in a distance of minimum 100 mm to the separator wall and all separator internal installations (see Figure 3). It should be observed not to install the sensor directly near the separator's inlet because of an increased risk of contamination or disturbance by splashing fluids. The correct fastening method and materials depend on local installation rules and regulations and the material used for the separator (concrete, plastic, metal, etc.).

The interface sensor must be installed in such a way that the switch point (5) is undercut at the maximum permissible layer thickness (6). For example, if a light liquid layer of 300 mm or more is to be detected, the switch point of the sensor must be 300 mm below the surface of the fluid.

As an adjustment aid, the connection cable can be marked at the appropriate height, e.g. with a cable tie:

- (1) From the sensor tip, measure 40 mm (switch point) plus the layer thickness and fasten the cable tie to the connection cable as a marking (for example above: $40\text{ mm} + 300\text{ mm} = 340\text{ mm}$ above the sensor tip).
- (2) Install the interface sensor so that the marking is at the level of the liquid surface.

 *In separators with an automatic closure device, the SEPARIX-C L Plus must be installed at a height above the closure device appropriate to the dimensions and operating conditions of the separator so that the system operator still has enough time to take the necessary measures in the event of an alarm.*

The interface sensor is equipped with a non-detachable blue cable (7) (3 x 0.5 mm²) (SEPARIX-C L Plus: 5 m long). This cable can be shortened or extended up to 250 m with the use of a junction box (1) suitable for the environmental conditions concerned and an extension cable (2).

 *If used in a potentially explosive atmosphere, the extension cable must not exceed the maximum permissible capacitance and inductance of the measuring transducer (see section 4.5). To avoid disturbances or damage to the sensor or measuring transducer, the selected junction box must offer sufficient protection against the ingress of moisture or fluid in the environmental and operating conditions in which it is used.*

 *For connecting the sensor to the measuring transducer, please observe the installation instructions for SEPARIX-Control CT in this or another user guide for compatible FAFNIR measuring transducers.*

 The correct operation of the sensors is guaranteed only in conjunction with a compatible and approved measuring transducer.

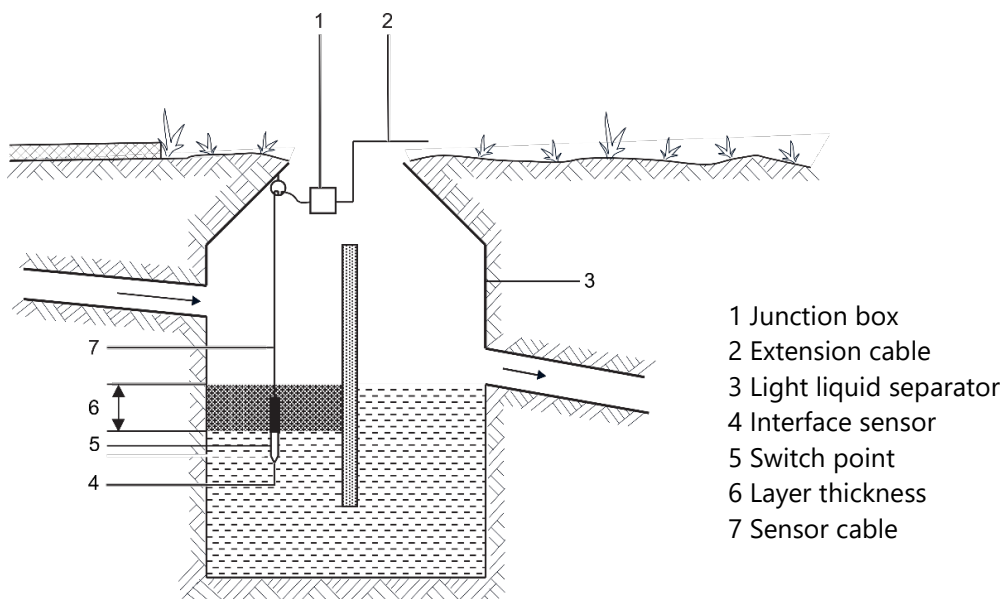

Figure 3: SEPARIX-C, installation

3.2.2 ... of the high-level sensor SEPARIX-T L Plus



The SEPARIX-T L Plus is not permitted to be used in aggressive media.

The high-level sensor is suspended on its cable (6) in the light liquid separator (3) in distance to the inlet because there is an increased risk of contamination or disturbance by splashing fluids (see Figure 4: SEPARIX-T, installation). The correct fastening method and materials depend on local installation rules and regulations and the material used for the separator (concrete, plastic, metal, etc.).

The measuring transducer detects when the sensor tip of the connected high-level sensor (5) is immersed into fluid (whether light liquid or water). This response point (4) is marked on the outside of the sensor by a circular groove. The high-level sensor must be installed in such a way that the response point (4) is at the height above which an alarm is to be triggered by a rising liquid level.

The high-level sensor is equipped with an undetachable blue cable (6) (2 x 0.5 mm²) with a length of 5 m. This cable can be shortened or extended up to 250 m with the use of a junction box (1) suitable for the environmental conditions concerned and an extension cable (2).

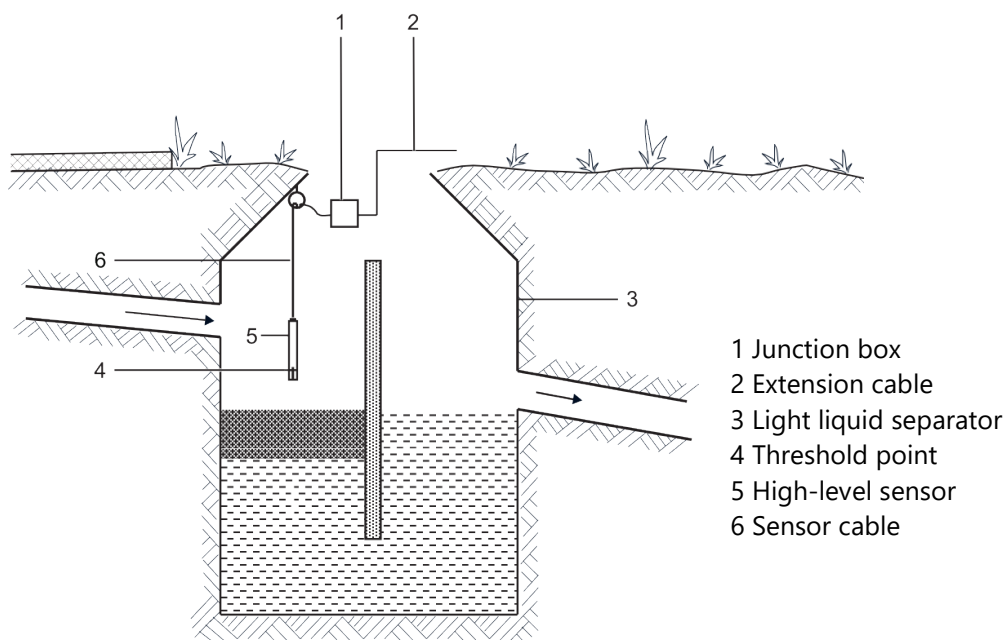

Figure 4: SEPARIX-T, installation



If used in a potentially explosive atmosphere, the extension cable must not exceed the maximum permissible capacitance and inductance of the measuring transducer (see section 4.5). To avoid disturbances or damage to the sensor or measuring transducer, the selected junction box must offer sufficient protection against the ingress of moisture or fluid in the environmental and operating conditions in which it is used.



For connecting the sensor to the measuring transducer, please observe the installation instructions for SEPARIX-Control CT in this or another user guide for compatible FAFNIR measuring transducers.



The correct operation of the sensors is guaranteed only in conjunction with a compatible and approved measuring transducer.

3.3 Maintenance and cleaning ...



For sensor maintenance observe the following safety information:

- The maintenance must be carried out only by expert personnel and in compliance with all applicable safety regulations. This also applies to any local safety and accident prevention regulations which are not stated in this user guide.
- The sensors are suitable for installation in Ex Zone 0.
Observe all applicable rules and regulations for potentially explosive atmospheres (VDE in Germany respectively national installation rules and regulations).
- For servicing, the sensors must be disconnected from power supply.
- To avoid the risk of electrostatic charge, always use a damp cloth to clean the SEPARIX-C L Plus interface sensors.

As the sensor has no moving parts, no special maintenance is required.

The sensor needs only to be cleaned routinely as part of regular maintenance, cleaning and clearance work on the separator.

3.3.1 ... of the interface sensor SEPARIX-C L Plus

Clean the sensor with a damp cloth to minimise the effects of contaminants that could trigger a false alarm (see section 3.1). Grease-dissolving cleaning agents can be used for heavy contamination.

It is recommended to test the sensor whenever it has been cleaned (see section 5).

3.3.2 ... of the high-level sensor SEPARIX-T L Plus

Check the sensor routinely for contamination as part of maintenance work on the separator and after an alarm, and, if necessary, clean it to prevent faulty operation.

After an alarm, the sensor tip in particular should be inspected for contamination. If the sensor tip is encrusted with dirt, this can be cleaned away using a soft brush and a grease-dissolving cleaning agent.



Do not use sharp-edged objects to clean the sensor tip under any circumstances.

It is recommended to test the sensor whenever it has been cleaned (see section 5).

3.4 Technical Data

Interface sensors	SEPARIX-C L Plus
Ex marking:	II 1 G Ex ia IIB T4 Ga
Certificate	TÜV 03 ATEX 2368 X
Protection class	IP68
Dimensions	28 mm x 195 mm
Cable length	5.0 m
Ambient temperature	-20 °C ... +70 °C -20 °C ... +60 °C (explosion-risk area)
Medium temperature	0 °C ... +70 °C 0 °C ... +60 °C (explosion-risk area)
Connection data Voltage: Current: Power: Capacitance (externally effective): Inductance (externally effective):	$U_i \leq 15 \text{ V}$ $I_i \leq 30 \text{ mA}$ $P_i \leq 100 \text{ mW}$ $C_i \leq 10 \text{ nF}$ $L_i \leq 100 \text{ } \mu\text{H}$

High-level sensors	SEPARIX-T L Plus
Ex marking:	II 1 G Ex ia IIC T4 Ga II 1/2 G Ex ia IIC T4 Ga/Gb
Certificate	TÜV 00 ATEX 1656 X
Protection class	IP68
Dimensions	16 mm x 278 mm
Cable length	5 m
Ambient temperature	-25°C ... +60 °C
Medium temperature	-25°C ... +50 °C
Connection data Voltage: Current: Power: Capacitance (externally effective): Inductance (externally effective):	$U_i \leq 30 \text{ V}$ $I_i \leq 200 \text{ mA}$ $P_i \leq 1 \text{ W}$ C_i negligibly small L_i negligibly small

4 SEPARIX-Control CT measuring transducer

4.1 Design and function

The SEPARIX-Control CT measuring transducer serves as power supply and signal processing of the connected SEPARIX-C L Plus interface sensor and/or the SEPARIX-T L Plus high-level sensor and together with the sensors forms a warning system for light liquid separators.

With the interface sensor, the warning system reacts to the thickness of the oil / light liquid layer. It generates an alarm signal before the automatic closure device shuts off the outlet of the separator due to a high oil / light liquid level.

With the high-level sensor, the warning system reacts to the fluid height (whether oil, light fluid or water) in the separator. It generates an alarm signal whenever the liquid level in the separator rises above an impermissible threshold, e.g. due to reverse flow of the separator outlet, or because the automatic closure device has shut off the outlet of the separator due to a high oil / light liquid layer.

The two connectable sensors can individually be activated or deactivated in the SEPARIX-Control CT.

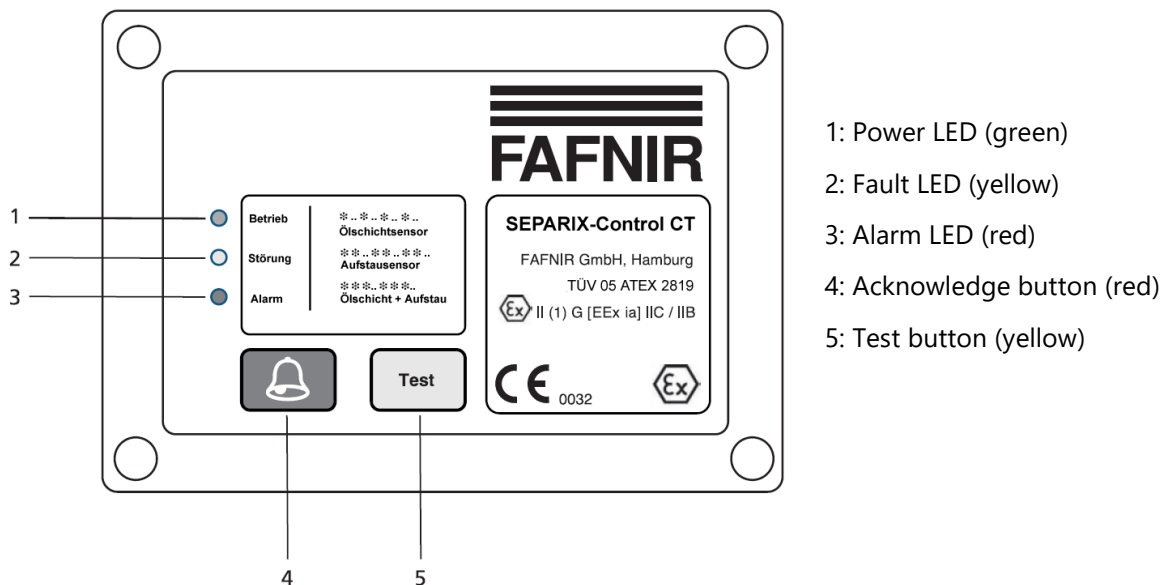

Figure 5: SEPARIX-Control CT, top view

Faults and alarms are signalled visually by LEDs (1-3) and audibly by a buzzer. Two potential-free changeover contacts permit the connection of external alarm transmitters and are switched in the event of an alarm.

Two membrane buttons (4/5) are used to acknowledge faults and alarms as well as to test the alarm signalling behaviour of the device and, where applicable, connected alarm transmitters. The alarm signalling of the device can be configured individually using the "Options" DIP switch (see section 4.2).

4.1.1 LEDs

The SEPARIX-Control CT measuring transducer is equipped with three LEDs (see Figure 5). The measuring transducer lamps show different operating states and/or faults:

Power LED (green)	Fault LED (yellow)	Alarm LED (red)
<ul style="list-style-type: none"> blinks repeatedly 1x short if only the interface sensor is activated. blinks repeatedly 2x short if only the high-level sensor is activated. blinks repeatedly 3x short if both sensors are activated. OFF, whenever both sensors are deactivated or the device is out of operation. 	<ul style="list-style-type: none"> blinks repeatedly 1x short if there is a fault with the interface sensor. blinks repeatedly 2x short if there is a fault with the high-level sensor. blinks repeatedly 3x short if there is fault with the interface sensor and the high-level sensor. 	<ul style="list-style-type: none"> blinks repeatedly 1x short if the interface sensor signals an alarm (max. layer thickness reached/exceeded). blinks repeatedly 2x short if the high-level sensor signals an alarm (liquid level too high). blinks repeatedly 3x short if both sensors signal an alarm. OFF, when the cause of the alarm has been rectified.



Possible causes: cable break, short circuit, sensor signal outside the permissible range, sensor not working, defect in the sensor evaluation of the measuring transducer, high-level sensor tip encrusted with dirt.

4.1.2 Buzzer



The measuring transducer is equipped with a buzzer that produces an audible signal in the event of a fault or alarm.

The acoustic signal will be turned off after pressing the acknowledge button. If desired, the measuring transducer configuration settings allow to deactivate the buzzer so that it no longer sounds (see section 4.2).

4.1.3 Membrane buttons

The measuring transducer has two membrane buttons:



- The red acknowledge button (4) confirms faults and alarms signalled by the LEDs and the buzzer (also in test mode). Pressing the button switches OFF the buzzer and the relay output returns to the normal operating state. The LEDs continue to signal the fault or alarm condition.
- Pressing the yellow test button (5) triggers a simulated alarm to proceed a system test (function of the internal alarm system, the relay outputs and, where applicable, the connected external alarm transmitters).

-  A system test is only possible if the SEPARIX-T L Plus high-level sensor has been heated up.
-  If the test button is pressed alone, an unacknowledged alarm will be simulated. If both the test and acknowledge buttons are pressed simultaneously, an acknowledged alarm will be simulated.
-  The test button does not replace the function test of the warning system (see section 5).

The measuring transducer configuration settings allow both buttons to be locked, e.g. in cases where the measuring transducer is part of a central control system and the system operator shall not acknowledge any faults or carry out any tests (see section 4.2).

4.2 Configuration

The measuring transducer is factory preconfigured and ready for operation. With the help of the "Options" DIP switch you are able to configure SEPARIX-Control CT (see following table):

	Option	DIP switch OFF 	DIP switch ON 
1	SEPARIX-C ...	OFF	ON *
2	SEPARIX-T ...	OFF	ON *
3	Relay energised	Alarm *	No alarm
4	Relay acknowledgeable	Yes *	No
5	Alarm delay	60 sec. *	No
6	Acknowledge button	Locked	Unlocked *
7	Test button	Locked	Unlocked *
8	Alarm buzzer	Locked	Unlocked *

* : Default factory setting

Table 1: SEPARIX-Control CT, configuration

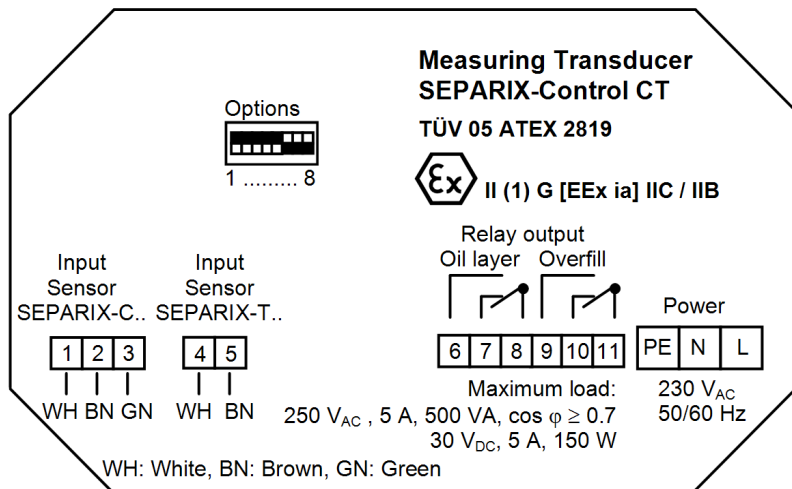



Figure 6: SEPARIX-Control CT, terminals and "Options" DIP switch

4.2.1 Activation of SEPARIX-C

With switch 1, the SEPARIX-C L Plus interface sensor is activated. The Power LED indicates whether the sensor is activated or deactivated (see section 4.1.1). The sensor is activated by default.

 Whenever both sensors will be deactivated, the device is no longer operational and the Power LED (see Figure 5) is OFF.

4.2.2 Activation of SEPARIX-T

With switch 2, the SEPARIX-T L Plus high-level sensor is activated. The Power LED indicates whether the sensor is activated or deactivated (see section 4.1.1). The sensor is activated by default.

 Whenever both sensors will be deactivated, the device is no longer operational and the Power LED (see Figure 5) is OFF.

4.2.3 Relay energised

With switch 3, it is configured whether the relay is energised in case of a fault/alarm or if it is energised in normal operation. By factory default the relay is set energised in case of a fault/alarm.

4.2.4 Relay acknowledgeable

With switch 4 the relay is configured whether it can be acknowledged and reset in case of a fault/alarm with the red acknowledge button. Otherwise, the relay is reset only, if the cause of the fault/alarm is corrected. By factory default the relay is set acknowledgeable.

4.2.5 Alarm delay

With switch 5, the alarm delay is configured. By factory default the alarm delay is activated (60 seconds). A fault or alarm is triggered only if the cause of the fault/alarm is present for at least 60 seconds. The same applies to the switching off of fault or an alarm: they switch off 60 seconds after the cause of the fault or alarm has been corrected. The alarm delay is intended to prevent false alarms, which e.g. could occur by waves or splash water in the separator. The alarm delay can be deactivated, e.g. for demonstration purposes. For normal operation, however, it is strongly recommended to have the alarm delay activated in order to prevent false alarms.

4.2.6 Acknowledge button

With switch 6, the red acknowledge button is configured. By factory default the acknowledge button is set enabled, so that the fault or alarm can be acknowledged by the system operator. The button can be locked if an acknowledgement by the system operator is not required. In this case, the unacknowledged state will persist until the cause of the fault or alarm has been corrected.

4.2.7 Test button

With switch 7, the test button is configured. By factory default the yellow test button is set enabled so that an alarm can be simulated and any connected external alarm transmitters can be tested. If this test mode capability is not required for the system operator, it is possible to lock the button.

4.2.8 Alarm buzzer

With switch 8, the alarm buzzer is configured. By factory default the internal alarm buzzer is set enabled so that an audible signal is given for faults and alarms. If an audible signal is not required, it is possible to disable the buzzer.

4.3 Commissioning



Observe the following safety information for commissioning of the measuring transducer:

- The installation must be carried out only by expert personnel and in accordance with all applicable safety regulations. This also applies to any local safety and accident prevention regulations which are not stated in this user guide.
- The measuring transducer must not be installed within the potentially explosive atmosphere.
- The wiring must be carried out only with the power disconnected.

Install the measuring transducer in accordance with the connection diagram on the inside of the device cover.



Observe the maximum operating parameter values specified in the connection diagram (see Figure 6).

- (1) Check the configuration of the measuring transducer and correct if necessary (see section 4.2).
- (2) Whichever applicable, connect the SEPARIX-C L Plus interface sensor to the measuring transducer according to the connection diagram.
- (3) Whichever applicable, connect the SEPARIX-T L Plus high-level sensor to the measuring transducer according to the connection diagram.



If a shielded cable is used, this must be earthed in accordance with national or local installation rules and regulations.

- (4) Whichever applicable, connect external alarm devices to the terminals 6 to 8 (interface relay output) and 9 to 11 (high level relay output) of the SEPARIX-Control CT measuring transducer.
- (5) Connect the measuring transducer to an auxiliary power unit of 230 V_{AC}, 50/60 Hz, using the terminals marked PE/N/L. The green "Power" LED of the SEPARIX-Control CT blinks. The warning system is operational.



The SEPARIX-Control CT measuring transducer with a connected SEPARIX-T L Plus high-level sensor is only operational after the sensor has heated up. According to the ambient temperature this heating phase can last up to 2 minutes.

- (6) Inform owner and/or system operator about the purpose of the warning system and, where applicable, of any additional alarm transmitters that have been connected. Point out all aspects specific to the present arrangement, particularly if the measuring transducer's default factory settings have been changed (e.g. acknowledge button disabled). Also instruct them how to act in the event of a fault or an alarm (e.g. acknowledge alarms and faults, customer service phone no. in the event of an alarm, etc.).

4.4 Faults and alarms

In case of a fault or an alarm the factory-set SEPARIX-Control CT triggers with the buzzer an audible alarm signal. In case of a fault, additionally the yellow fault LED blinks, and with an alarm, additionally the red alarm LED blinks.

4.4.1 Overview of fault and alarm causes

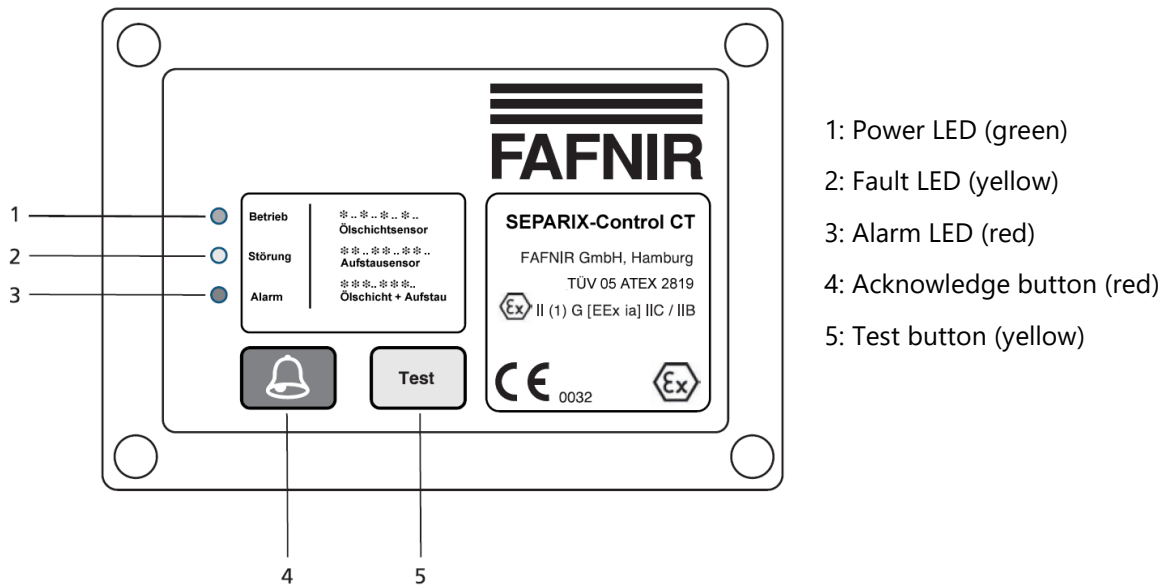

Figure 7: SEPARIX-Control CT, fault and alarm display

Blink code	Power LED (green)	Fault LED (yellow)	Alarm LED (red)
1x short	Interface sensor	Interface sensor	Oil layer
2x short	High-level sensor	High-level sensor	High level
3x short	Interface sensor and high-level sensor	Interface sensor and high-level sensor	Oil layer and high level

4.4.2 Acknowledgement of faults or alarms

- Press red acknowledge button.

The fault or alarm is acknowledged and the buzzer stops. The yellow or red LED continues to blink because the cause of the fault or alarm has not yet been corrected.



Faults and alarms are repeated every 24 hours after they have been acknowledged (red acknowledge button pressed) so that they are brought to the system operator's attention again.

- Inform the technical service responsible for the light liquid separator.

The yellow or red LED will stop blinking as soon as the cause of the fault or alarm has been corrected by the technical service.



As the configuration of the warning system may have been customised for the specific application (e.g. disable acknowledge button) or additional external alarm transmitters may have been connected, you should ask the technical service to explain how to acknowledge the faults and alarms in your particular system arrangement.

4.5 Technical data

Measuring transducer	SEPARIX-Control CT															
Explosion protection	II (1) G [Ex ia] IIC/IIB															
Certificate	TÜV 05 ATEX 2819															
Dimensions (H x W x D)	155 mm x 180 mm x 60 mm															
Protection class	IP65															
Ambient temperature	0 °C ... +40 °C															
Power supply	230 V AC \pm 10%, 50/60 Hz, \leq 8 VA															
Connection data Relay circuit	AC: $U \leq 250$ V, $I \leq 5$ A, $P \leq 500$ VA, $\cos \varphi \geq 0,7$ DC: $U \leq 250$ V, $I \leq 250$ mA, $P \leq 50$ W															
Connection data SEPARIX-C sensor circuit: Voltage: Current: Power: Internal resistance: Capacitance (externally effective): Inductance (externally effective): External capacitance: External inductance:	$U_0 \leq 14,3$ V $I_0 \leq 21,2$ mA $P_0 \leq 75,7$ mW $R_i \geq 673$ Ω $C_i \leq 1$ nF L_i negligibly small <table style="width: 100%; border: none;"> <tr> <td></td> <td style="text-align: center;">IIC</td> <td style="text-align: center;">IIB</td> </tr> <tr> <td>$C_0 \leq 680$ nF</td> <td style="text-align: center;">$4,28$ μF</td> <td></td> </tr> <tr> <td>$L_0 \leq 80$ mH</td> <td></td> <td style="text-align: center;">300 mH</td> </tr> </table>		IIC	IIB	$C_0 \leq 680$ nF	$4,28$ μ F		$L_0 \leq 80$ mH		300 mH						
	IIC	IIB														
$C_0 \leq 680$ nF	$4,28$ μ F															
$L_0 \leq 80$ mH		300 mH														
Connection data SEPARIX-T sensor circuit: Voltage: Current: Power: Internal resistance: Capacitance (externally effective): Inductance (externally effective): External capacitance: External inductance:	$U_0 \leq 15,8$ V $I_0 \leq 154$ mA $P_0 \leq 600$ mW $R_i \geq 157$ Ω $C_i \leq 0.3$ nF L_i negligibly small <table style="width: 100%; border: none;"> <tr> <td></td> <td style="text-align: center;">IIC</td> <td style="text-align: center;">IIB</td> </tr> <tr> <td>$C_0 \leq 230$ nF</td> <td style="text-align: center;">310 nF</td> <td style="text-align: center;">760 nF</td> </tr> <tr> <td>$L_0 \leq 440$ μH</td> <td style="text-align: center;">100 μH</td> <td style="text-align: center;">5 mH</td> </tr> <tr> <td></td> <td></td> <td style="text-align: center;">$1,6$ μF</td> </tr> <tr> <td></td> <td></td> <td style="text-align: center;">1 mH</td> </tr> </table>		IIC	IIB	$C_0 \leq 230$ nF	310 nF	760 nF	$L_0 \leq 440$ μ H	100 μ H	5 mH			$1,6$ μ F			1 mH
	IIC	IIB														
$C_0 \leq 230$ nF	310 nF	760 nF														
$L_0 \leq 440$ μ H	100 μ H	5 mH														
		$1,6$ μ F														
		1 mH														

5 Function test

For the function test of the SEPARIX-C L Plus interface sensors:

- (1) First remove the interface sensor from the separator liquid.
- (2) Clean the sensor (see section 3.3)
Water or watery dirt are removed ¹.
- (3) Place the sensor on a dry and non-metallic surface.
As the sensor behaves in the same way in air as in light liquid, the measuring transducer must trigger the appropriate alarm signal ³ after the adjusted alarm delay time ² set on the transducer (default setting 1 minute).
- (4) As a counter check, immerse the interface sensor in water.
After expiration of the alarm delay time ² (default setting 1 minute), the alarm signal at the measuring transducer must revert to its original state ³.

For the function test of the SEPARIX-T L Plus high-level sensor:

- (1) First remove the high-level sensor from the separator.
- (2) Check the sensor for dirt and clean it if necessary (see section 3.3).
- (3) To test the sensor, immerse it in water.
After the alarm delay time set on the measuring transducer ² (default setting 1 minute), the appropriate alarm signal ³ must be triggered by the measuring transducer.
- (4) As a counter check, remove the high-level sensor from the water.
After the sensor has heated up again, the alarm signal at the measuring transducer must revert to its original state ³. In addition to the alarm delay time set on the measuring transducer ², it can take up to 2 minutes for the sensor to reheat, depending on ambient temperature.

¹ Whenever the sensor is removed from the separator, the sensor has been contaminated with watery dirt in the course of time. It is necessary to clean the sensor so that it responds quickly during the test. Otherwise, depending on the degree of contamination, it could take several hours before an alarm is triggered, i.e. until the water evaporates and the dirt has dried. The same applies if the dirty sensor is immersed in light liquid. In this case, the light fluid has to displace the water from the dirt first, which can also take several hours.

² The measuring transducer delays the triggering and clearance of the alarm in order to prevent false alarms caused by occasional wave movements or splash of fluids. The measuring transducer configuration settings allow the alarm delay to be deactivated for test or demonstration purposes. For normal operation, the alarm delay of the measuring transducer should always remain activated in order to prevent false alarms.

³ Normally, the measuring transducer triggers an alarm whenever the interface sensor is in air/light fluid, or whenever the level sensor is in fluid. For custom applications, measuring transducer configuration settings make it possible to invert the alarm triggering so that an alarm is triggered whenever the interface sensor is in water or the high-level sensor is in air. In cases of doubt, check whether the measuring transducer has been configured correctly for the application concerned.

6 List of figures

Figure 1: SEPARIX-C L Plus, dimensions	3
Figure 2: SEPARIX-T L Plus, dimensions.....	4
Figure 3: SEPARIX-C, installation	6
Figure 4: SEPARIX-T, installation.....	7
Figure 5: SEPARIX-Control CT, top view	11
Figure 6: SEPARIX-Control CT, terminals and "Options" DIP switch	14
Figure 7: SEPARIX-Control CT, fault and alarm display.....	17

7 List of tables

Table 1: SEPARIX-Control CT, configuration	13
--	----

EG – Konformitätserklärung **EC – Declaration of Conformity**

In Übereinstimmung mit EN 45 014; 1998 - *In accordance with EN 45 014; 1998*

FAFNIR GmbH
Bahrenfelder Str. 19
D 22765 Hamburg

erklärt in eigener Verantwortlichkeit, daß das Produkt
declare under sole responsibility that the product

Trennschichtsensor mit Messumformer
Oil Layer Sensor with Measuring Transducer

SEPARIX-C ... / SEPARIX-Control C

in Übereinstimmung mit nachfolgenden Richtlinien:
in accordance with the following directives:

EMV-Richtlinie; *EMC Directive 89/336/EWG/EEC*
Ex-Richtlinie; *Ex Directive 94/9/EG/EC*

nach folgenden Vorschriften (Normen) entwickelt und gefertigt wurden:
has been designed and manufactured to the following specifications:

EN 50 014; 1997+A1+A2	EN 61 000-4-4, 2001
EN 50 020; 2002	EN 61 000-4-5; 2001
EN 50 284; 1999	EN 61 000-4-6; 2001
EN 61 000-4-2; 2001	EN 61 000-4-11; 2001
EN 61 000-4-3; 2001	EN 61 326, Klasse B

Das Produkt entspricht der EG-Baumusterprüfbescheinigung
The above mentioned product is in conformity with EC-Type Examination Certificate

TÜV 03 ATEX 2368 X / TÜV 03 ATEX 2369

Die Prüfung erfolgte durch die benannte Stelle Nr.: 0032
The inspection was carried out by the notified body No 0032

TÜV Hannover/Sachsen-Anhalt e.V.
TÜV Cert-Zertifizierungsstelle
Am TÜV 1
D – 30519 Hannover

Hamburg, 04.03.2004

Ort, Datum / Place, Date

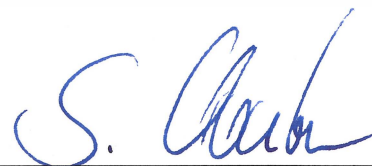

Geschäftsführer / Managing Director: S. Kunter

Translation

(1) **EU-Type Examination Certificate**

(2) Equipment and protective systems intended for use in potentially explosive atmospheres, **Directive 2014/34/EU**



(3) **Certificate Number** TÜV 03 ATEX 2368 X **issue:** 00

(4) for the product: Interface Sensor type SEPARIX-C ...

(5) of the manufacturer: **FAFNIR GmbH**

(6) Address: Schnackenburgallee 149 c, 22525 Hamburg, Germany

Order number: 8000481442

Date of issue: 2018-03-13

(7) The design of this product and any acceptable variation thereto are specified in the schedule to this EU-Type Examination Certificate and the documents therein referred to.

(8) The TÜV NORD CERT GmbH, Notified Body No. 0044, in accordance with Article 17 of the Directive 2014/34/EU of the European Parliament and the Council of 26 February 2014, certifies that this product has been found to comply with the Essential Health and Safety Requirements relating to the design and construction of products intended for use in potentially explosive atmospheres given in Annex II to the Directive.

The examination and test results are recorded in the confidential ATEX Assessment Report No. 18 203 216500.

(9) Compliance with the Essential Health and Safety Requirements has been assured by compliance with:

EN 60079-0:2012 + A11:2013

EN 60079-11:2012

except in respect of those requirements listed at item 18 of the schedule.

(10) If the sign "X" is placed after the certificate number, it indicates that the product is subject to the Specific Conditions for Use specified in the schedule to this certificate.

(11) This EU-Type Examination Certificate relates only to the design, and construction of the specified product. Further requirements of the Directive apply to the manufacturing process and supply of this equipment. These are not covered by this certificate.

(12) The marking of the product shall include the following:

 **II 1 G Ex ia IIB T4 Ga**

TÜV NORD CERT GmbH, Langemarckstraße 20, 45141 Essen, notified by the central office of the countries for safety engineering (ZLS), Ident. Nr. 0044, legal successor of the TÜV NORD CERT GmbH & Co. KG Ident. Nr. 0032

The head of the notified body



Roder

Hanover office, Am TÜV 1, 30519 Hannover, Tel. +49 511 998-61455, Fax +49 511 998-61590



I Range of application

The interface sensor is used as part of a monitoring system for oil/water separators and serves for the detection of an interface between water and light liquids. When the layer thickness of the light liquid reaches the switching point of the sensor, an alarm signal is produced via the associated measuring transducer.

II Standards

The equipment is designed in accordance with the following European standards

- EN 60079-0:2012 + A11:2013 Equipment - General Requirements
- EN 60079-11:2012 Equipment protection by intrinsic safety "i"

III Instructions for safe ...

III.a ... use

The interface sensor is designed as intrinsically safe apparatus and is approved for use in potentially explosive areas. The sensor may be used for gas groups IIA and IIB.

The approval applies to the device versions

- SEPARIX-C H Enclosure and cable protection for aggressive media
- SEPARIX-C L Plus Enclosure for non-aggressive media

III.b ... assembling and dismantling

Dismantling of the interface sensor is not provided. Dismantling would also damage the interface sensor and invalidate the approval.

III.c ... installation

All wiring operations must be carried out with the power disconnected. Special rules and regulations, including EN 60079-14 and local installation regulations, must be observed.

The interface sensor is suspended from its cable immersed in the liquid to be monitored. The sensor must be installed so that the switching point is (below the liquid surface) at the level at which the alarm is to be signalled as soon as any light liquid occurs there.

The interface sensor version 1 is equipped with a permanently connected blue cable (3 × 0.5 mm²). This cable is allowed to be shortened or lengthened. For cable extensions, a suitable junction box for the respective ambient conditions must be used. Version 2 is equipped with an M12 connector.

When wiring the interface sensor to the measuring transducer (preferably blue coloured cable), the permissible inductance and capacitance must not be exceeded. The connection to the measuring transducer has to be proceeded in accordance to the measuring transducer instructions.

Version 1		Version 2		
Colour	Wire	Pin	Wire	M12-Cable (Female)
White	Power supply +	1	Power supply +	
Green	Frequency signal	2	A / frequency signal	
Brown	Power supply -	3	Power supply -	
		4	B	

Table III.c: Terminal assignment of the sensor

The integration of the interface sensor into the equipotential bonding is not required.



III.d ... adjustment

For operating the interface sensor no Ex-relevant adjustments are required.

III.e ... putting into service

Before putting into service, all devices must be checked of right installation and connection. The electrical supply, as well of connected devices, must be checked.



III.f ... maintenance (servicing and emergency repair)

As part of regular maintenance of the Oil/Water Separator, the interface sensor must thoroughly be cleaned using a moist cloth. Grease-dissolving cleansing agents can be used to remove any firmly clinging grease or oil residues. Sharp-edged objects are unsuitable for the purpose of cleaning since they could damage the sensor.

In case of a defect, the interface sensor must be sent back to FAFNIR or one of its representatives.

There is compliance with the requirements for the dielectric strength between the intrinsically safe circuit and the chassis of the interface sensor with 500 V_{AC} in accordance with EN 60079-11, section 6.3.13.

IV Equipment marking

1	Manufacturer:	FAFNIR GmbH, 22525 Hamburg		
2	Type designation:	SEPARIX-C ...		
3	Certificate number:	TÜV 03 ATEX 2368 X		
4	Ex marking:		II 1 G	Ex ia IIB T4 Ga
5	CE marking:	 0044		
6	Technical Data	$U_i \leq 15 \text{ V}$	$I_i \leq 30 \text{ mA}$	$P_i \leq 100 \text{ mW}$
		$L_i < 100 \text{ } \mu\text{H}$	$C_i < 10 \text{ nF}$	$T_a \leq +60 \text{ } ^\circ\text{C}$

V Technical data

The safety-related values are defined with:

Input voltage	$U_i \leq 15 \text{ V}$
Input current	$I_i \leq 30 \text{ mA}$
Input power	$P_i \leq 100 \text{ mW}$

The externally effective capacitance and inductance are:

Internal capacity	$C_i \leq 10 \text{ nF}$
Internal inductance	$L_i \leq 100 \text{ } \mu\text{H}$

The interface sensor may be used in the following temperature ranges:

Ambient temperature	$-20 \text{ } ^\circ\text{C} \leq T_a \leq +60 \text{ } ^\circ\text{C}$
Medium temperature	$0 \text{ } ^\circ\text{C} \leq T_F \leq +60 \text{ } ^\circ\text{C}$

General information (see also EN 60079-0, section 1):

Zone 0 exists only under atmospheric conditions:

Temperature range	$-20 \text{ } ^\circ\text{C} \dots +60 \text{ } ^\circ\text{C}$
Pressure range	0,8 bar ... 1,1 bar
Oxidants	Air (oxygen content approx. 21 %)

The interface sensor achieves a degree of protection provided by enclosure:

Degree of protection	IP68
----------------------	------

VI Specific conditions for use

None.



**EU-Konformitätserklärung
EU Declaration of Conformity
Déclaration UE de Conformité**

FAFNIR GmbH
Schnackenburgallee 149 c
22525 Hamburg
Deutschland / Germany / Allemagne

erklärt als Hersteller in alleiniger Verantwortung, dass die Produkte
declares as manufacturer under sole responsibility that the products
déclare sous sa seule responsabilité en qualité de fabricant que les produits

**Grenzwertgeber bzw. Standaufnehmer bzw. Aufstau-Sensor /
Overfill Prevention Sensors resp. Level Detector resp. High Level Sensor /
Capteurs de valeur limite resp. Détecteur de niveau resp. Capteur de niveau haut
81 D-Ex ... & 83 UV-... / 76 ... & LS 300 ... / SEPARIX-T ...**

den Vorschriften der europäischen Richtlinien
comply with the regulations of the European directives
sont conformes aux réglementations des directives européennes suivantes

2011/65/EU	Beschränkung der Verwendung bestimmter gefährlicher Stoffe in Elektro- und Elektronikgeräten	RoHS
2011/65/EU	Restriction of the use of certain hazardous substances in electrical and electronic equipment	RoHS
2011/65/UE	Limitation de l'utilisation de certaines substances dangereuses dans les équipements électriques et électroniques	RoHS
2014/34/EU	Geräte und Schutzsysteme zur bestimmungsgemäßen Verwendung in explosionsgefährdeten Bereichen	ATEX
2014/34/EU	Equipment and protective systems intended for use in potentially explosive atmospheres	ATEX
2014/34/UE	Appareils et systèmes de protection destinés à être utilisés en atmosphères explosibles	ATEX

durch die Anwendung folgender harmonisierter Normen entsprechen
by applying the harmonised standards
par l'application des normes

**RoHS / RoHS / RoHS
ATEX / ATEX / ATEX**

**EN 50581:2012
EN 60079-0:2012 + A11:2013
EN 60079-11:2012
EN 60079-26:2015**

Die Produkte sind bestimmt als Elektro- und Elektronikgeräte der RoHS-
The products are determined as electrical and electronic equipment of RoHS
Les produits sont déterminés comme des équipements électriques et électroniques de RoHS

Kategorie / Category / Catégorie

**Überwachungs- und Kontrollinstrumenten in der Industrie /
Industrial Monitoring and Control Instruments /
Instruments de contrôle et de surveillance industriels**

Die notifizierte Stelle TÜV NORD CERT GmbH, 0044 hat eine EU-Baumusterprüfung durchgeführt und folgende Bescheinigung ausgestellt
The notified body TÜV NORD CERT GmbH, 0044 performed a EU-type examination and issued the certificate
L'organisme notifié TÜV NORD CERT GmbH, 0044 a effectué examen UE de type et a établi l'attestation

81 D-Ex ... & 83 UV-... / LS 300 ... / SEPARIX-T ...

TÜV 00 ATEX 1656 X

Hamburg, 14.01.2019
Ort, Datum / Place, Date / Lieu, Date

Geschäftsführer / Managing Director / Gérant: René Albrecht

Translation

(1) **EU-Type Examination Certificate**

(2) Equipment and protective systems intended for use in potentially explosive atmospheres, **Directive 2014/34/EU**



(3) **Certificate Number** TÜV 00 ATEX 1656 X **issue:** 00

(4) for the product: Overfill Prevention Sensor type 81 D-Ex ... and type 83 UV-...
Level Detector type LS 300 ...
High-Level Sensor type SEPARIX-T ...

(5) of the manufacturer: **FAFNIR GmbH**

(6) Address: Schnackenburgallee 149 c, 22525 Hamburg, Germany

Order number: 8000488168

Date of issue: 2018-09-11

(7) The design of this product and any acceptable variation thereto are specified in the schedule to this EU-Type Examination Certificate and the documents therein referred to.

(8) The TÜV NORD CERT GmbH, Notified Body No. 0044, in accordance with Article 17 of the Directive 2014/34/EU of the European Parliament and the Council of 26 February 2014, certifies that this product has been found to comply with the Essential Health and Safety Requirements relating to the design and construction of products intended for use in potentially explosive atmospheres given in Annex II to the Directive.

The examination and test results are recorded in the confidential ATEX Assessment Report No. 18 203 228654.

(9) Compliance with the Essential Health and Safety Requirements has been assured by compliance with:

EN 60079-0:2012 + A11:2013

EN 60079-11:2012

EN 60079-26:2015

except in respect of those requirements listed at item 18 of the schedule.

(10) If the sign "X" is placed after the certificate number, it indicates that the product is subject to the Specific Conditions for Use specified in the schedule to this certificate.

11) This EU-Type Examination Certificate relates only to the design, and construction of the specified product. Further requirements of the Directive apply to the manufacturing process and supply of this equipment. These are not covered by this certificate.

(12) The marking of the product shall include the following:



See item 15 of the schedule

TÜV NORD CERT GmbH, Langemarckstraße 20, 45141 Essen, notified by the central office of the countries for safety engineering (ZLS), Ident. Nr. 0044, legal successor of the TÜV NORD CERT GmbH & Co. KG Ident. Nr. 0032

The head of the notified body

Roder

Hanover office, Am TÜV 1, 30519 Hannover, Tel. +49 511 998-61455, Fax +49 511 998-61590

This certificate may only be reproduced without any change, schedule included.
Excerpts or changes shall be allowed by the TÜV NORD CERT GmbH

(13) SCHEDULE

(14) EU-Type Examination Certificate No. TÜV 00 ATEX 1656 X issue 00

(15) Description of product

The sensors are intrinsically safe equipment that can be used in a potentially explosive area and are used to detect a limit level. The overflow prevention sensors (OPS) serve as part of an overflow prevention. The level detector is used as part of an overflow protection, dry run protection or filling control. The high-level sensor is used to detect backwater within a light liquid separator.

In the future, the sensors may also be manufactured in accordance with the test documents listed in the ATEX test report. The changes affect the addition of new types. Furthermore, the equipment was assessed according to the latest standards.

The marking is as follows:

Type 81 D-Ex resp. 83 UV-... resp. LS 300 ... resp. SEPARIX-T ...

 II 1 G Ex ia IIC T4 Ga resp.
 II 1/2 G Ex ia IIC T4 Ga/Gb

Type 81 D-Ex U resp. LS 300 ... U...

 II 1/2 G Ex ia IIC T4 Ga/Gb

Type LS 300 ... C

 II 1 G Ex ia IIB T4 Ga resp.
 II 1/2 G Ex ia IIB T4 Ga/Gb

Type designation:

Type 81 D-Ex ...:

81 D-Ex OPS made of stainless steel
 81 D-Ex U OPS additionally with overvoltage protection

Type 83 UV-...:

83 UV-A Stainless steel OPS with junction box and wall fitting
 83 UV-C Stainless steel OPS with permanently connected cable and wall fitting
 83 UV-SCR Brass OPS with permanently connected cable, reed contact / float and wall fitting
 83 UV-SR Brass OPS with reed contact / float
 83 UV-SV Brass OPS with variably adjustable junction box
 83 UV-SVR Brass OPS with variably adjustable junction box and reed contact / float

Type LS 300 ... (only Ex relevant designations):

LS 300 Level detector without process connection, test connection and overvoltage protection as well as normal medium temperature range
 LS 300 E... Level detector with screw-in unit
 LS 300 F... Level detector with flange
 LS 300 ...P... Level detector with test connection and without check valve
 LS 300 ...PR... Level detector with test connection and with check valve
 LS 300 ...U... Level detector with overvoltage protection
 LS 300 ...H... Level detector for high medium temperature range
 LS 300 ...HH... Level detector for the highest medium temperature range

Schedule to EU-Type Examination Certificate No. TÜV 00 ATEX 1656 X issue 00

LS 300 ... L...	Level detector for low medium temperature range
LS 300 ... C	Level detector with plastic coating
LS 300 ... Duo	Double level detector
LS 300 ... Steck	Level detector with plug connection
LS 300 ... Tantal	Level detector with at least sensor element made of tantalum
LS 300 ... Trio	Triple level detector
Type SEPARIX-T ...:	
SEPARIX-T H	High-level sensor with sensor tube made of stainless steel for aggressive media
SEPARIX-T L Plus	High-level sensor with sensor tube made of stainless steel for non-aggressive media

Technical data:

Signal- and power circuit	in type of protection "Intrinsic Safety" Ex ia IIC/IIB only for the connection to a certified intrinsically safe circuit Maximum values: $U_i = 30 \text{ V}$ $I_i = 200 \text{ mA}$ $P_i = 1 \text{ W}$ L_i negligibly small C_i negligibly small
---------------------------	--

The types LS 300 ... C with plastic coating are only for gas group IIB allowed.

Permissible ambient temperature range:

The ambient temperature range is -40 °C to $+110 \text{ °C}$. When using a sensor with overvoltage protection, the maximum temperature is $+90 \text{ °C}$.

When used in areas requiring category 1 or 1/2, the following applies:

The process pressure for the media must be between 0.8 bar and 1.1 bar where explosive vapour-air mixtures are present. If no explosive mixtures are present, the equipment may also be operated outside this area according to the manufacturer's specification.

All further data are valid unchanged.

(16) Drawings and documents are listed in the ATEX Assessment Report No. 18 203 228654

(17) Specific Conditions for Use

1. Overfill prevention sensors and level detectors with overvoltage protection do not comply with the dielectric strength requirements according to EN 60079-11, clause 6.3.13. When performing an insulation test on the intrinsically safe circuit, the device must be disconnected.
2. When using the integrated overvoltage protection, integration into the equipotential bonding is required.

(18) Essential Health and Safety Requirements

no additional ones

- End of Certificate -



Instructions in accordance with Directive 2014/34/EU

TÜV 00 ATEX 1656 X

Overfill Prevention Sensor Type 81 D-Ex ... and 83 UV-...

Level detector LS 300 ...

High-level sensor type SEPARIX-T ...

Edition: 09.2018

I Range of application

The sensors are intrinsically safe operating equipment for use in explosion hazardous area and serve for detecting the limit level. The Overfill Prevention Sensors serve as part of a filling safety device. The level detector is used as part of an overfill prevention system, dry run protection or filling control. The high-level sensor is used to detect a fluid back pressure within a light liquid separator.

II Standards

The sensors are designed in accordance with the following European standards

EN 60079-0: 2012 + A11:2013	Equipment - General Requirements
EN 60079-11: 2012	Equipment protection by intrinsic safety "i"
EN 60079-26: 2015	Equipment with Equipment Protection Level (EPL) Ga

III Instructions for safe ...

III.a ... use

The sensors are designed as intrinsically safe equipment and are suitable for use in potentially explosive areas. The level detectors LS 300 ... C (coated with plastic) are suitable for the gas groups IIA and IIB. All other level detectors are suitable for all gas groups (IIA, IIB and IIC).

The approval applies to device versions 81 D-Ex ..., 83 UV-..., LS 300 ... and SEPARIX-T ...

III.b ... assembling and dismantling

Assembling and dismantling must solely be carried out with the power disconnected!

For sensors with connection housing the cover of the connection housing may be removed for the electrical installation. After installation, the connection housing must be locked again.

III.c ... installation

The wiring must be carried out only with the power disconnected. Special rules and regulations, including EN 60079-14 and local installation regulations, must be observed.

The sensors can be installed completely inside Zone 0. If the integrated overvoltage protection is used, e. g. LS 300 U, the terminal compartment with overvoltage protection must be installed outside Zone 0.

General information (see also EN 60079-14:2014, section 16.3 or EN 60079-25:2010, section 12):

The overvoltage protection device must be installed outside, but as close to the border of Zone 0 as technically possible, preferably at a distance of up to 1 m.

If a screw-in unit is used, it must be provided with a suitable sealing material and screwed into the tank coupling. If the sensor tube is permanently connected with a flange, the installation length cannot be changed. The flange shall be provided with a suitable seal and fixed with flange bolts or nuts.

By the process connection, there may be an opening in the boundary wall to the area requiring EPL "Ga". Then, there is the risk of flammable gases release and flame entrance.

If the sensor is supplied without process connection, the installer is responsible for compliance with the EX requirements.



General information (see also EN 60079-26, section 4.3):

Attention must be paid, if the sensor is installed in the separating wall between Zone 0 and Zone 1. Then a protection class of at least IP66 or IP67 must be achieved after installation.

When wiring the sensor to the measuring transducer (preferably blue coloured cable), the approved inductance and capacitance of the measuring transducer must not be exceeded.

The sensors have a two-pole screw or plug connection or cable tail. Attention does not need to be paid to polarity.

The integration of the sensors without overvoltage protection into the equipotential bonding is not required. For integration of the sensors with overvoltage protection into the equipotential bonding, a PA terminal is provided.

III.d ... adjustment

No Ex-relevant adjustments are required for operation of the sensors.

III.e ... putting into service

Before putting into service, all devices must be checked of right installation and connection. The electrical supply, as well as connected devices, must be checked.





III.f ... maintenance (servicing and emergency repair)

The sensors are generally maintenance-free. In case of a defect, the sensors must be sent back to the manufacturer or one of its representations.

The sensors, in particular the probe tip, may be cleaned. Grease-dissolving cleansing agents can be used to remove any firmly clinging grease or oil residues. Sharp-edged objects are unsuitable for the purpose of cleaning since they could damage the sensor.

When performing an insulation test of the intrinsically safe circuit with 500 V under well-controlled conditions, according to EN 60079-25, section 12 it is necessary to disconnect sensors with overvoltage protection since there is no compliance with the requirements for dielectric strength according to EN 60079-11, section 6.3.13. For all other sensors, there is compliance between the intrinsically safe circuit and the chassis or, if present, other intrinsically safe circuits with 500 V_{AC}.

IV Equipment marking

1	Manufacturer:	FAFNIR GmbH, 22525 Hamburg
2	Type designation:	81 D-Ex ... or 83 UV-... or LS 300 ... or SEPARIX-T ...
3	Certificate number:	TÜV 00 ATEX 1656 X
4	Ex marking:	
		81 D-Ex / 83 UV-... / LS 300 ... / SEPARIX-T ...
		 II 1 G Ex ia IIC T4 Ga
		II 1/2 G Ex ia IIC T4 Ga/Gb
		81 D-Ex U / LS 300 ...U...
		 II 1/2 G Ex ia IIC T4 Ga/Gb
		LS 300 ... C
		 II 1 G Ex ia IIB T4 Ga
		II 1/2 G Ex ia IIB T4 Ga/Gb
5	CE marking:	 0044
6	Technical Data:	$U_i \leq 30 \text{ V}$
		$I_i \leq 200 \text{ mA}$
		$P_i \leq 1 \text{ W}$



V Technical data

The following electrical input values apply to the sensors:

$$\begin{aligned}U_i &\leq 30 \text{ V} \\I_i &\leq 200 \text{ mA} \\P_i &\leq 1 \text{ W}\end{aligned}$$

The effective internal capacitance and inductance that are externally effective, are negligibly small. If the sensors are supplied with integrated cable, then the electrical characteristics are:

$$\begin{aligned}C_c &= 200 \text{ pF/m} \\L_c &= 1 \text{ }\mu\text{H/m} \\L_c/R_c &= 30 \text{ }\mu\text{H}/\Omega\end{aligned}$$

The sensors may be used in the following ambient temperature range:

$$T_a = -40 \text{ }^\circ\text{C} \dots +110 \text{ }^\circ\text{C}$$

When using a sensor with overvoltage protection, the maximum temperature is +90 °C for the sensor head.

General information (see also EN 60079-0, section 1):

Zone 0 exists only under atmospheric conditions:

Temperature range:	-20 °C ... +60 °C
Pressure range:	0.8 bar to 1.1 bar
Oxidants:	Air (oxygen content approx. 21 %)

The sensors achieve a housing protection of:

Degree of protection: IP68

The following technical data apply to sensors with overvoltage protection:

The nominal DC spark-over voltage amounts to:

$$U = 350 \text{ V} \pm 20 \%$$

The nominal impulse discharge current amounts to:

$$I = 20 \text{ kA} (10 \times \text{Wave } 8/20 \text{ }\mu\text{s})$$

The nominal alternating discharge current amounts to:

$$I = 20 \text{ A} (10 \times @ 50 \text{ Hz}, 1 \text{ s})$$

The insulation resistance of an overvoltage arrester amounts to:

$$R > 10 \text{ G}\Omega$$

VI Specific conditions for use

1. Overfill Prevention Sensor and Level detectors with overvoltage protection do not comply with the dielectric strength requirements according to EN 60079-11, section 6.3.13. When performing an insulation test of the intrinsically safe circuit it is therefore necessary to disconnect the device.
2. When using the integrated overvoltage protection, integration into the equipotential bonding is required.

Translation

(1) **EC-Type Examination Certificate**



(2) Equipment and protective systems intended for use in potentially explosive atmospheres
- Directive 94/9/EC



(3) EC-Type Examination Certificate Number

TÜV 05 ATEX 2819

(4) Equipment: **measuring transducer SEPARIX-Control CT**

(5) Manufacturer: **FAFNIR GmbH**

(6) Address: **Bahrenfelder Strasse 19, D-22765 Hamburg**

(7) This equipment or protective system and any acceptable variation thereto are specified in the schedule to this certificate and the documents therein referred to.

(8) The TÜV NORD CERT GmbH & Co. KG, TÜV CERT-Certification Body, notified body number N° 0032 in accordance with Article 9 of the Council Directive of the EC of March 23, 1994 (94/9/EC), certifies that this equipment or protective system has been found to comply with the Essential Health and Safety Requirements relating to the design and construction of equipment and protective systems intended for use in potentially explosive atmospheres given in Annex II to the Directive.

The examination and test results are recorded in the confidential report N° 05 YEX 551985-5.

(9) Compliance with the Essential Health and Safety Requirements has been assured by compliance with:

EN 50 014:1997+A1+A2 EN 50 020:2002

(10) If the sign "X" is placed after the certificate number, it indicates that the equipment or protective system is subject to special conditions for safe use specified in the schedule to this certificate.

(11) This EC-type examination certificate relates only to the design, examination and tests of the specified equipment in accordance to the Directive 94/9/EC. Further requirements of the Directive apply to the manufacturing process and supply of this equipment. These are not covered by this certificate.

(12) The marking of the equipment or protective system must include the following:

 **II (1) G [EEx ia] IIC/IIB**

TÜV NORD CERT GmbH & Co. KG
Am TÜV 1
D-30519 Hannover
Tel.: +49 (0) 511 986-1455
Fax: +49 (0) 511 986-1590

Hanover, 2005-01-06

Head of the
Certification Body

(13)

SCHEDULE

(14) **EC-Type Examination Certificate N° TÜV 05 ATEX 2819**

(15) Description of equipment

The measuring transducer SEPARIX-Control CT is used for the power supply and analysis of oil separator sensors of the type SEPARIX-C... and analysis of high-level sensors of the type SEPARIX-T...

Electrical data

Auxiliary power circuit
(terminals L, N, and PE)

$U = 230 \text{ V AC}, \pm 10 \%, 50...60 \text{ Hz}, \text{ approx. } 8 \text{ VA}$
 $U_m = 253 \text{ V}$

SEPARIX-C...
Sensor circuit
(terminals 1, 2 and 3)

in the type of protection intrinsic safety EEx ia IIC
or EEx ia IIB

Maximum values: $U_o = 14.3 \text{ V}$
 $I_o = 21.2 \text{ mA}$
 $P_o = 75.7 \text{ mW}$

Characteristic: linear

$C_i \leq 1 \text{ nF}$
 L_i negligibly small

The permissible maximum values for the outer inductance (L_o) and capacitance (C_o) are included in the following table:

	EEx ia IIC	EEx ia IIB
L_o	80 mH	300 mH
C_o	0.68 μF	4.28 μF

SEPARIX-T...
Sensor circuit
(terminals 4 and 5)

in the type of protection intrinsic safety EEx ia IIC
or EEx ia IIB

Maximum values: $U_o = 15.8 \text{ V}$
 $I_o = 154 \text{ mA}$
 $R_i = 157 \text{ } \Omega$
 $P_o = 600 \text{ mW}$

Characteristic: trapezoidal

$C_i \leq 0.3 \text{ nF}$
 L_i negligibly small

Schedule EC-Type Examination Certificate N° TÜV 05 ATEX 2819

The permissible maximum values for the outer inductance (L_o) and capacitance (C_o) are included in the following table:

EEx ia IIC		EEx ia IIB	
L_o	0.1 mH	0.44 mH	1 mH
C_o	310 nF	230 nF	1.6 μ F

Output circuit
(terminals 6 to 11)

$U \leq 250$ V, $I \leq 5$ A, $P \leq 500$ VA, $\cos \varphi \geq 0.7$
 $U_m = 253$ V

The sensor circuits are DC-isolated from the auxiliary power circuit and from the output circuit safely up to a peak value of 375 V.

(16) Test documents are listed in the test report N° 05 YEX 551985-5.

(17) Special conditions for safe use

none

(18) Essential Health and Safety Requirements

no additional ones

Measuring transducer SEPARIX-Control CT

Mode of operation

The measuring transducer SEPARIX-Control CT is used for the power supply and analysis of the oil separator sensor SEPARIX-C .. and the high-level sensor SEPARIX-T .. . Alarms and malfunctions are signalled optically and acoustically by means of light-emitting diodes and a built-in buzzer. External alarm transmitters can be connected via potential-free changeover contacts, which are switched in the case of an alarm. The acoustic alarm can be acknowledged using the Alarm button. The optical alarm remains on until the cause of the alarm has been eliminated. An internal switch can be used for an optional setting to determine whether or not external alarm transmitters can be reset at the potential-free changeover contacts. Additional internal setting options are the automatic alarm repeating function after 24 hours, changeover contact switched in the alarm or normal state, and whether the alarm is to be activated for the detection of liquid or air. The function test for the internal and external alarm functions can be carried out using the Test button.

Installation

Connecting the auxiliary power, the oil separator sensor, the high-level sensor and an optional, external alarm transmitter must be carried out according to the connection diagram. The maximum values for the operating parameters mentioned on the wiring diagram must be observed.

Wiring work may only be performed with the equipment in de-energized condition. The special VDE regulations and the local installation regulations must be observed.

Operating instructions

Before being put into service, all devices must be checked with respect to correct connection and proper operation. The electrical power supply, including the supply of the downstream devices, must be checked.

The general operating instructions for the devices being used must be observed. The measuring transducer is maintenance-free.

Technical data

Auxiliary power	230 V; 50 – 60 Hz; $\pm 10 \%$; 8 VA			
Sensor circuits				
SEPARIX-C ..				
Voltage	$U_o \leq 14.3 \text{ V}$			
Current	$I_o \leq 21.2 \text{ mA}$			
Power	$P_o \leq 75.5 \text{ mW}$			
Internal resistance	$R_i \geq 673 \Omega$			
Inductance (outward acting)	L_i negligible			
Capacitance (outward acting)	$C_i \leq 1 \text{ nF}$			
		IIC	IIB	
Outer inductance	$L_o \leq 80 \text{ mH}$		$\leq 300 \text{ mH}$	
Outer capacitance	$C_o \leq 0.68 \mu\text{F}$		$\leq 4.28 \mu\text{F}$	
SEPARIX-T ..				
Voltage	$U_o \leq 15.75 \text{ V}$			
Current	$I_o \leq 0.154 \text{ A}$			
Power	$P_o \leq 0.61 \text{ W}$			
Internal resistance	$R_i \geq 156.8 \Omega$			
Inductance (outward acting)	L_i negligible			
Capacitance (outward acting)	$C_i \leq 0.3 \text{ nF}$			
			IIC	IIB
Maximum outer inductance	$L_o \leq 440 \mu\text{H}$	$\leq 100 \mu\text{H}$	$\leq 5 \text{ mH}$	$\leq 1 \text{ mH}$
Maximum outer capacitance	$C_o \leq 230 \text{ nF}$	$\leq 310 \text{ nF}$	$\leq 760 \text{ nF}$	$\leq 1.6 \mu\text{F}$

Output circuits potential-free changeover contact

Alternating voltage: $U_{\text{eff}} \leq 250 \text{ V}; I_{\text{eff}} \leq 5 \text{ A}; P_{\text{eff}} \leq 500 \text{ VA}; \cos \varphi \geq 0.7$

Direct voltage $U \leq 250 \text{ V}; I \leq 0.25 \text{ A}; P \leq 50 \text{ W}$

Ambient temperature 0 – 40 °C

Labelling:

EC type test certificate no.: TÜV 05 ATEX 2819

In compliance with EC Directive 94/9:  0032  II (1) G [EEx ia] IIC / IIB

Blank Page



Blank Page

Blank Page



FAFNIR GmbH
Schnackenburgallee 149 c
22525 Hamburg, Germany
T: +49 / 40 / 39 82 07-0
F: +49 / 40 / 390 63 39
E-mail: info@fafnir.com
Web: www.fafnir.com
