

VISY-X

VISY Probes



Version: 15
Edition: 2023-01
Art. no.: 207194

Table of contents

1	Introduction.....	1
1.1	Related Documentation	2
1.2	Safety Instructions	3
2	Versions of the VISY-X System.....	4
2.1	Wired Version.....	4
2.2	Wireless Version / Radio System	4
3	Level Sensors	5
3.1	Design and Function.....	5
3.2	Installation Method.....	6
3.3	Types.....	6
3.3.1	VISY-Stick / Biodiesel / E15.....	7
3.3.2	VISY-Stick Advanced / Advanced Biodiesel / Advanced E15.....	8
3.3.3	VISY-Stick Ethanol	9
3.3.4	VISY-Stick Advanced Ethanol	10
3.3.5	VISY-Stick N for AdBlue® Urea Solution.....	11
3.3.6	VISY-Stick Flex / Flex Biodiesel / Flex E15.....	12
3.3.7	VISY-Stick LPG.....	13
3.3.8	VISY-Density (LPG) module.....	13
4	Environmental Sensors.....	14
4.1	Types.....	14
4.1.1	VISY-Stick Interstitial	15
4.1.2	VISY-Reed Interstitial Dry	16
4.1.3	VISY-Stick Sump Manhole / Dispenser.....	17
4.1.4	VISY-Reed Sump Manhole / Dispenser.....	18
4.1.5	VISY-Stick Oil.....	19
5	Installation	20
5.1	Installation and Safety Instructions.....	20
5.2	Variants.....	21
5.2.1	Installation with screw-in Unit	22
5.2.2	Riser Installation.....	23
5.2.3	Installing VISY-Stick N and VISY-Stick LPG without Installation Kit	24
5.2.4	Installation of VISY-Stick Flex.....	24
5.2.5	Sensor Replacement Instructions.....	26
5.2.6	Installation Kit for VISY-Stick Sump.....	26

5.2.7	Variable LPG Installation Kit for Liquid Gas Containers.....	27
5.2.8	1" Installation Kit.....	29
5.3	Electrical Connection.....	29
5.3.1	Voltage Surge Protection.....	30
5.4	Installation Offset.....	31
6	Maintenance	32
6.1	Servicing.....	32
6.2	Return Shipment.....	32
7	List of Figures	32
8	List of tables.....	32
9	Annex.....	33
9.1	VISY-Stick.....	33
9.1.1	EU Declaration of Conformity.....	33
9.1.2	EU-Type Examination Certificate.....	34
9.1.3	Instructions.....	40
9.1.4	Petroleum & Explosives Safety Organisation (PESO) Approval	47
9.2	VISY-Reed.....	49
9.2.1	EU Declaration of Conformity.....	49
9.2.2	EU-Type Examination Certificate.....	50
	1. Supplement.....	52
9.2.3	Instructions.....	54
9.3	Technical Data.....	57

© Copyright:

Reproduction and translation are permitted only with the written consent of the FAFNIR GmbH. The FAFNIR GmbH reserves the right to make product alterations without prior notice.

1 Introduction

The VISY-X system (**V**olume **I**nformation **S**ystem) provides highly precise and continuous level measurements for all commercially available fuels in up to 16 tanks. Simultaneously the product temperature and the water level at the bottom of the tank are measured.

The system includes:

- **VISY-Command** (central unit)
- **VISY-Setup** (software application) for configuring the VISY-Command
- **VISY-Stick** (filling-level sensors) for tank gauging in the versions:
VISY-Stick, VISY-Stick Advanced, VISY-Stick Advanced with VISY-Density Module, VISY-Stick Flex, VISY-Stick LPG (liquefied petroleum gas), ...

In addition, following environmental sensors can also be operated with the VISY-X System:

- **VISY-Stick Sump** for monitoring the manhole or the dispenser sump with the distinction between product and water
- **VISY-Reed Sump** for monitoring the manhole or the dispenser sump without a distinction between liquids
- **VISY-Stick Interstitial** (with adjustable measuring range) for monitoring the intermediate chamber in double-walled tanks
- **VISY-Reed Interstitial** (with fixed measuring points) for monitoring the intermediate chamber in double-walled tanks
- **VIMS Sensors** (VIMS-Tank, VIMS-Product Pipe, VIMS-Delivery Pipe) for monitoring the intermediate chamber in double-walled tanks, filling lines and product lines from our system partner SBG GmbH, see chapter 1.1
- **COMS (Continuous Oil Separator Monitoring System) with VISY-Stick Oil and VISY-Sludge probes** for monitoring the oil and sludge layer in oil separators, see chapter 1.1
- **VPS** for monitoring pressure, see chapter 1.1

The sensors can be installed easily both using the screw-in unit with external thread and through a pipe installation (riser). The sensors may be operated in potentially explosive areas including Zone 0.

In this manual, you are guided through installation and commissioning of the VISY-Stick and VISY-Reed Sensors. This manual contains a description of all steps needed to perform the installation.

1.1 Related Documentation

The VISY probes have to be connected with the VISY-Command central unit which is mounted inside the petrol station building. Before operating, the VISY-Command must be configured using a PC or notebook and the VISY-Setup software application. The VISY-Command collects data from the sensors and transmits this to a higher-level system (e.g. POS) on request. Please follow the instructions in the following technical documentation:



VISY-Command VI-4, art. no. 207184



VISY-Setup V4..., art. no. 207158

For the installation and commissioning of the VIMS sensors please contact:



SGB GmbH, Hofstraße 10, 57076 Siegen, Germany

T.: +49 271 48964-0, F.: +49 271 48964-6, E.: sgb@sgb.de

The VISY-SoftView software application is used for the display module in the VISY-Command GUI and in the VISY-View Touch. VISY-SoftView provides the capability to view current tank data, delivery data and the various alarms signalled by the VISY-Command central unit. For configuration and operation of the display module with VISY-SoftView, see the following technical documentation:



VISY-SoftView User Guide, art. no. 350026



VISY-SoftView Administrator, art. no. 350144

The probes VISY-Stick Oil and VISY-Sludge are used for the monitoring of oil separators (**COMS Continuous Oil Separator Monitoring**). The sensor VISY-Stick Oil continuously monitors the height of the light-liquid layer, VISY-Sludge continuously monitors the height of the sludge layer. For installation and operation see the following technical documentation:



COMS Technical data (multilingual), art. no. 350273



COMS Installation Quick Guide, art. no. 350240



COMS oil layer table, art. no. 350007

The VPS sensor is suitable for the monitoring of hydrostatic pressures. The sensor continuously monitors the pressure of a liquid column. For installation and operation see the following technical documentation:



VPS pressure sensor, art. no. 350204

1.2 Safety Instructions

The VISY-X system is optimised for use in petrol stations and is compatible with all commercially available fuels. It serves to measure and evaluate the filling levels in tanks. The system must be used exclusively for this purpose. Observe and follow all product safety notes and operating instructions. The manufacturer accepts no liability for any form of damage resulting from improper use.

The level and environmental sensors have been developed, manufactured and tested in accordance with the latest good engineering practices and generally accepted safety standards. Nevertheless, hazards may arise from their use.

The following safety precautions must be observed in order to reduce the risk of injury, electric shocks, fire or damage to the equipment:

- The VISY-X system should only be installed by trained service engineers.
- Operation and servicing should only be carried out by expert personnel.
- The product may be powered only via the permissible auxiliary power supply.
- Operators, installers and service technicians must observe all applicable safety regulations. This also applies to any local safety and accident prevention regulations which are not stated in this manual.
- Do not change or modify the system or add any equipment without the prior consent of the manufacturer.
- Only use original parts. These comply with the technical requirements specified by the manufacturer.

The safety instructions in this user guide are marked as follows:



If these safety instructions are not observed, it may result in the risk of accident or damage to the VISY-X system.



Useful tips and information in this user guide you should observe, appear in italics and are identified by this symbol.

REACH Regulation



The sensors VISY-Stick contain a lead-titanium-zirconium oxide, which belongs to the substances of very high concern (SVHC) according to Regulation (EC) No. 1907/2006 (REACH). You will find a corresponding note on our website at www.fafnir.com.

2 Versions of the VISY-X System

Two versions of the VISY-X system are available which differ in different data transmission technology:

- (1) The wired version
- (2) The wireless version / radio system

2.1 Wired Version

In most cases, data is transferred between the sensors and the VISY-Command central unit via cable. This cable is also in charge of the voltage supply of the sensors. The wired version of the VISY-X system is the standard version.

2.2 Wireless Version / Radio System

If no free cable ducts are available at the petrol station, it is possible to instead opt for the wireless tank gauging system. In this case, the benefit of installing the wireless system is that it does not entail any excavation work.

In the wireless system, the sensors are connected to a transmitter and powered by a battery. The radio version of the central unit is equipped with a receiving module.

The radio system consists of the additional components:

- VISY-RFR (radio frequency receiver, receiver installed in VISY-Command ... RF)
- VISY-RFT (radio frequency transmitter, transmitter with battery)

The installation procedure for the wireless system is described in the following technical documentation:



VISY-RF III radio system, art. no. 350272

3 Level Sensors

3.1 Design and Function

The sensors consist of a probe head (1) and a probe tube (4) made of stainless steel. The probe tube is fitted in the tank with a screw-in unit (3) for height adjustment. For riser installation, the screw-in unit is not required. A float (5) for measuring the product filling level and an additional float (6) for continuous water detection move on this probe tube. In the case of products having a density greater than 0.9 kg/l, water detection cannot take place and the water float must be removed.

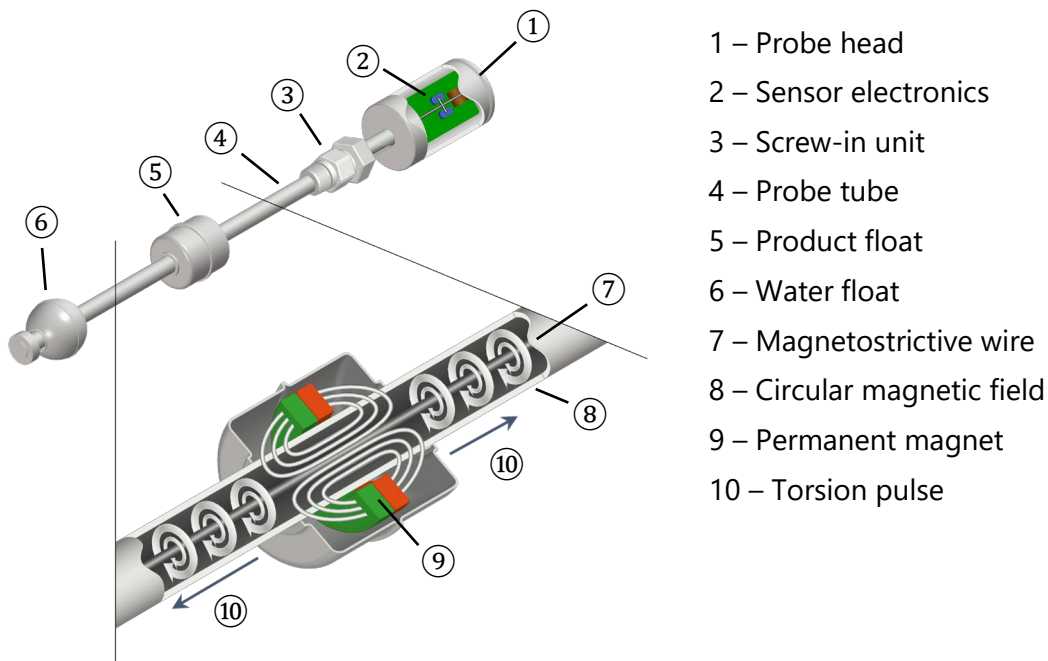

Figure 1: Mode of operation of the magnetostrictive measuring principle

The sensor operates according to the magnetostrictive measuring principle. The probe tube contains a wire (7) made of magnetostrictive material. The sensor electronics (2) transmits pulses through the wire, which generate a circular magnetic field (8). Permanent magnets (9) are used as filling level sensors which are installed in both the product float (5) and the water float (6). The magnetic fields of the float magnets (9) axially magnetise the wire in this area. Due to the overlapping of the two magnetic fields, a torsion pulse (10), which runs in both directions through the wire from the float position, is created in the area of the float magnets. One torsion pulse runs directly to the probe head and the other one is reflected at the bottom end of the probe tube. The time between the current pulse being transmitted and the two torsion pulses arriving at the probe head is measured and the float position calculated. The position of the water float is calculated by measuring a second pulse.

3.2 Installation Method

Depending on the installation method, the sensors can be delivered in the following versions:

- for the Riser installation
- with screw-in unit for mounting on the tank lid

3.3 Types

The following level sensors then are described:

- VISY-Stick / Biodiesel / E15
- VISY-Stick Advanced / Advanced Biodiesel / Advanced E15
- VISY-Stick Ethanol
- VISY-Stick Advanced Ethanol
- VISY-Stick N for AdBlue®:
- VISY-Stick Flex / Flex Biodiesel / Flex E15
- VISY-Stick LPG
- VISY-Stick Advanced with VISY-Density Module

3.3.1 VISY-Stick / Biodiesel / E15

The VISY-Stick level sensor is designed for level measurement of petrol and diesel fuels. A special version is available for biodiesel or E15 (petrol-ethanol mixture with 0 ... 15 % Ethanol). The sensor is available for riser installation and for installation with screw-in unit.

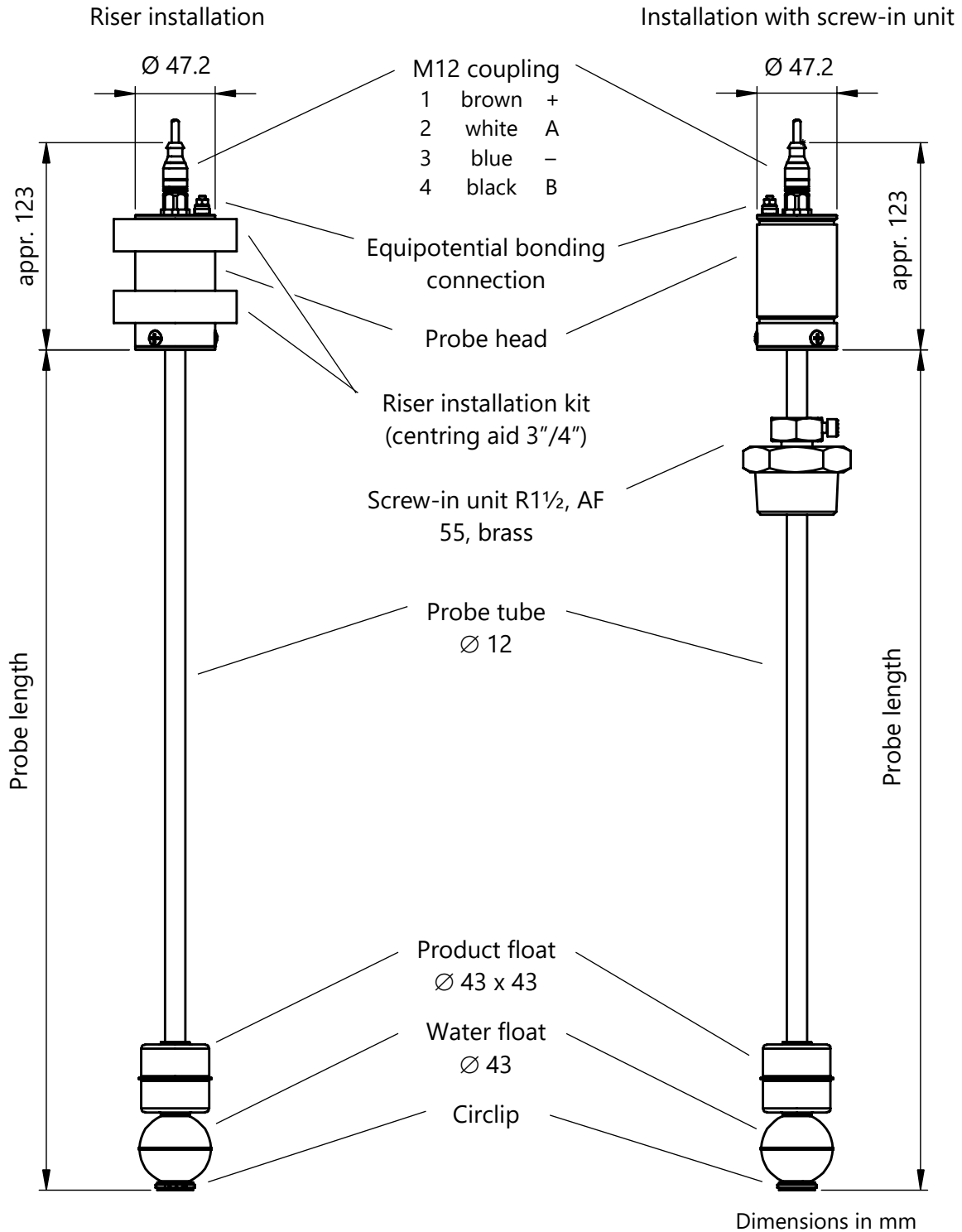

Figure 2: VISY-Stick / Biodiesel / E15

3.3.2 VISY-Stick Advanced / Advanced Biodiesel / Advanced E15

The sensor VISY-Stick Advanced is equipped with a higher measuring accuracy than VISY-Stick. It is designed for the level measurement of petrol and diesel fuels. A special version is available for biodiesel or E15 (petrol-ethanol mixture with 0 ... 15 % Ethanol). The sensor is available for riser installation and for installation with screw-in unit.

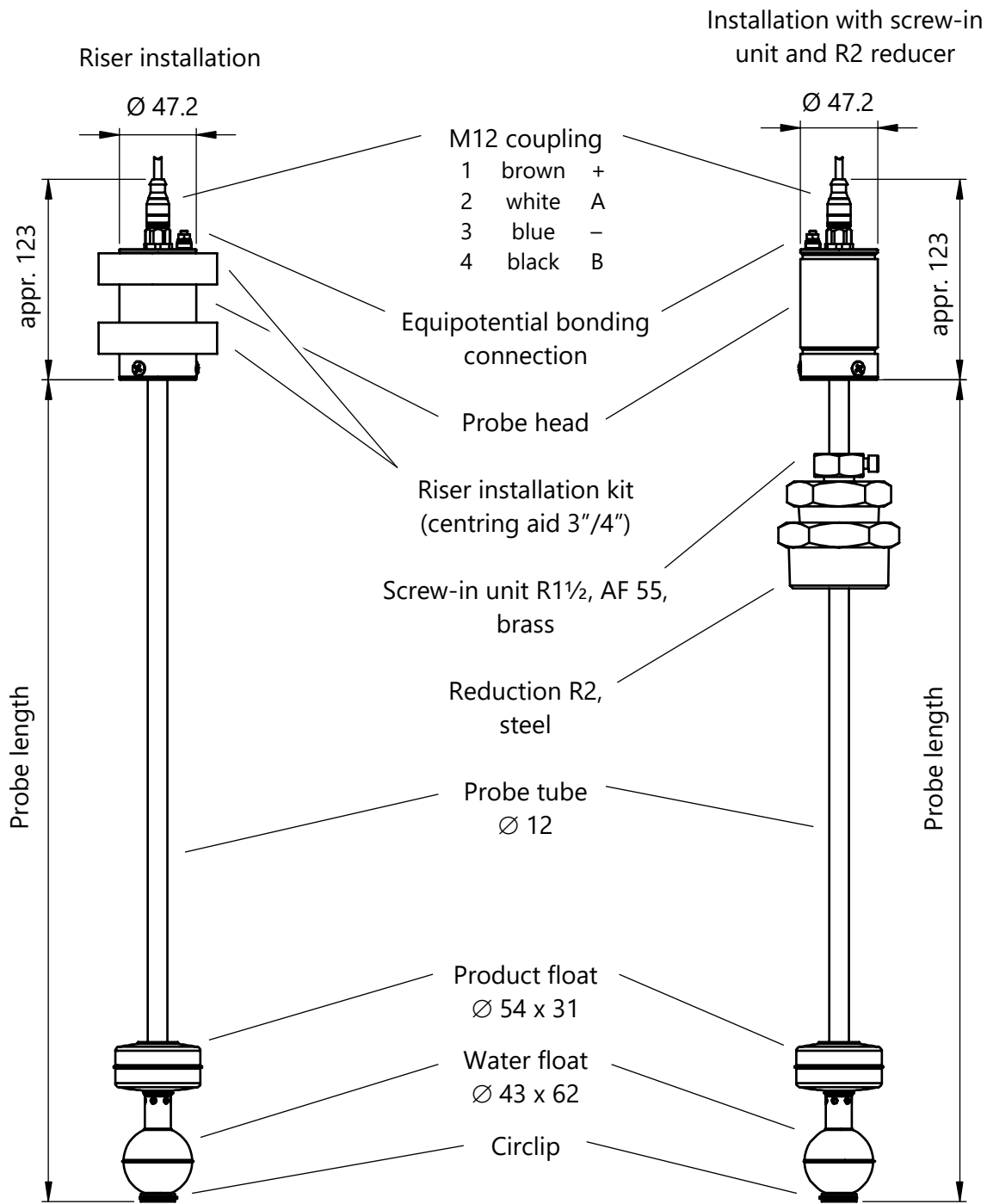

Figure 3: VISY-Stick Advanced

Dimensions in mm

3.3.3 VISY-Stick Ethanol

The sensor VISY-Stick Ethanol is designed for the level measurement of petrol-ethanol mixtures having an ethanol-content of more than 15 %. The sensor is available for riser installation and for installation with screw-in unit.

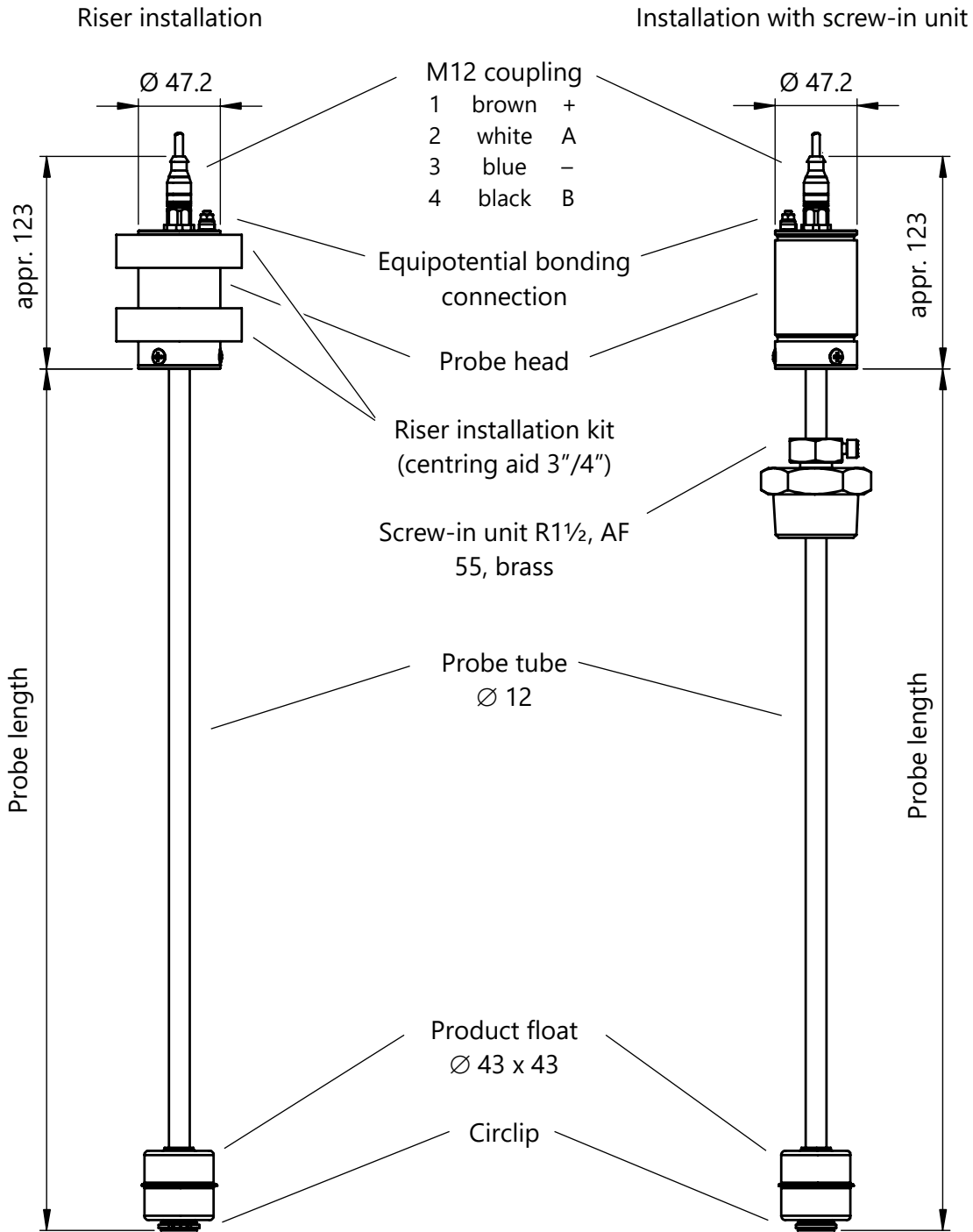

Figure 4: VISY-Stick Ethanol

Dimensions in mm

3.3.4 VISY-Stick Advanced Ethanol

The sensor VISY-Stick Advanced Ethanol is equipped with a higher measuring accuracy than VISY-Stick Ethanol. It is designed for the level measurement of petrol-ethanol mixtures having an ethanol-content of more than 15 %. The sensor is available for riser installation and for installation with screw-in unit.

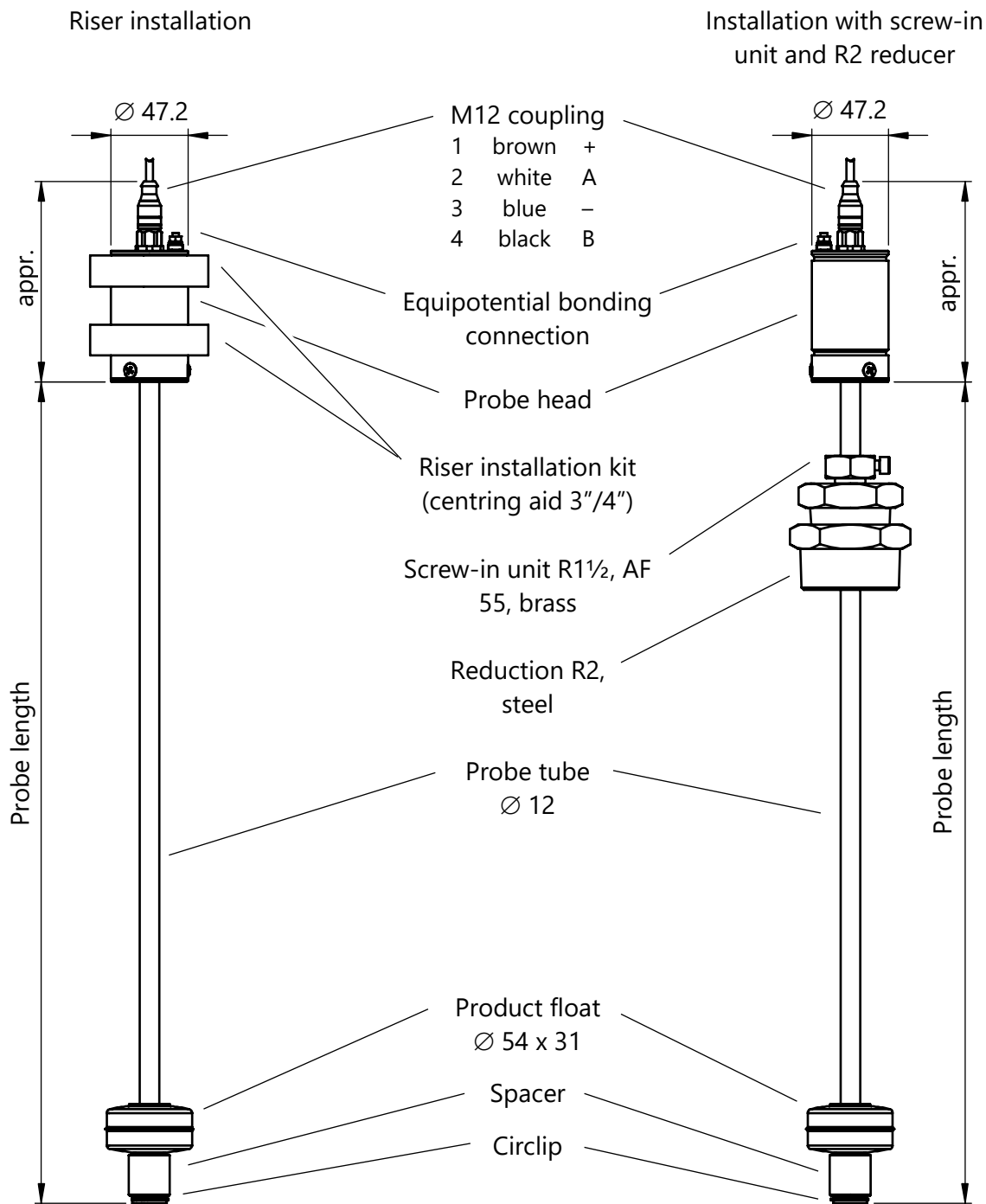

Figure 5: VISY-Stick Advanced Ethanol

Dimensions in mm

3.3.5 VISY-Stick N for AdBlue® Urea Solution

The sensor VISY-Stick N is designed for the level measurement of AdBlue®.

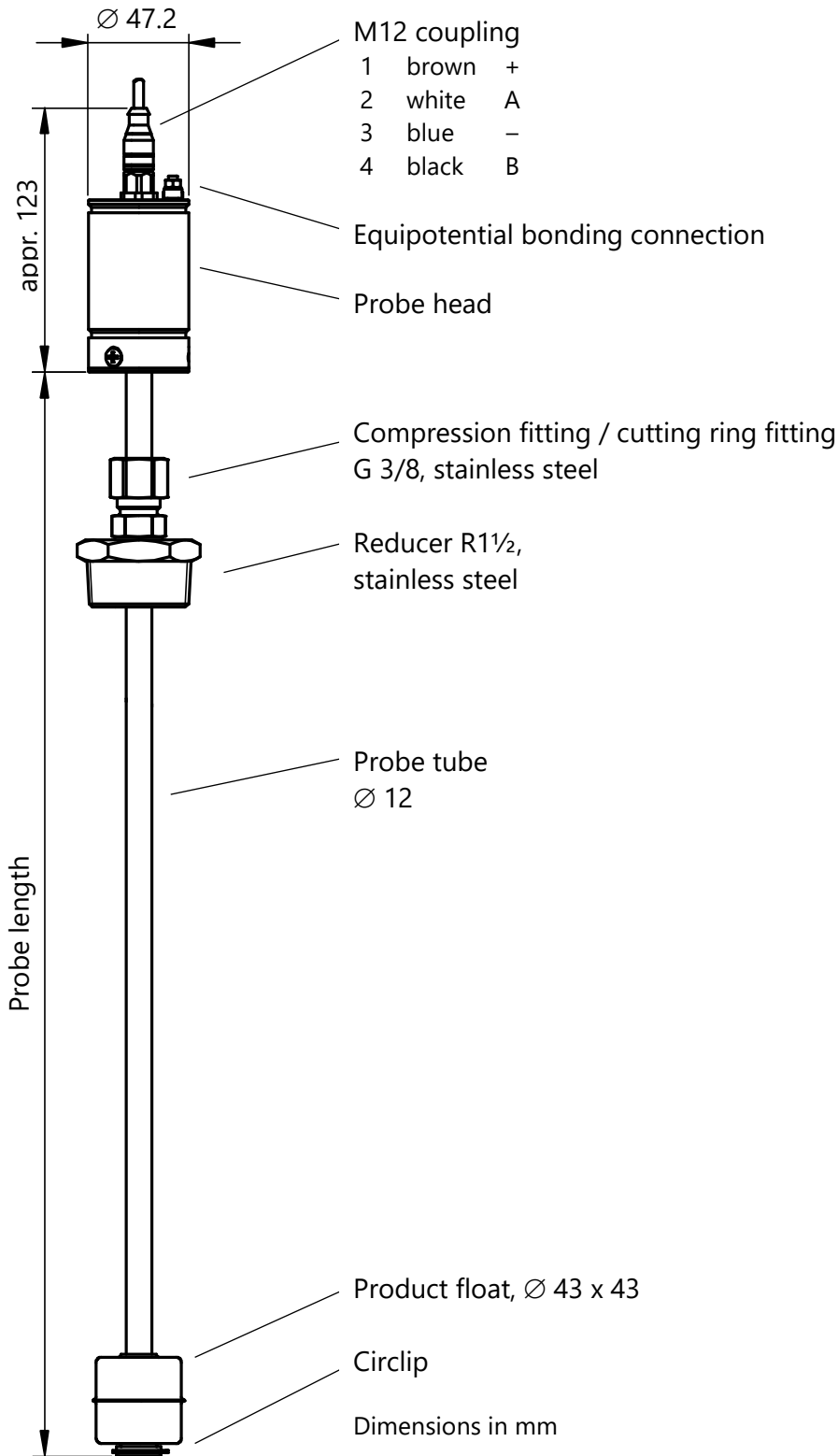

Figure 6: VISY-Stick N for AdBlue® urea solution

3.3.6 VISY-Stick Flex / Flex Biodiesel / Flex E15

The level sensor VISY-Stick Flex is a VISY-Stick with flexible probe tube. The magnetic base at the lower end of the probe tube keeps the sensor attached to the tank bottom after installation. The sensor installation is possible only with screw-in unit.

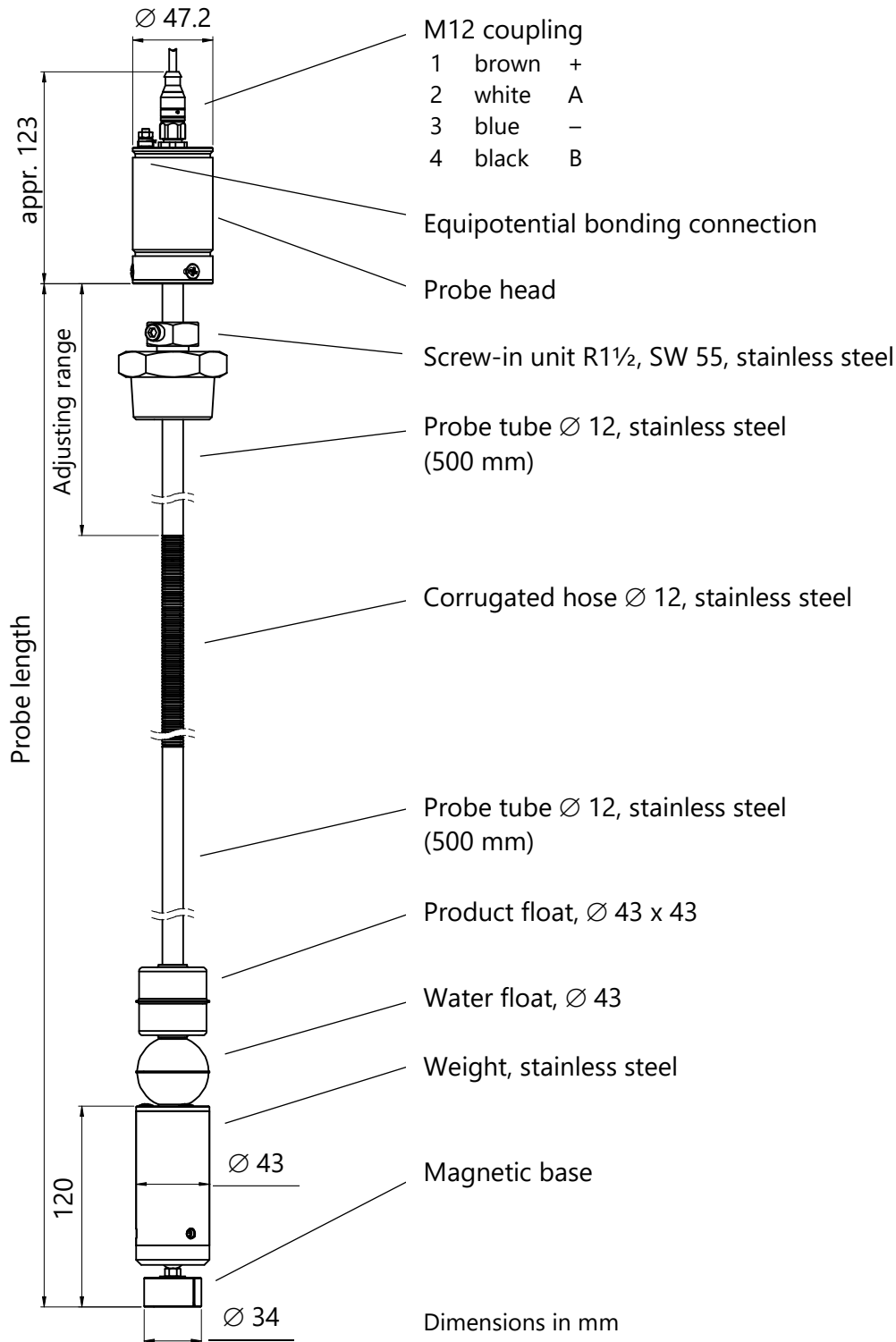

Figure 7: VISY-Stick Flex

3.3.7 VISY-Stick LPG

The sensor VISY-Stick LPG is designed for the level measurement of liquefied petroleum gas (LPG).

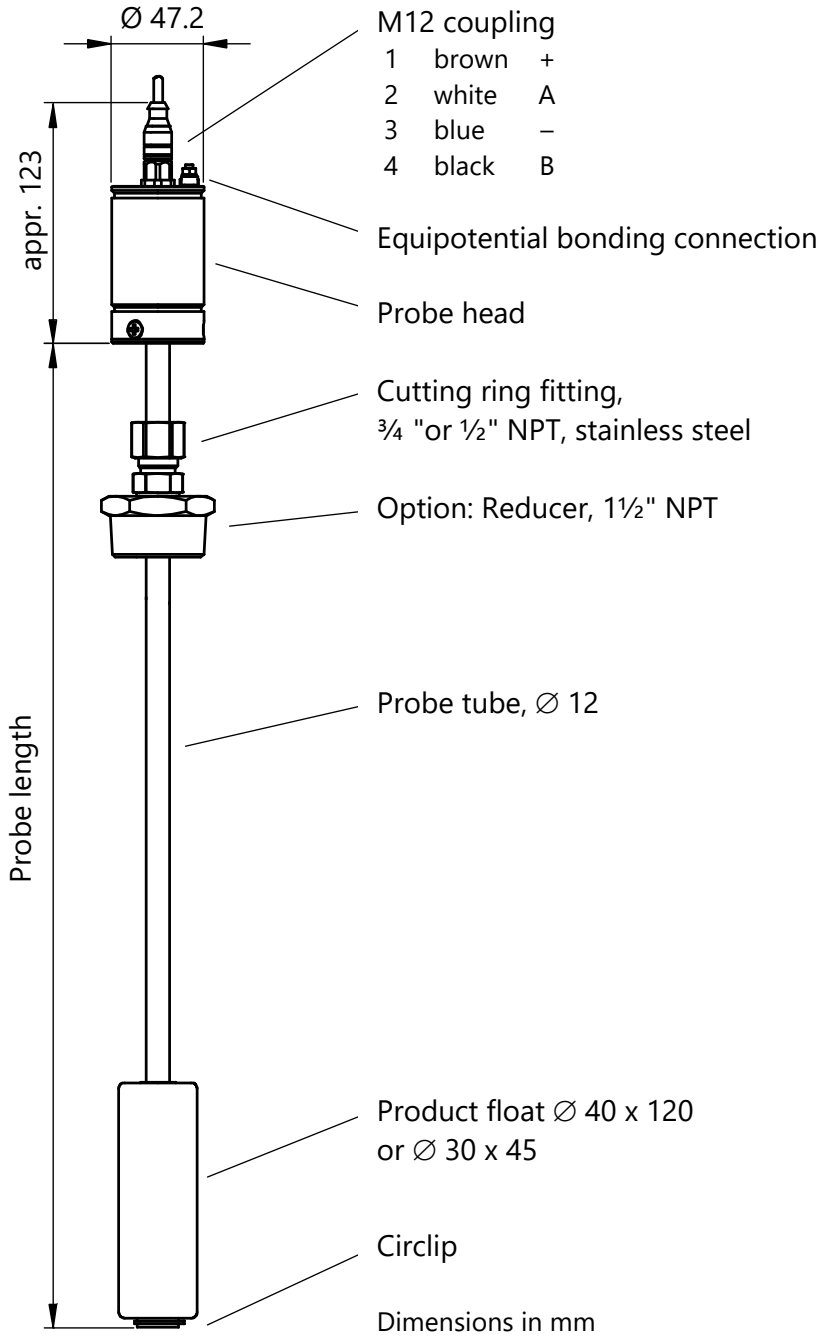

Figure 8: VISY-Stick LPG

3.3.8 VISY-Density (LPG) module



See Technical Documentation VISY-Density (LPG), Art. No. 350213

4 Environmental Sensors

The environmental sensors include the

- VISY-Stick Interstitial for the leakage detection of tanks
- VISY-Stick Sump for the detection of liquids in the manhole or in the dispenser sump with freely selectable alarm threshold
- VISY-Reed for the detection of liquids in the manhole or in the dispenser sump with a fixed alarm threshold
- VIMS sensors for leakage detection of tanks (VIMS tank), leakage detection of product lines to the fuel dispensers (VIMS product pipe) or leakage detection of filling lines to the tanks (VIMS delivery pipe)

The VISY-Stick sensors operate according to the magnetostrictive measurement principle (see chapter 3.1), the VISY-Reed sensors have a reed contact with switching function.

For more information on the VIMS sensors, please contact our system partner: SGB GmbH, Siegen, Germany, (see chapter 1.1).

4.1 Types

The following environmental sensors then are described:

- VISY-Stick Interstitial
- VISY-Reed Interstitial Dry
- VISY-Stick Sump Manhole / Sump Dispenser
- VISY-Reed Sump Manhole / Sump Dispenser
- VISY-Stick Oil

4.1.1 VISY-Stick Interstitial

The sensor VISY-Stick Interstitial is designed for monitoring the leak-detection fluid (salt brine, glycol, etc.) in the intermediate chambers of double-walled tanks. It reports over- and under-shooting of adjustable thresholds. VISY-Stick Interstitial can be used as a "dry sensor" which detects the penetration of a liquid into the intermediate chambers of double-walled tanks. The sensor is available for riser installation and for installation with screw-in unit.

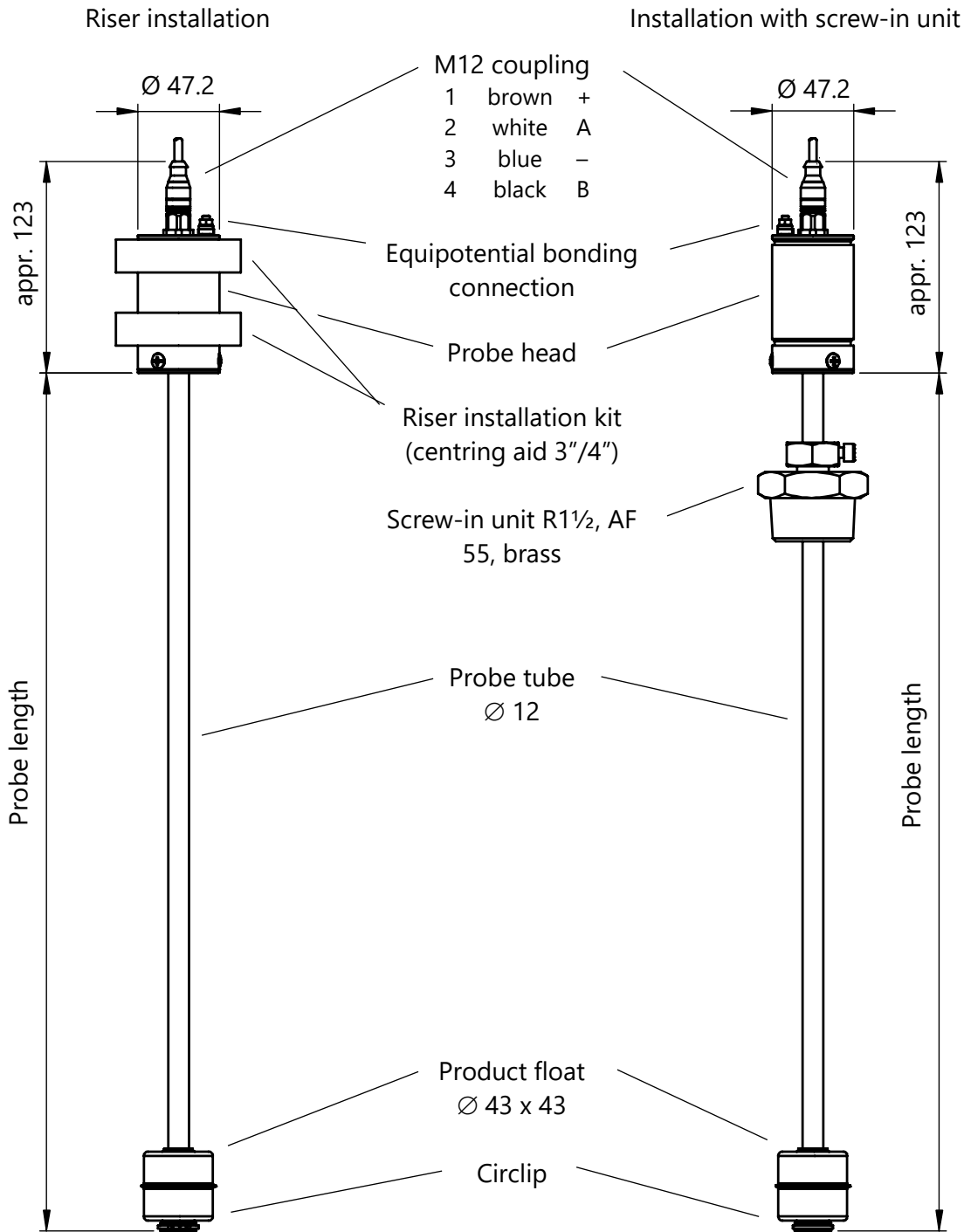

Figure 9: VISY-Stick Interstitial

Dimensions in mm

4.1.2 VISY-Reed Interstitial Dry

The sensor VISY-Reed Interstitial Dry is designed for monitoring dry intermediate chambers of double-walled tanks. The reed contact indicates the penetration of a liquid into the dry space.

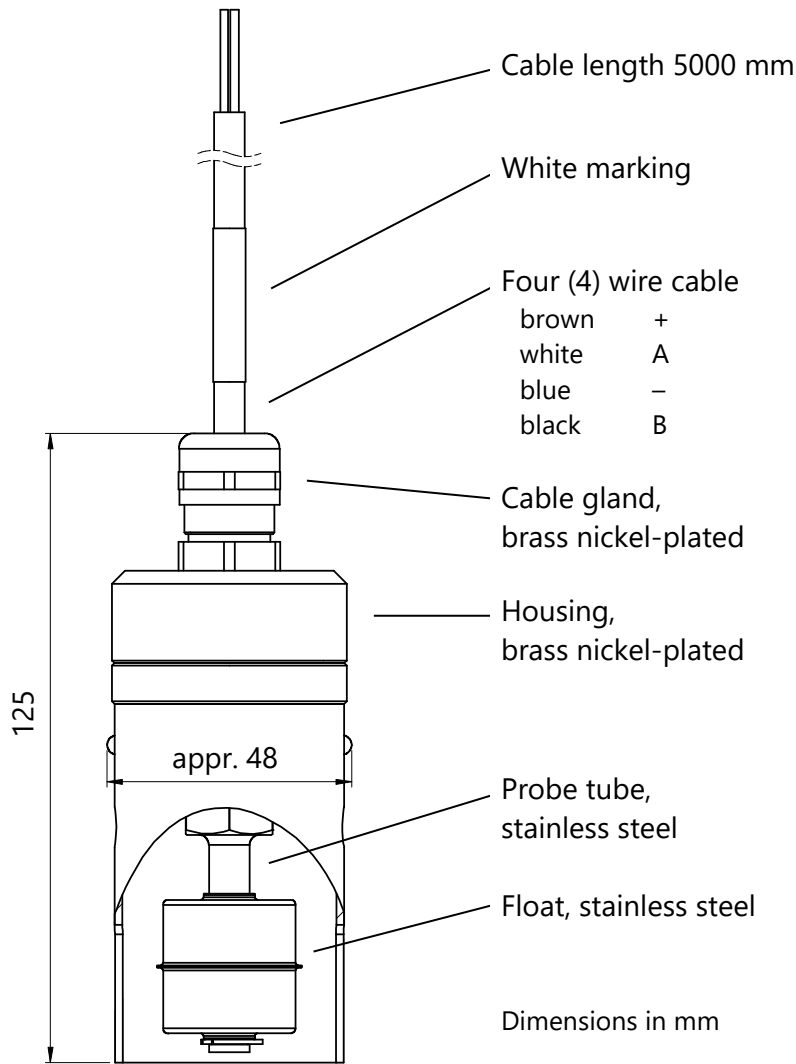

Figure 10: VISY-Reed Interstitial Dry

4.1.3 VISY-Stick Sump Manhole / Dispenser

The sensor VISY-Stick Sump is designed for monitoring the manhole (Manhole version) and the sump underneath the dispenser (Dispenser version). The sensor detects fluids that could potentially accumulate in the sump and is capable to distinguish between water and fuel. The sensor is tamper-proofed. For the mounting an installation kit is available (art. no. 910036).

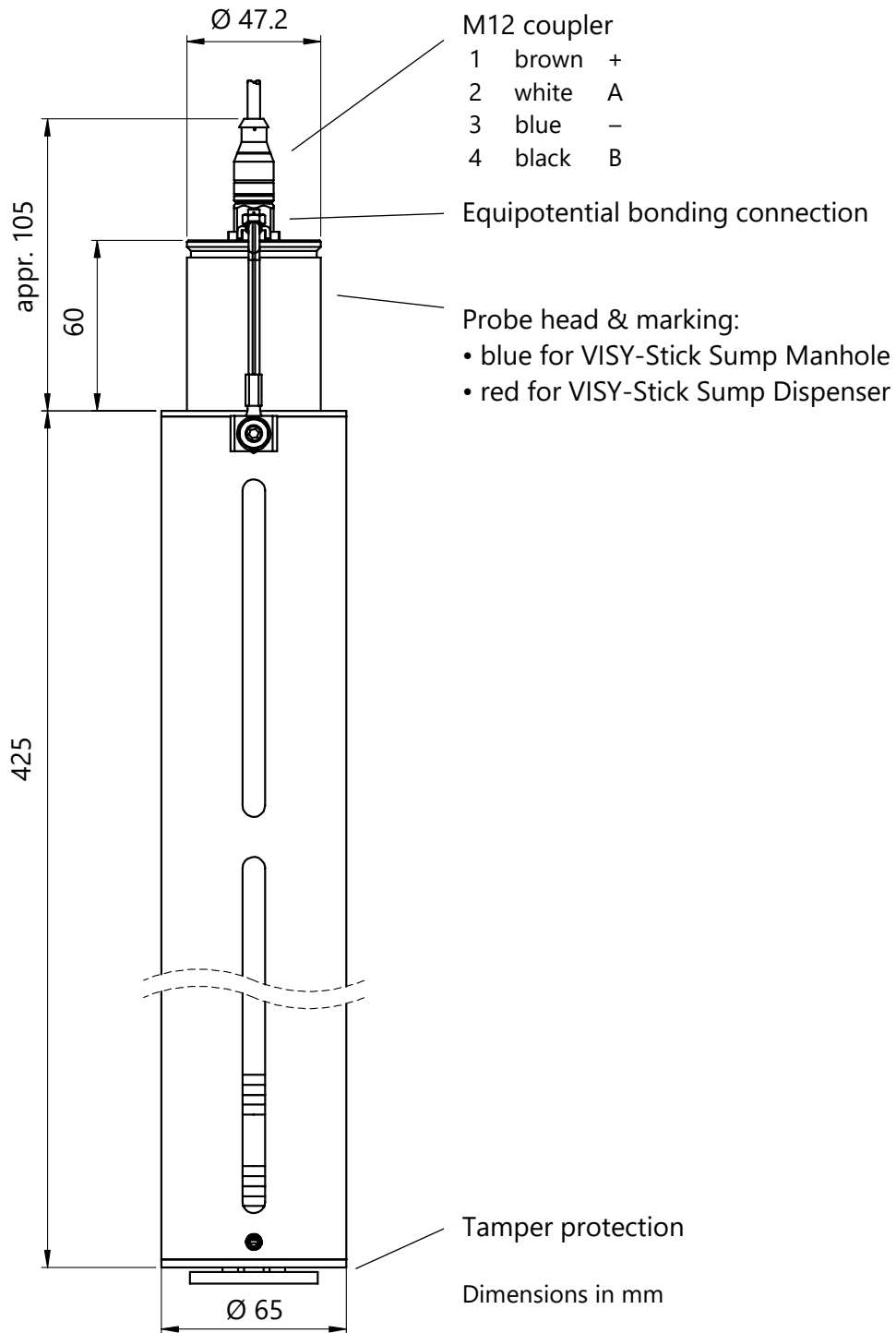

Figure 11: VISY-Stick Sump

4.1.4 VISY-Reed Sump Manhole / Dispenser

The sensor VISY-Reed Sump is designed for monitoring the manhole (Manhole version) and the sump underneath the dispenser (Dispenser version) if distinction of liquids is not required. The sensor detects liquids that may accumulate in the sumps. The float switch is used as a pure alarm switch.

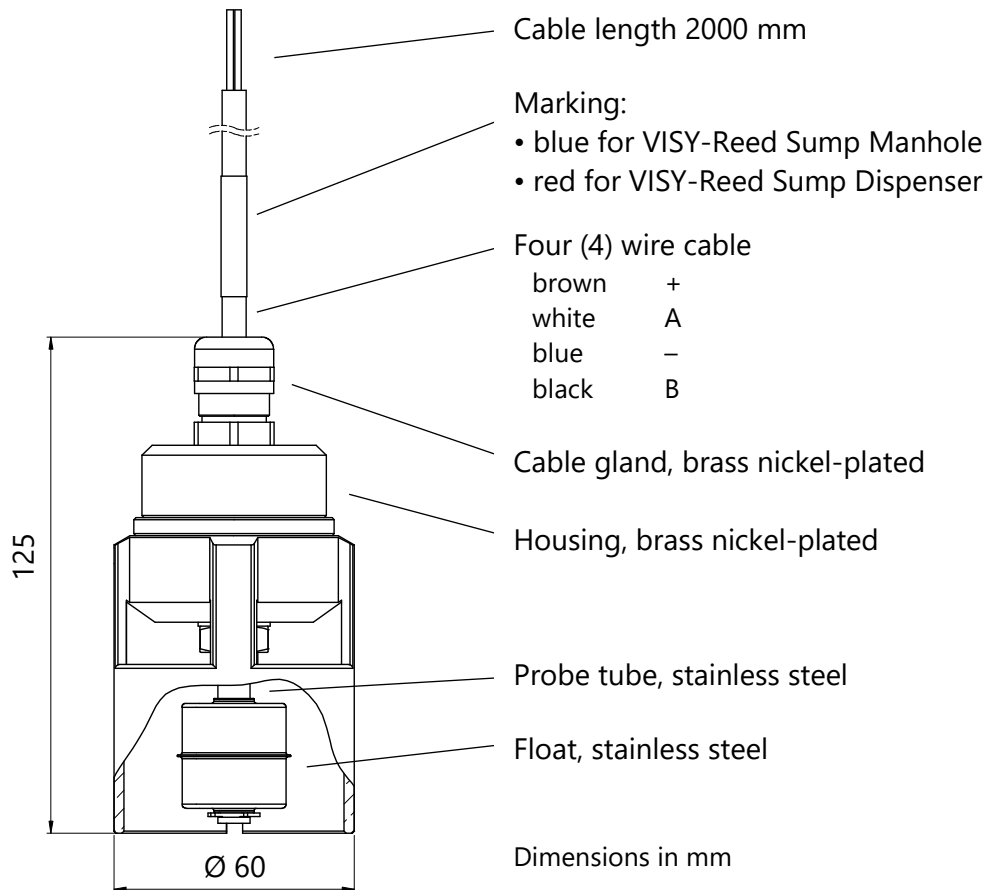

Figure 12: VISY-Reed Sump

4.1.5 VISY-Stick Oil

The sensor VISY-Stick Oil is suitable for monitoring the oil layer in oil separators. The sensor continuously detects the height of the light-liquid layer and gives an alarm when a configurable threshold is reached.

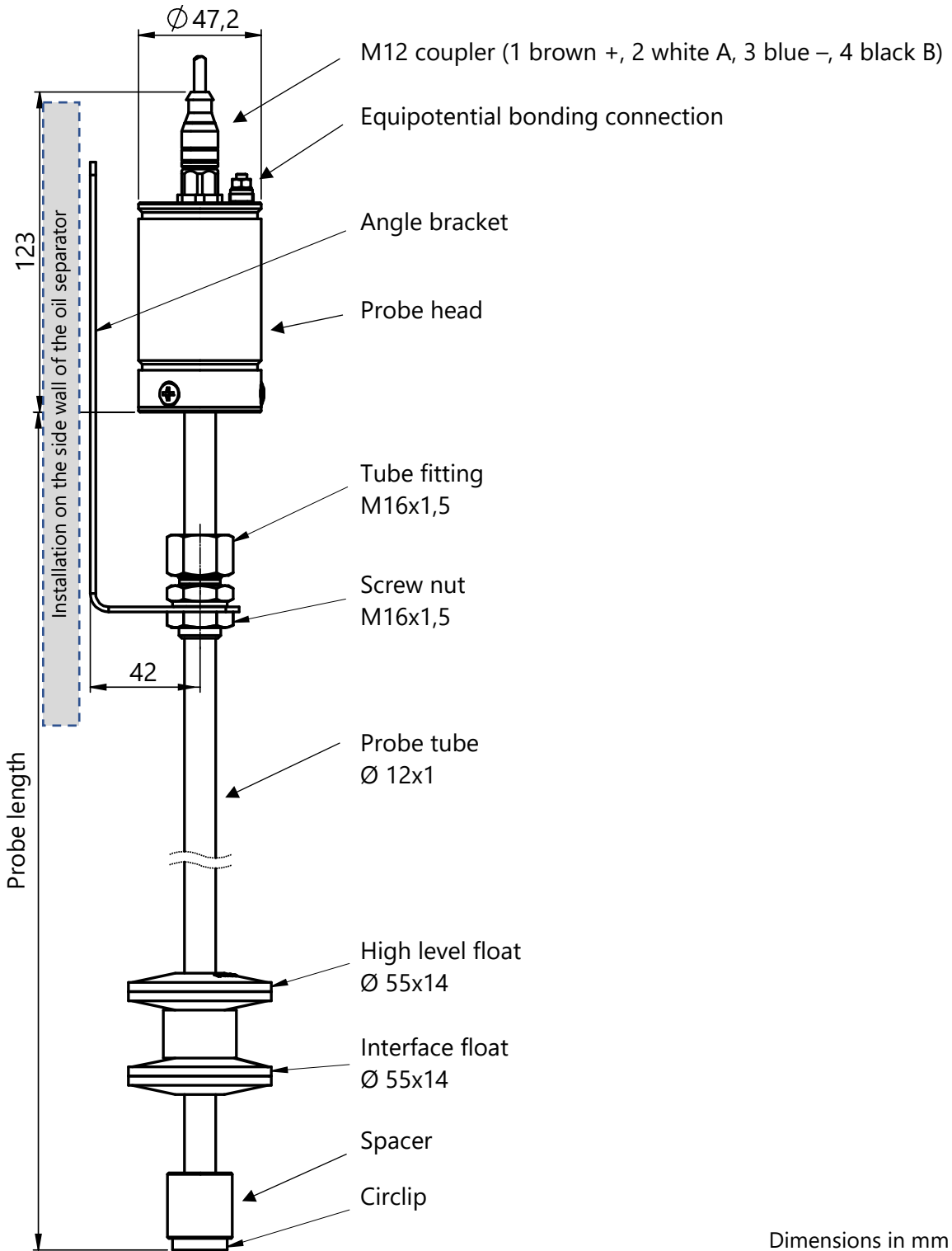

Figure 13: VISY-Stick Oil

5 Installation

5.1 Installation and Safety Instructions



For the installation and maintenance of the sensors, the requirements of the Explosion Protection Regulations, the Industrial Health and Safety Regulations and the Equipment Safety Regulations as well as generally accepted rules of engineering and this manual must be observed.



All applicable local safety and accident prevention regulations not included in this manual must also be observed.



During the assembly, it is important to make sure that the probe tube is not bent. Protect the floats from knocks at all times. No moisture may enter the M12 connector.



Before installation move the supplied floats to the bottom end of the probe tube, otherwise they will slip down suddenly when you erect the sensors and could be damaged when striking the circlip.



During the installation, following data of the VISY-Stick sensors, tanks, and products are to be noted for configuring the VISY-Command:

- Device numbers of the sensors,
- Tank assignments of the sensors,
- Tank assignments of the products,
- Terminal connection of the sensors in the VISY-Command,
- Sensor distances from the central vertical axes of the tanks (see Chapter 5.4)



For identification purposes, the probe heads of the various model types are wrapped in a coloured net, which must be removed prior to installation. The probes are associated with the following colours:

<i>VISY-Stick N for AdBlue®:</i>	<i>blue</i>
<i>VISY-Stick Interstitial:</i>	<i>brown</i>
<i>VISY-Stick LPG:</i>	<i>yellow</i>
<i>VISY-Stick Biodiesel:</i>	<i>green</i>
<i>VISY-Stick Ethanol (> 15%):</i>	<i>orange</i>
<i>VISY-Stick E15 (0-15 %):</i>	<i>white</i>
<i>VISY-Stick / Advanced / Flex / VISY-Reed / VISY-Sump</i>	<i>without net</i>

5.2 Variants

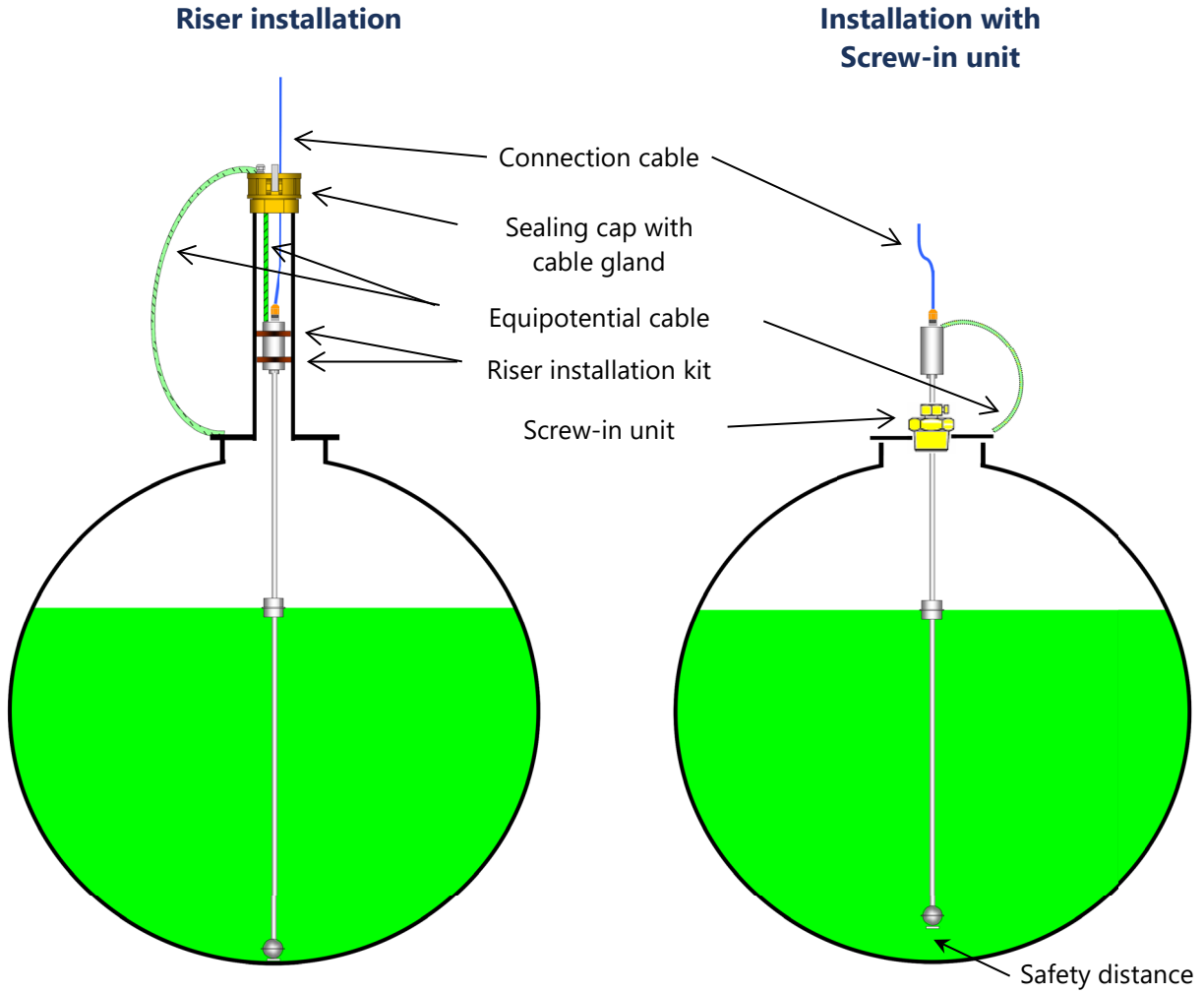

Figure 14: VISY-Stick installation with riser and screw-in unit

5.2.1 Installation with screw-in Unit

For installation of the VISY-Stick sensor, the tank coupling must have an internal thread of at least 1½"; for the VISY-Stick Advanced sensor, it must have an internal thread of at least 2".

The procedure for installing sensors with screw-in unit (see Figure 14) is described below. For tank pipe couplings with an internal thread larger than 1½", reducers of the appropriate size will also be required:

- (1) Check that the circlip on the end of the probe tube is securely attached so that the float is unable to fall into the tank.
- (2) The floats must be pushed onto the probe tube with the marking "TOP" facing the probe head.
- (3) Use a hexagon socket key (5 mm) to loosen the locking screw and stuffing box (SW 30) so that the screw-in unit can be moved easily on the probe tube.
- (4) Provide the screw-in unit with suitable sealing material and then screw it into the tank coupling together with the VISY-Stick.
- (5) Press the probe tube gently onto the bottom of the tank and then lift it again to incorporate an appropriate safety distance. To fix the probe tube, first tighten the stuffing box and then tighten the locking screw.



If there is no safety distance between the probe tube and the bottom of the tank, the tube could be bent and damaged by the tightening process. For tanks with a diameter up to 2900 mm, the safety distance must be about 10 mm. For larger tanks, the safety distance must be more than 10 mm, and is to be selected according to the tank size.



Write down this safety distance for the configuration of VISY-Command with VISY-Setup.

- (6) Connect the equipotential bonding cable with the outer equipotential clamp of the probe head.
- (7) Connect the supplied FAFNIR connection cable to the VISY-Stick. First tighten the union nut of the M12 coupler by hand and then tighten it further through 180° using a spanner. The tightening torque should be between 100 ... 150 Ncm.

An installation kit 1" is also available as an option. This installation kit consists of a product- and water float and a screw-in unit. It makes the installation of VISY-Stick possible by using an R1 threaded sleeve.

5.2.2 Riser Installation

The usual riser installation is made with 3" or 4" pipes (the diameter of the pipes must be at least 2" for drawn pipes or 2.5" for welded pipes). The VISY-Stick for risers (see Figure 14) is installed as follows:

- (1) As shown in the figure below, pull the riser installation kit (art. no. 900111) over the probe head and adjust it to 3 or 4 inches depending on the riser diameter.

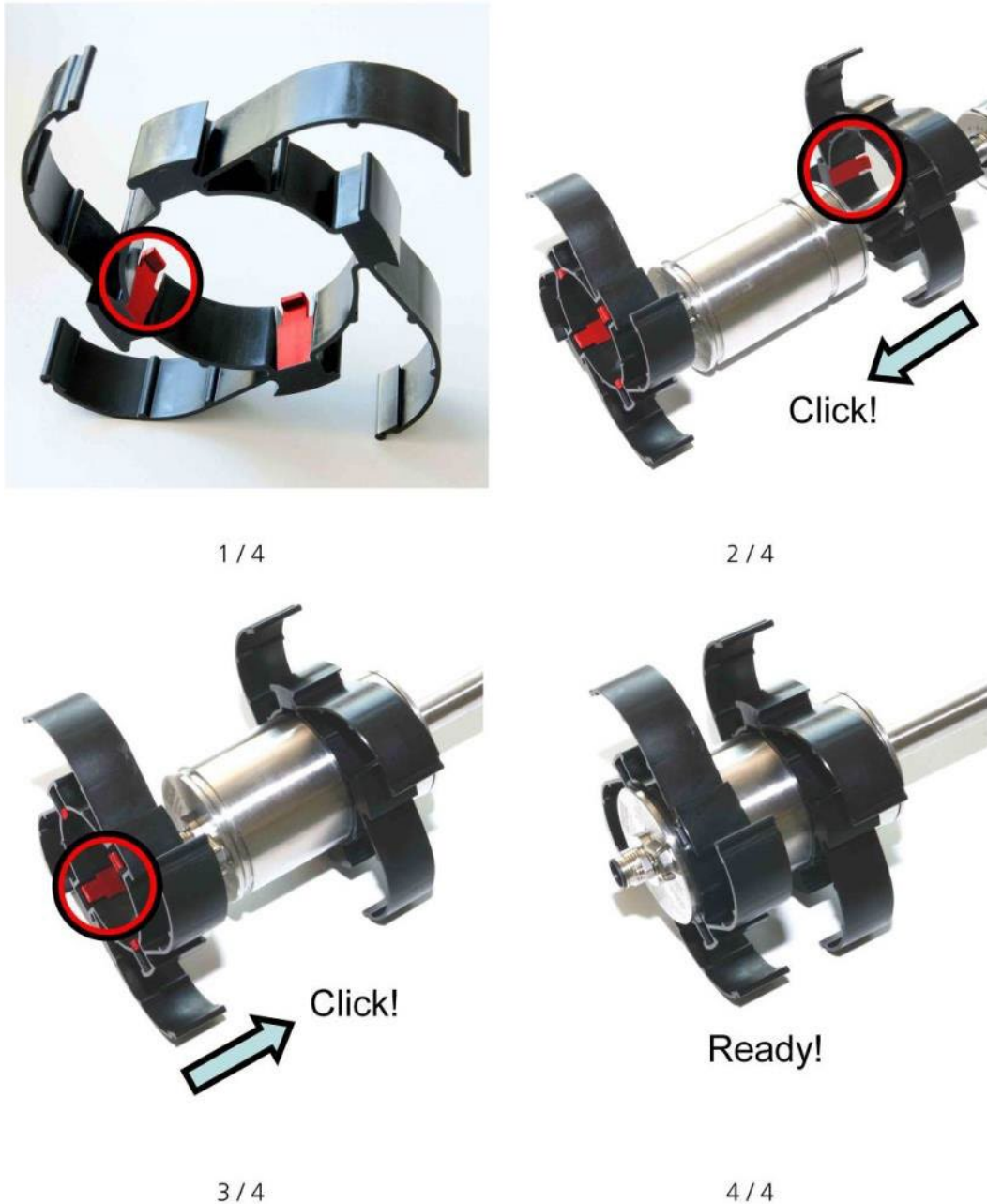

Figure 15: Riser installation kit

- (2) Check that the circlip on the end of the probe is securely attached so that the float is unable to fall into the tank.

- (3) The floats must be pushed onto the probe tube with the marking "TOP" facing the probe head.
- (4) Connect the equipotential cable with the outer equipotential clamp of the probe head.
- (5) Connect the supplied FAFNIR connection cable to the VISY-Stick. First tighten the union nut of the M12 coupler by hand and then tighten it further through 180° using a spanner. The tightening torque should be between 100 ... 150 Ncm.
- (6) Let the VISY-Stick sensor slowly slide into the riser and place carefully on the bottom of the tank.
- (7) Install a suitable cable gland in the sealing cap of the riser and guide the FAFNIR connection cable and the equipotential cable through it.

If the riser protrudes into the tank, a coaxial arrangement must be employed inside the pipe during installation of the VISY-Stick level sensor. The float must be able to move freely without touching the riser.

5.2.3 Installing VISY-Stick N and VISY-Stick LPG without Installation Kit

Similar to chapter 5.2.1, but the cutting ring screw is tightened.

5.2.4 Installation of VISY-Stick Flex



Please note that the flexible and therefore fragile nature of the VISY-Stick Flex sensor makes it more prone to mechanical shock. The sensor must not be unpacked until it has been brought to its place of installation.



The corrugated hose must not be bent more than it already is in the packaging and must not be pulled apart in axial direction.



Installation must be carried out by at least two persons, one of whom unrolls the corrugated hose while the other feeds the corrugated hose into the tank.

For sensor installation, the tank coupling provided for assembly must have an internal thread of 1½". The sensor is supplied in a special transport box. The float and the weight are ready assembled. Before installation, prepare a spanner (AF 55) and some sealing material for the screw-in unit, a hexagon key (5 mm), a spanner (AF 30) for the stuffing box, and a measuring instrument.

- (1) Remove the sensor from the packaging
- (2) If there is deformation or kinking at the transition between probe tube and corrugated hose, this must be straightened out with extreme care
- (3) Loosen the hexagon-socket screw and stuffing box, slide the screw-in unit towards the probe head and secure, then seal in the thread of the screw-in unit
- (4) Slide the float onto the weight at the lower end of the probe
- (5) Feed the lower end of the probe (magnetic base) into the tank
- (6) Unroll the corrugated hose, taking care to avoid chafing on the tank coupling, until the top end of the corrugated hose reaches the tank coupling
- (7) Then lower the sensor slowly until you feel the magnetic force of the magnetic base take hold on the tank bottom (steel tanks only)
- (8) In this position, measure the clearance from the lower edge of the probe head to the tank lid (installation dimension) and note it down
- (9) Lower the probe head slightly, slide the screw-in unit towards the tank coupling and tighten
- (10) Raise the probe head until the exact installation dimension that you measured before. Attention: do not raise it any higher, otherwise the sensor will become detached from the tank bottom
- (11) Tighten the stuffing box and secure using the hexagon-socket screw
- (12) Then connect the M12 coupler of the supplied FAFNIR connection cable to the sensor and connect the cable to the VISY-Command (optionally to the transmitter VISY-RFT of the radio version)
- (13) Configure VISY-Command using the VISY-Setup software, set the water alarm to a value higher than 150 mm and enter the distance between the end of the holding magnet and the bottom of the tank as the offset, see chapter 5.4
- (14) Compare the displayed filling level with the actual filling level, if known (plausibility check)

5.2.5 Sensor Replacement Instructions

After replacing the VISY-Stick sensor, the following values must be entered again using VISY-Setup:

- The device number of the new VISY-Stick sensor
- Check the installation offset value and correct as necessary

5.2.6 Installation Kit for VISY-Stick Sump

An installation kit (art. no. 910036) is available for mounting the VISY-Stick Sump.

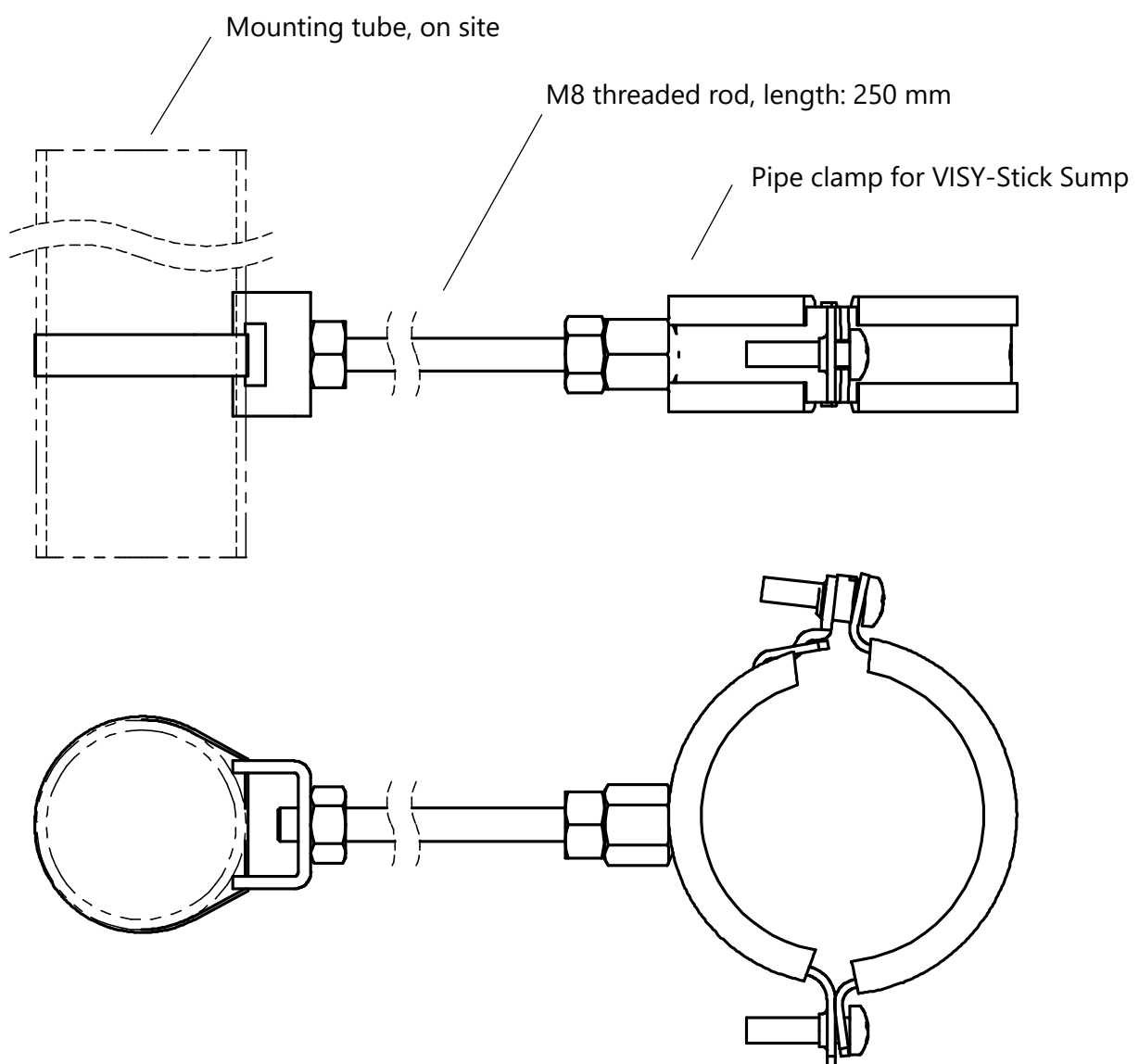

Figure 16: Installation kit for VISY-Stick Sump

5.2.7 Variable LPG Installation Kit for Liquid Gas Containers

The Variable LPG Installation Kit has been developed for FAFNIR sensors to measure the level in LPG tanks without having to mount the sensor directly in the tank. This allows to install and to remove the sensor without having to open the tank every time.

The Variable LPG Installation Kit consists of a jacketed pipe with an LPG float (BUNA), a compression/ cutting ring fitting (non-detachable) with 3/4" NPT external thread for process connection, and a reducer with PTFE clamping ring fitting (detachable) for fixing the VISY-Stick LPG sensor (see figure below).

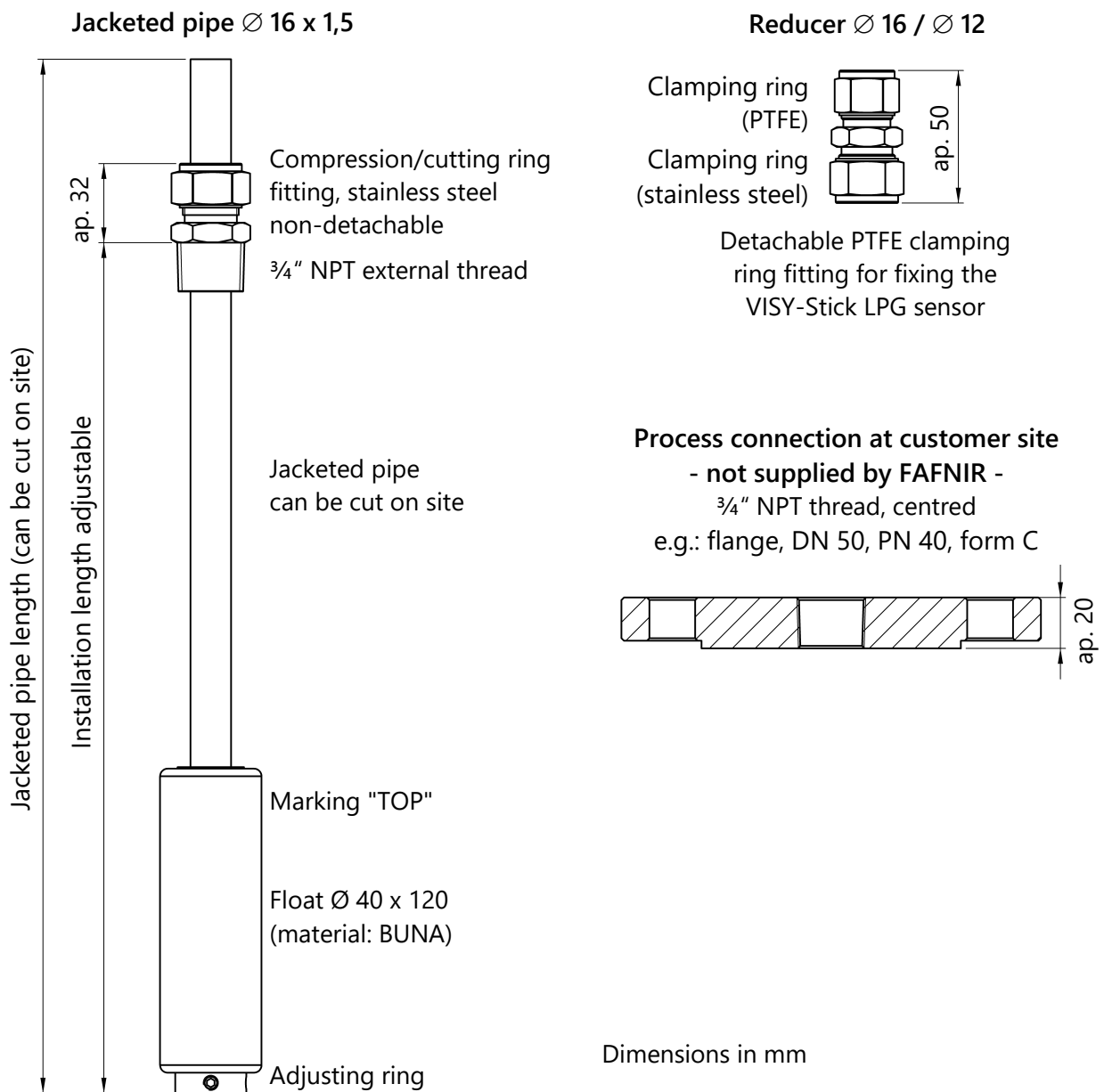

Figure 17: Variable LPG installation kit for liquid gas containers

- (1) The sensor must be able to stand on the bottom of the jacketed pipe (jacketed pipe and reducer must be shorter than the probe tube), cut the jacketed pipe if necessary.
- (2) Screw the sealed cutting ring fitting in the flange (min. DN 50) or reducer (min. 1 ½"), slide the jacketed pipe without the adjusting ring in the cutting ring fitting, the jacketed pipe must be easy to move.
- (3) Slide the float with marking "TOP" upwards the probe head on the jacketed pipe and fix the adjusting ring at the bottom of the jacketed pipe to prevent the float from falling into the tank. Move the float to the bottom of the jacketed pipe.



The marking "TOP" on the float must point towards the probe head.

- (4) Screw the flange or the reducer to the process connection of the tank.
- (5) Press down the jacketed pipe gently in the tank until it touches the bottom of the tank. Mark this 1st position on the pipe (1st marking), see figure below.
- (6) Move up the jacketed pipe for 10 mm (safety distance to the tank bottom). Mark this 2nd position on the pipe (2nd marking under 1st marking), see figure below.



If there is no safety distance between the jacketed pipe and the bottom of the tank, the pipe can be bent and damaged during the installation process.

- (7) Fix the jacketed pipe with the cutting ring fitting at the 2nd marking first hand-tighten and then with a 1 ¼ clockwise turn (see following figure).

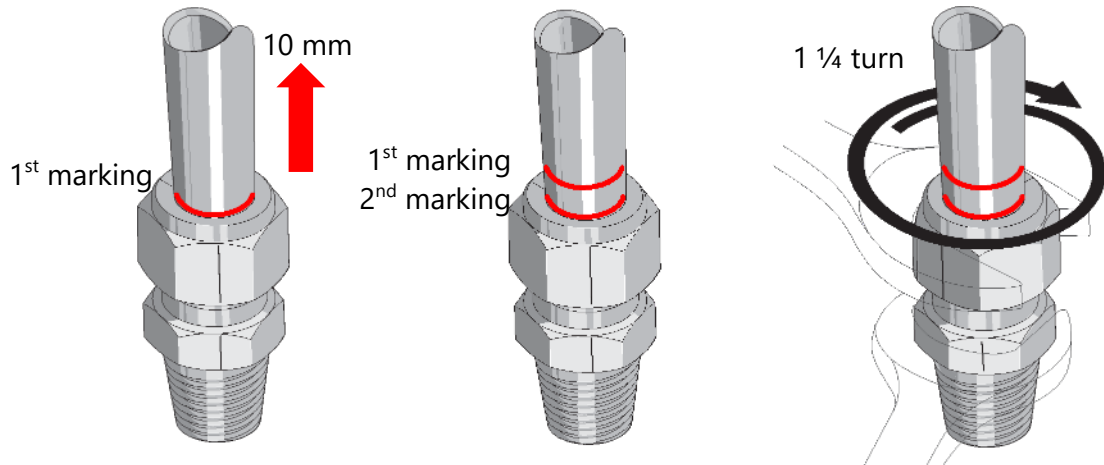

After fixing, the cutting ring fitting can no longer be dismantled.

- (8) Put the reducer Ø 16 / Ø 12 on the jacketed pipe and fix it.
- (9) Press down the VISY-Stick LPG sensor without float gently in the reducer until it touches the bottom of the jacketed pipe. Tighten it with the PTFE-clamping ring fitting.
- (10) Configure the VISY-Command: 18 mm must be entered as an offset in VISY-Setup (safety distance 10 mm + jacketed pipe bottom 8 mm) and LPG as product quality.



See also: Variable LPG Installation Kit, installation instructions, art. no. 350094

5.2.8 1" Installation Kit

The optional 1" Installation kit (art. no. 908493 for E10, art. no. 908484 for DK, art. no. 900168 for E85) allows the installation of the VISY-Stick by means of a R1 threaded sleeve.

 *The 1" installation kit is not suitable for biodiesel.*

The installation kit consists of a 1" screw-in unit, a 1" product float and a 1" water float. A stainless-steel version of the screw-in unit is available as an option.

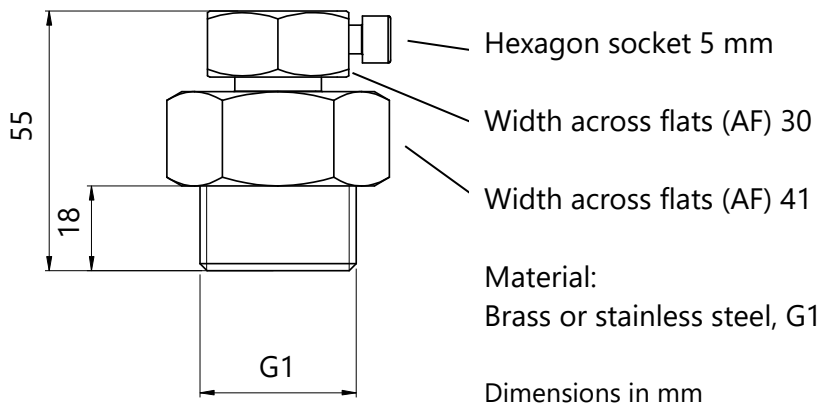

Figure 18: 1" screw-in unit

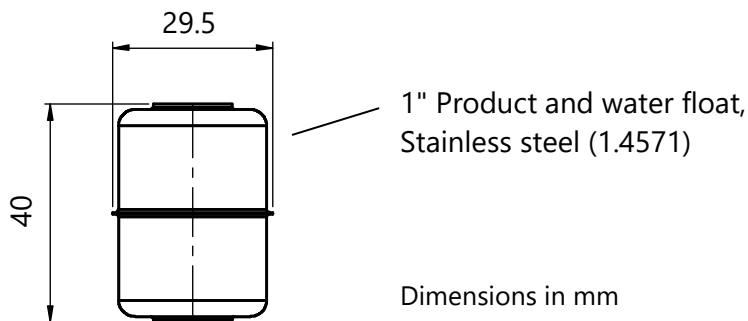

Figure 19: 1" Product and water float

5.3 Electrical Connection

Always ensure that the power has been disconnected before you wire up the VISY-Stick sensors to the VISY-Command central unit. For wiring, proceed as follows:

- If not already connected, plug the M12 coupler of the supplied FAFNIR connection cable onto the M12 connector of the probe head. First tighten the union nut of the coupling by hand and then tighten the nut further through 180° using an open-ended spanner. The tightening torque should be between 100 ... 150 Ncm.

- Connect the routed cable (originating from VISY-Command) to the FAFNIR connection cable, e.g. using an installation sleeve (art. no. 910035) with pin assignment as follows:

brown	+	Pin 1
white	A	Pin 2
blue	-	Pin 3
black	B	Pin 4

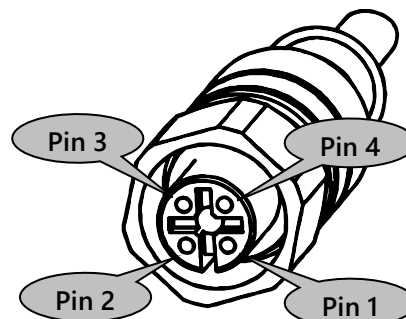

Table 1: Assignment of the M12 coupler

The connection cable between the VISY-Stick and VISY-Command must have the following properties:

- Four-wire unshielded cable, oil-resistant
- Cable cross-section (4 x 0.5 mm² up to 200 m)
- Colour blue or marked blue (cable for intrinsically safe power circuits)
- Maximum diameter 6 - 10 mm for reliable sealing by the cable gland in VISY-Command.



The equipotential bonding must be carried out by the installer in accordance with the nationally applicable installation regulations. For this purpose the equipotential terminal of the probe head can be used.

5.3.1 Voltage Surge Protection

To protect the VISY-Stick level sensors from voltage surges, we recommend that you install the BA 350 DUO voltage surge protector directly upstream of the probe in the manhole or dispenser sump. The BA 350 DUO voltage surge protector is installed between the FAFNIR connection cable of the probe and the VISY-Command cable installed on site (art. No. 903314).



Special EN regulations including EN 60079-14 and EN 60079-25 as well as local installation regulations must be observed.

5.4 Installation Offset

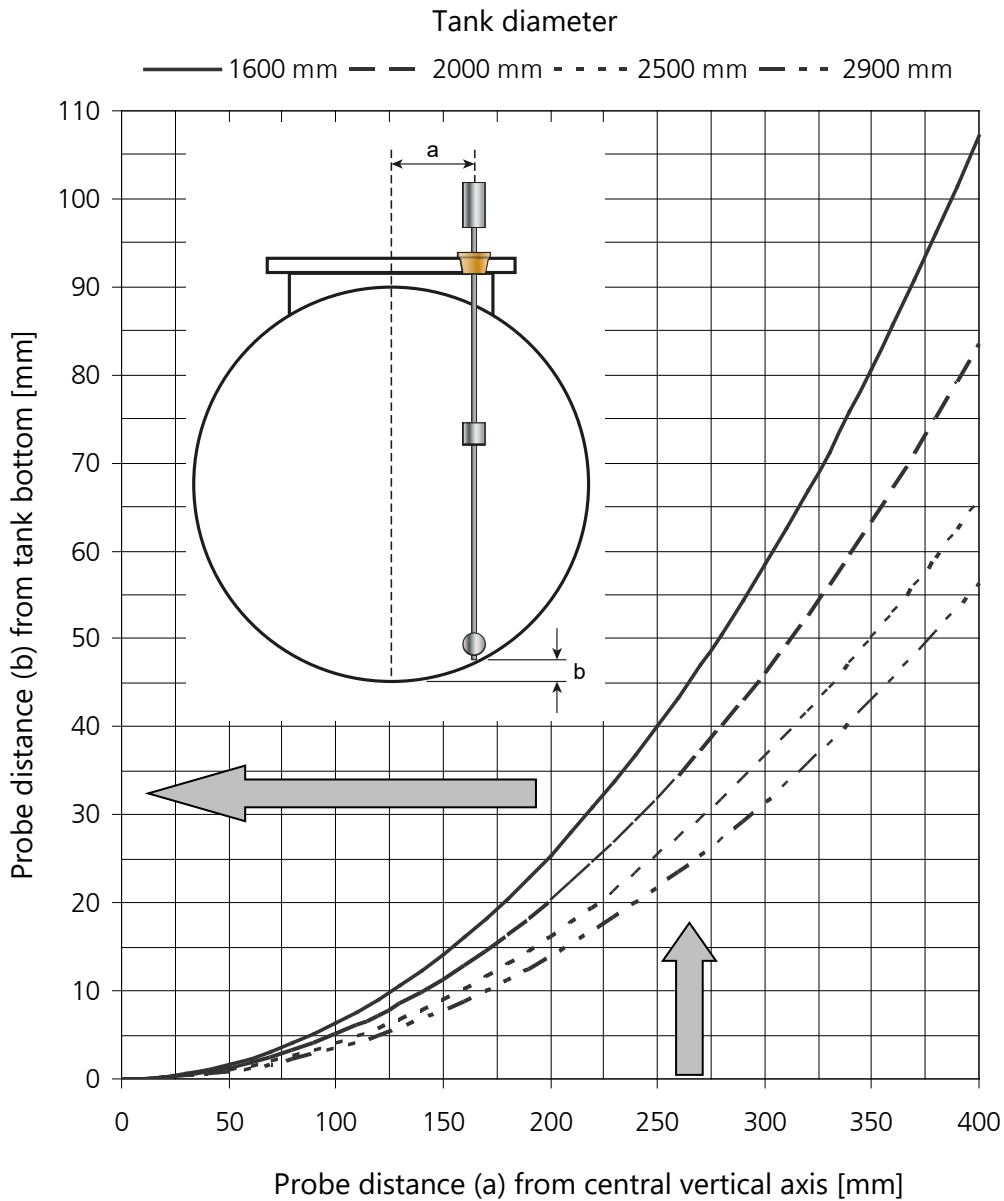

Figure 20: Installation offset

The VISY-Stick sensors are installed vertically in the tanks as close as possible to the central vertical axis. Afterwards, it will be necessary to configure the respective positions of the sensors in VISY-Command using the installation offset. The offset is composed of the distance (b) of the probe tube (see Figure 20) to the tank bottom plus the safety distance (see Figure 14). The installation offset is transmitted to VISY-Command during configuration of the individual measuring points using the VISY-Setup software application.

Figure 20 shows the probe distance (b) from the lowest point of the tank bottom for cylindrical tanks according to DIN 6608, 6616, 6617, and 6624 depending on probe distance (a) from the central vertical axis when the probe is in contact with the tank wall.

6 Maintenance

6.1 Servicing

The sensors and associated floats are maintenance-free if they are operated according to the manufacturer's specifications and not used to measure other media.

6.2 Return Shipment

Before returning any FAFNIR equipment the Return Material Authorization (RMA) by the FAFNIR customer support is required. Please contact your account manager or the customer service to receive the instructions on how to return goods.



The return of FAFNIR equipment is possible only with authorization by the FAFNIR customer care.

7 List of Figures

Figure 1: Mode of operation of the magnetostrictive measuring principle.....	5
Figure 2: VISY-Stick / Biodiesel / E15.....	7
Figure 3: VISY-Stick Advanced.....	8
Figure 4: VISY-Stick Ethanol.....	9
Figure 5: VISY-Stick Advanced Ethanol.....	10
Figure 6: VISY-Stick N for AdBlue® urea solution.....	11
Figure 7: VISY-Stick Flex.....	12
Figure 8: VISY-Stick LPG.....	13
Figure 9: VISY-Stick Interstitial.....	15
Figure 10: VISY-Reed Interstitial Dry.....	16
Figure 11: VISY-Stick Sump.....	17
Figure 12: VISY-Reed Sump.....	18
Figure 13: VISY-Stick Oil.....	19
Figure 14: VISY-Stick installation with riser and screw-in unit.....	21
Figure 15: Riser installation kit.....	23
Figure 16: Installation kit for VISY-Stick Sump.....	26
Figure 17: Variable LPG installation kit for liquid gas containers.....	27
Figure 18: 1" screw-in unit.....	29
Figure 19: 1" Product and water float.....	29
Figure 20: Installation offset.....	31

8 List of tables

Table 1: Assignment of the M12 coupler.....	30
---	----



**EU-Konformitätserklärung
EU Declaration of Conformity
Déclaration UE de Conformité
Dichiarazione di Conformità UE**



FAFNIR GmbH, Deutschland / Germany / Allemagne / Germania

erklärt als Hersteller in alleiniger Verantwortung, dass die Produkte
declares as manufacturer under sole responsibility that the products
déclare sous sa seule responsabilité en qualité de fabricant que les produits
dichiara sotto la sola responsabilità del produttore, che i prodotti sono

**Füllstandsensoren / Filling Level Sensors / Capteurs de Niveau / Sensori di livello
TORRIX ... / VISY-Stick ...**

den Vorschriften der europäischen Richtlinien
comply with the regulations of the European directives
sont conformes aux réglementations des directives européennes suivantes
rispetta i regolamenti delle direttive europee

2011/65/EU	Beschränkung der Verwendung bestimmter gefährlicher Stoffe in Elektro- und Elektronikgeräten	RoHS
2011/65/EU	Restriction of the use of certain hazardous substances in electrical and electronic equipment	RoHS
2011/65/EU	Limitation de l'utilisation de certaines substances dangereuses dans les équipements électriques et électroniques	RoHS
2011/65/EU	Restrizione dell'uso di determinate sostanze pericolose nelle apparecchiature elettriche ed elettroniche	RoHS
2014/30/EU	Elektromagnetische Verträglichkeit	EMV
2014/30/EU	Electromagnetic compatibility	EMC
2014/30/EU	Compatibilité électromagnétique	CEM
2014/30/EU	Compatibilità elettromagnetica	CEM
2014/34/EU	Geräte und Schutzsysteme zur bestimmungsgemäßen Verwendung in explosionsgefährdeten Bereichen	ATEX
2014/34/EU	Equipment and protective systems intended for use in potentially explosive atmospheres	ATEX
2014/34/EU	Appareils et systèmes de protection destinés à être utilisés en atmosphères explosibles	ATEX
2014/34/EU	Apparecchi e sistemi di protezione destinati a essere utilizzati in atmosfera potenzialmente esplosiva	ATEX

durch die Anwendung folgender harmonisierter Normen entsprechen
by applying the harmonised standards
par l'application des normes
applicando le norme armonizzate

**RoHS / RoHS / RoHS / RoHS
EMV / EMC / CEM / CEM
ATEX / ATEX / ATEX / ATEX**

**EN 50581:2012
EN 61326-1:2013
EN IEC 60079-0:2018
EN 60079-11:2012
EN 60079-26:2015**

Die Produkte sind bestimmt als Elektro- und Elektronikgeräte der RoHS-
The products are determined as electrical and electronic equipment of RoHS
Les produits sont déterminés comme des équipements électriques et électroniques de RoHS
I prodotti sono determinati come apparecchiature elettriche ed elettroniche della RoHS

Kategorie / Category / Catégorie / Categoria

**Überwachungs- und Kontrollinstrumenten in der Industrie /
Industrial Monitoring and Control Instruments /
Instruments de contrôle et de surveillance industriels /
Strumenti di monitoraggio e controllo industriali**

Die Produkte entsprechen den EMV-Anforderungen
The products comply with the EMC requirements
Les produits sont conformes aux exigences CEM
I prodotti sono conformi ai requisiti CEM

**Störaussendung / Emission / Émission / L'emissione
Störfestigkeit / Immunity / D'immunité / Immunità**

**Klasse B / Class B / Classe B / Classe B
Industrielle elektromagnetische Umgebung /
Industrial electromagnetic environment /
Environnement électromagnétique industriel /
Ambiente elettromagnetico industriale**

Die notifizierte Stelle TÜV NORD CERT GmbH, 0044 hat eine EU-Baumusterprüfung durchgeführt und folgende Bescheinigung ausgestellt
The notified body TÜV NORD CERT GmbH, 0044 performed a EU-type examination and issued the certificate
L'organisme notifié TÜV NORD CERT GmbH, 0044 a effectué examen UE de type et a établi l'attestation
L'organismo notificato TÜV NORD CERT GmbH, 0044 ha effettuato esame UE del tipo e rilasciato il certificato

TORRIX Ex ... / VISY-Stick ...

TÜV 99 ATEX 1496 X

Hamburg, 30.03.2020

Ort, Datum / Place, Date / Lieu, Date / Luogo, data

Geschäftsführer / Managing Director / Gérant / Direttore Generale: René Albrecht

Translation

(1) **EU-Type Examination Certificate**

(2) Equipment and protective systems intended for use in potentially explosive atmospheres, **Directive 2014/34/EU**



(3) **Certificate Number** TÜV 99 ATEX 1496 X **issue:** 02

(4) for the product: Filling Level Sensor type VISY-Stick ... and type TORRIX Ex ...

(5) of the manufacturer: **FAFNIR GmbH**

(6) Address: Schnackenburgallee 149 c, 22525 Hamburg, Germany

Order number: 8003011045

Date of issue: 2020-02-19

(7) The design of this product and any acceptable variation thereto are specified in the schedule to this EU-Type Examination Certificate and the documents therein referred to.

(8) The TÜV NORD CERT GmbH, Notified Body No. 0044, in accordance with Article 17 of the Directive 2014/34/EU of the European Parliament and the Council of 26 February 2014, certifies that this product has been found to comply with the Essential Health and Safety Requirements relating to the design and construction of products intended for use in potentially explosive atmospheres given in Annex II to the Directive.

The examination and test results are recorded in the confidential ATEX Assessment Report No. 20 203 254816.

(9) Compliance with the Essential Health and Safety Requirements has been assured by compliance with:

EN IEC 60079-0:2018

EN 60079-11:2012

EN 60079-26:2015

except in respect of those requirements listed at item 18 of the schedule.

(10) If the sign "X" is placed after the certificate number, it indicates that the product is subject to the Specific Conditions for Use specified in the schedule to this certificate.

(11) This EU-Type Examination Certificate relates only to the design, and construction of the specified product. Further requirements of the Directive apply to the manufacturing process and supply of this equipment. These are not covered by this certificate.

(12) The marking of the product shall include the following:



See item 15 of the schedule

TÜV NORD CERT GmbH, Langemarckstraße 20, 45141 Essen, notified by the central office of the countries for safety engineering (ZLS), Ident. Nr. 0044, legal successor of the TÜV NORD CERT GmbH & Co. KG Ident. Nr. 0032

The head of the notified body



Roder

Hanover office, Am TÜV 1, 30519 Hannover, Tel. +49 511 998-61455, Fax +49 511 998-61590

(13) **SCHEDULE**

(14) **EU-Type Examination Certificate No. TÜV 99 ATEX 1496 X issue 02**

(15) Description of product

The filling level sensors are used for continuous measurement of liquid levels within potentially explosive areas. Floaters are used to detect the fluid levels. These slide on a sensor tube. For interface or water detection, a second float can be mounted on the sensor tube. In addition, the density of the liquid can be determined by means of a density module. The temperature measuring chain VISY-Stick ... Temp ... is used to measure temperatures at different heights and does not use any floats.

The filling level sensors type VISY-Stick ... and type TORRIX Ex ... may also be manufactured according to the test documents listed in the ATEX test report. The changes affect the internal structure as well as the change of temperature classes. Furthermore, the equipment was assessed according to the latest standards.

The marking is as follows:

Type TORRIX Ex ...

	II 1 G Ex ia IIC T6...T4 Ga	resp.	II 1/2 G Ex ia IIC T6...T4 Ga/Gb	resp.
	II 2 G Ex ia IIC T6...T4 Gb	resp.	II 1 D Ex ia IIIC T160 °C Da	

Type TORRIX Ex ...-A resp. TORRIX Ex ... Flex resp. TORRIX Ex ... PL

	II 1 G Ex ia IIB T6...T4 Ga	resp.	II 1/2 G Ex ia IIB T6...T4 Ga/Gb	resp.
	II 2 G Ex ia IIB T6...T4 Gb	resp.	II 1 D Ex ia IIIC T160 °C Da	

Type VISY-Stick ... resp. VISY-Stick (Flex) Temp resp. TORRIX Ex SC...

	II 1 G Ex ia IIC T6...T5 Ga	resp.	II 1/2 G Ex ia IIC T6...T4 Ga/Gb	resp.
	II 2 G Ex ia IIC T6...T4 Gb	resp.	II 1 D Ex ia IIIC T135 °C Da	

Type VISY-Stick Advanced ... resp. VISY-Stick ... Flex ... resp.

TORRIX Ex SC...-A resp. TORRIX Ex SC... Flex resp. TORRIX Ex SC... PL

	II 1 G Ex ia IIB T6...T5 Ga	resp.	II 1/2 G Ex ia IIB T6...T4 Ga/Gb	resp.
	II 2 G Ex ia IIB T6...T4 Gb	resp.	II 1 D Ex ia IIIC T135 °C Da	

Type VISY-Stick ... RS485 resp. VISY-Stick (Flex) Temp RS485 resp.

TORRIX Ex C... resp. TORRIX Ex RS485... resp. TORRIX Ex TAG...

	II 1 G Ex ia IIC T6...T4 Ga	resp.	II 1/2 G Ex ia IIC T6...T4 Ga/Gb	resp.
	II 2 G Ex ia IIC T6...T4 Gb	resp.	II 1 D Ex ia IIIC T125 °C Da	

Type VISY-Stick ... Advanced RS485 resp. VISY-Stick ... Flex RS485 resp.

TORRIX Ex C...-A resp. TORRIX Ex RS485...-A resp. TORRIX Ex TAG...-A resp.

TORRIX Ex C... Flex resp. TORRIX Ex RS485... Flex resp. TORRIX Ex TAG... Flex resp.

TORRIX Ex C... PL resp. TORRIX Ex RS485... PL resp. TORRIX Ex TAG... PL

	II 1 G Ex ia IIB T6...T4 Ga	resp.	II 1/2 G Ex ia IIB T6...T4 Ga/Gb	resp.
	II 2 G Ex ia IIB T6...T4 Gb	resp.	II 1 D Ex ia IIIC T125 °C Da	

Schedule to EU-Type Examination Certificate No. TÜV 99 ATEX 1496 X issue 02

Type VISY-Stick ... TLS resp. VISY-Stick (Flex) Temp TLS

	II 1 G Ex ia IIC T4 Ga	resp.	II 1/2 G Ex ia IIC T4...T3 Ga/Gb	resp.
	II 2 G Ex ia IIC T4...T3 Gb	resp.	II 1 D Ex ia IIIC T195 °C Da	

Type VISY-Stick ... Advanced TLS resp. VISY-Stick ... Flex TLS

	II 1 G Ex ia IIB T4 Ga	resp.	II 1/2 G Ex ia IIB T4...T3 Ga/Gb	resp.
	II 2 G Ex ia IIB T4...T3 Gb	resp.	II 1 D Ex ia IIIC T195 °C Da	

Type designation:

Type VISY-Stick ... (only Ex relevant nomenclatures):

VISY-Stick Sump ...	Environmental sensor (Leakage control)
VISY-Stick Advanced ...	Advanced precision of measurement and temperature sensors
VISY-Stick Flex ...	Flexible sensor tube
VISY-Stick ...	Serial communication
VISY-Stick ... RS485	RS-485 interface
VISY-Stick ... Temp ...	Temperature measuring chain
VISY-Stick ... TLS	TLS interface

Type TORRIX Ex ... (only Ex relevant nomenclatures):

TORRIX Ex ...	4...20 mA interface (with configuration buttons) optionally with HART protocol
TORRIX Ex C...	4...20 mA interface (without configuration buttons) optionally with HART protocol
TORRIX Ex RS485...	RS-485 interface
TORRIX Ex SC...	Serial communication
TORRIX Ex TAG...	TAG interface (communication in accordance with EN 14116)
TORRIX Ex ...-A	Advanced precision of measurement and temperature sensors
TORRIX Ex ... Flex	Flexible sensor tube
TORRIX Ex ... PL	With plastic coating against very aggressive media

Technical data:

Type VISY-Stick ... resp. TORRIX Ex SC...

Signal- and power circuit
(terminals +, -, A, B)

in type of protection "Intrinsic Safety" Ex ia IIC/IIB/IIIC
only for the connection to a certified intrinsically safe circuit

Maximum values: $U_i = 15 \text{ V}$
 $I_i = 60 \text{ mA}$
 $P_i = 100 \text{ mW}$
 $L_i = 100 \text{ } \mu\text{H}$
 $C_i = 10 \text{ nF}$

The types VISY-Stick Advanced, VISY-Stick Flex, TORRIX Ex SC...-A, TORRIX Ex SC... Flex and TORRIX Ex SC... PL are only for gas group IIB allowed.

Schedule to EU-Type Examination Certificate No. TÜV 99 ATEX 1496 X issue 02

Type VISY-Stick ... RS485 resp. TORRIX Ex ...

Signal- and power circuit

(terminals +, -, A, B resp. +, -) in type of protection "Intrinsic Safety" Ex ia IIC/IIB/IIIC only for the connection to a certified intrinsically safe circuit

Maximum values: $U_i = 30 \text{ V}$
 $I_i = 200 \text{ mA}$ at $T_a \leq +70 \text{ °C}$ resp.
 $I_i = 100 \text{ mA}$ at $T_a \leq +85 \text{ °C}$
 $P_i = 1 \text{ W}$
 $L_i = 20 \text{ }\mu\text{H}$
 $C_i = 10 \text{ nF}$

The types VISY-Stick Advanced RS485, VISY-Stick Flex RS485, TORRIX Ex ...-A, TORRIX Ex ... Flex and TORRIX Ex ... PL are only for gas group IIB allowed.

Type VISY-Stick ... TLS

Signal- and power circuit

(terminals +, -)

in type of protection "Intrinsic Safety" Ex ia IIC/IIB/IIIC only for the connection to a certified intrinsically safe circuit

Maximum values: $U_i = 13 \text{ V}$
 $I_i = 200 \text{ mA}$
 $P_i = 625 \text{ mW}$
 $L_i = 410 \text{ }\mu\text{H}$
 $C_i = 20 \text{ nF}$

The types VISY-Stick Advanced TLS and VISY-Stick Flex TLS are only for gas group IIB allowed.

Permissible ambient temperature range:

Use as category 1G apparatus

Type VISY-Stick ... resp. TORRIX Ex SC...

Temperature class	Ambient and Medium temperature range
T6	-20 °C to +50 °C
T1 to T5	-20 °C to +60 °C

Type VISY-Stick ... RS485 resp. TORRIX Ex ...

Temperature class	Ambient and Medium temperature range
T6	$I_i \leq 100 \text{ mA}$: -20 °C to +40 °C $I_i \leq 200 \text{ mA}$: -20 °C to +25 °C
T5	$I_i \leq 100 \text{ mA}$: -20 °C to +55 °C $I_i \leq 200 \text{ mA}$: -20 °C to +40 °C
T1 to T4	-20 °C to +60 °C

The process pressure for the media must be between 0.8 bar and 1.1 bar where explosive vapour-air mixtures are present. If no explosive mixtures are present, the equipment may also be operated outside this area according to the manufacturer's specification.

Schedule to EU-Type Examination Certificate No. TÜV 99 ATEX 1496 X issue 02

Use as category 1/2G apparatus

Type VISY-Stick ... resp. TORRIX Ex SC...

Temperature class	Ambient temperature range	Medium temperature range
T6	-40 °C to +50 °C	-20 °C to +50 °C
T5	-40 °C to +65 °C	-20 °C to +60 °C
T1 to T4	-40 °C to +85 °C	-20 °C to +60 °C

Type VISY-Stick ... RS485 resp. TORRIX Ex ...

Temperature class	Ambient temperature range	Medium temperature range
T6	$I_i \leq 100 \text{ mA}$: -40 °C to +40 °C	$I_i \leq 100 \text{ mA}$: -20 °C to +40 °C
	$I_i \leq 200 \text{ mA}$: -40 °C to +25 °C	$I_i \leq 200 \text{ mA}$: -20 °C to +25 °C
T5	$I_i \leq 100 \text{ mA}$: -40 °C to +55 °C	$I_i \leq 100 \text{ mA}$: -20 °C to +55 °C
	$I_i \leq 200 \text{ mA}$: -40 °C to +40 °C	$I_i \leq 200 \text{ mA}$: -20 °C to +40 °C
T1 to T4	$I_i \leq 100 \text{ mA}$: -40 °C to +85 °C $I_i \leq 200 \text{ mA}$: -40 °C to +70 °C	-20 °C to +60 °C

Type VISY-Stick ... TLS

Temperature class	Ambient temperature range	Medium temperature range
T4	-40 °C to +75 °C	-20 °C to +60 °C
T1 to T3	-40 °C to +85 °C	-20 °C to +60 °C

The process pressure for the media must be between 0.8 bar and 1.1 bar where explosive vapour-air mixtures are present. If no explosive mixtures are present, the equipment may also be operated outside this area according to the manufacturer's specification.

Use as category 2G apparatus

Type VISY-Stick ... resp. TORRIX Ex SC...

Temperature class	Ambient temperature range	Medium temperature range
T6	-40 °C to +50 °C	-40 °C to +85 °C
T5	-40 °C to +65 °C	-40 °C to +100 °C
T4	-40 °C to +85 °C	-40 °C to +135 °C
T3	-40 °C to +85 °C	-40 °C to +200 °C
T2	-40 °C to +85 °C	-40 °C to +300 °C
T1	-40 °C to +85 °C	-40 °C to +450 °C

Type VISY-Stick ... RS485 resp. TORRIX Ex ...

Temperature class	Ambient temperature range	Medium temperature range
T6	$I_i \leq 100 \text{ mA}$: -40 °C to +40 °C	-40 °C to +85 °C
	$I_i \leq 200 \text{ mA}$: -40 °C to +25 °C	
T5	$I_i \leq 100 \text{ mA}$: -40 °C to +55 °C	-40 °C to +100 °C
	$I_i \leq 200 \text{ mA}$: -40 °C to +40 °C	
T4	$I_i \leq 100 \text{ mA}$: -40 °C to +85 °C	-40 °C to +135 °C
	$I_i \leq 200 \text{ mA}$: -40 °C to +70 °C	
T3	$I_i \leq 100 \text{ mA}$: -40 °C to +85 °C	-40 °C to +200 °C
	$I_i \leq 200 \text{ mA}$: -40 °C to +70 °C	
T2	$I_i \leq 100 \text{ mA}$: -40 °C to +85 °C	-40 °C to +300 °C
	$I_i \leq 200 \text{ mA}$: -40 °C to +70 °C	
T1	$I_i \leq 100 \text{ mA}$: -40 °C to +85 °C	-40 °C to +450 °C
	$I_i \leq 200 \text{ mA}$: -40 °C to +70 °C	

Schedule to EU-Type Examination Certificate No. TÜV 99 ATEX 1496 X issue 02

Type VISY-Stick ... TLS

Temperature class	Ambient temperature range	Medium temperature range
T4	-40 °C to +75 °C	-40 °C to +135 °C
T3	-40 °C to +85 °C	-40 °C to +200 °C
T2	-40 °C to +85 °C	-40 °C to +300 °C
T1	-40 °C to +85 °C	-40 °C to +450 °C

Use as category 1D apparatus

Type TORRIX Ex ...

Maximum surface temperature		Ambient temperature T_a
Dust layer ≤ 5 mm	Immersed in dust	
$T_a + 75$ °C	Observe EN 60079-14	-40 °C to +85 °C

Type VISY-Stick ... resp. TORRIX Ex SC...

Maximum surface temperature		Ambient temperature T_a
Dust layer ≤ 5 mm	Immersed in dust	
$T_a + 30$ °C	135 °C	-40 °C to +85 °C

Type VISY-Stick ... TLS

Maximum surface temperature		Ambient temperature T_a
Dust layer ≤ 5 mm	Immersed in dust	
135 °C	135 °C	-40 °C to +77 °C
$T_a + 110$ °C	Observe EN 60079-14	-40 °C to +85 °C

Type VISY-Stick ... RS485 resp. TORRIX Ex C... resp. TORRIX Ex RS485... resp. TORRIX Ex TAG...

Maximum surface temperature		Ambient temperature T_a
Dust layer ≤ 5 mm	Immersed in dust	
$I_i \leq 100$ mA: $T_a + 40$ °C	Observe EN 60079-14	-40 °C to +85 °C
$I_i \leq 200$ mA: $T_a + 55$ °C	Observe EN 60079-14	-40 °C to +70 °C

All further data are valid unchanged.

(16) Drawings and documents are listed in the ATEX Assessment Report No. 20 203 254816

(17) Specific Conditions for Use

1. When using Titanium Floats or Sump Environmental Sensors, the risk of ignition due to impact or friction shall be avoided.
2. When using plastic floats, there is a danger of ignition due to electrostatic discharge. The manufacturer's instructions must be observed.

(18) Essential Health and Safety Requirements

no additional ones

- End of Certificate -



Instructions in accordance with directive 2014/34/EU

TÜV 99 ATEX 1496 X

Filling Level Sensors type VISY Stick ... and type TORRIX Ex ...

Version: 02.2020

I Range of application

The filling level sensors are designed for continuous measurement of liquid levels. Floats are used to measure the liquid levels. These slide on a sensor tube. For interface or water detection, a second float can be mounted on the sensor tube. In addition, the density of the liquid can be determined via a density module. The temperature measuring chain VISY-Stick ... Temp ... is used to measure temperatures at different heights and does not use any floats.

The power supply for the devices VISY-Stick ... and the forwarding of the measured data to a superordinate evaluation system is provided by isolating amplifier VP-... or VPI or, in the case of the sensor VISY-Stick ... TLS, e.g. by the TLS-... console from Veeder-Root. If an RS-485 interface is used, the sensor VISY-Stick ... RS485 can be used.

The filling level sensors TORRIX Ex ... can be produced with different interfaces. These are, for example, interfaces "4 ... 20 mA" (TORRIX Ex ... and TORRIX Ex C...), "RS-485" (TORRIX Ex RS485...) or TAG (TORRIX Ex TAG...). The filling level sensors TORRIX Ex SC... are connected to the isolating amplifier VP-... or VPI.

II Standards

The device is designed according to the following European standards

EN IEC 60079-0:2018	Equipment – General requirements
EN 60079-11:2012	Equipment protection by intrinsic safety "i"
EN 60079-26:2015	Equipment with Equipment Protection Level (EPL) Ga

III Instructions for safe ...

III.a ... use

The approval applies to equipment types VISY-Stick ... and TORRIX Ex ...

The devices are designed as intrinsically safe apparatuses and are approved for use in potentially explosive areas. The "advanced" (TORRIX Ex ...-A, VISY-Stick Advanced ...) and "flexible" filling level sensors (TORRIX Ex ... Flex, VISY-Stick ... Flex ...) as well as types with plastic coating against very aggressive media (TORRIX Ex ... PL) can be used for all gases of groups IIA and IIB. The temperature measuring chain VISY-Stick ... Temp ... and all other filling level sensors can be used for all gases of groups IIA, IIB and IIC. In addition, all devices can be used for dust groups IIIA, IIIB and IIIC.

To use a non-conductive plastic floats in potentially explosive areas with gases of group IIC the hazard of static charging must be prevented. Here a few conditions need to be observed:

- The use of the float in strongly flowing, non-conductive liquids is forbidden;
- There must be no agitator/mixer in the tank;
- Frictions on non-conductive components are to be avoided;
- The float must not be cleaned in a dry state.

III.b ... assembling and dismantling

The assembly and disassembly must solely be carried out with the power disconnected!

Prior to the installation, it may be necessary that the float/s or the density module is disassembled. During the assembly it must be ensured that the float/s or the module is/are mounted the right way on the sensor tube.

Only with the TORRIX Ex ... with screw terminals the opening of the sensor head is planned. Further disassembly may damage the filling level sensor and void its approval.



III.c ... installation

All wiring operations must solely be carried out with the power disconnected. Special rules and regulations, including EN 60079-14 and local installation regulations, must be observed.

If a device is supplied with screw-in unit, the thread of the screw-in unit must be fitted with a suitable sealing material, screwed into the existing sleeve and tightened. In case of a riser installation the plastic centring aid is plugged onto the sensor head. Then allow the sensor to slide into the riser tube until it stands firmly on the bottom. If the filling level sensor is supplied without process fitting, the installer is responsible for compliance with the Ex requirements.

General information (see also EN 60079-26, Clause 4.3):

If a device is installed into the boundary wall between zone 0 and zone 1, it is essential to ensure that a minimum protection of IP66 or IP67 is achieved after installation.

Through the process connection, there may be an opening in the boundary wall to the area requiring EPL Ga. There is then the risk of the release of flammable gas and the flame entrance.

Flexible filling level sensor (TORRIX Ex ... Flex ..., VISY-Stick ... Flex ...)

This type can be produced with different sensor bases to serve for stabilizing the sensor. A base can be a magnetic base. The magnet is then encapsulated in an electricity conducting plastic and can therefore be used in potentially explosive areas.

If this version is manufactured without a fixture, it may only be used in non-flowing liquids or it must be ensured that it does not turn, e.g. by a protective tube or by a weight as a sensor foot.

LPG filling level sensor VISY-Stick ... LPG ...

The adjustable installation kit for LPG tanks was developed to allow the sensor to be installed and removed at any time without any additional work and without having to open the tank. The adjustable installation kit for LPG tanks consists of a jacket pipe with special LPG float made of BUNA and a 3/4" NPT cutting ring fitting. In the case of installation with a cutting ring fitting, the position of the sensor can no longer be altered after the union nut has been tightened.

Environmental sensor VISY-Stick Sump ...

This environmental sensor can be fixed with the mounting kit.

When wiring the sensor to the associated apparatus (preferably blue coloured cable), the approved inductance and capacitance of the associated apparatus must not be exceeded. The terminals of the sensor must be connected to the same terminals of the isolating amplifier.

For the filling level sensors with screw terminals type TORRIX Ex ... and TORRIX Ex HART ... the terminal designation is "+" and "-" For devices with M12 plug, the pin assignments are as follows:

Pin	TORRIX Ex SC ... VISY-Stick ...	TORRIX Ex C ... TORRIX Ex TAG ... VISY-Stick ... TLS	TORRIX Ex RS485 ... VISY-Stick ... RS485	M12 cable (female)
1	+	+	+	
2	A		A (+)	
3	-	-	-	
4	B		B (-)	

Table 1: Pin assignment of the sensors

The sensors must be integrated into the potential equalization of the hazardous area. A PA connecting terminal on the sensor head is available for integration of the devices into the potential equalization.



General information (see also EN 60079-14:2013, clause 6.4.1):

Exposed conductive parts need not be separately connected to the equipotential bonding system if they are firmly secured to and are in conductive contact with structural parts or piping which are connected to the equipotential bonding system.

III.d ... adjustment

For the operation the sensors, no Ex-relevant adjustments are necessary.

III.e ... putting into service

Before putting into service, all devices must be checked for correct connection and installation. The electrical supply, including the connected devices, must be checked.

III.f ... maintenance (servicing and emergency repair)

The apparatus is generally maintenance-free. In the case of a defect, this must be returned to the manufacturer FAFNIR or one of its representatives.

In accordance with the requirements for dielectric strength according to EN 60079-11, Clause 6.3.13 there is compliance with the insulation test between the intrinsically safe circuit and the chassis of the device with a voltage of 500 V_{AC}.

Warning: The type VISY-Stick Sump ... and floats made of non-conductive plastic must only be cleaned with a damp cloth, to minimize the risk of electrostatic charging.

IV Equipment marking

- 1 Manufacturer: FAFNIR GmbH, 22525 Hamburg
- 2 Type designation: TORRIX Ex ... / VISY-Stick ...
- 3 Certificate number: TÜV 99 ATEX 1496 X
- 4 Ex marking:
- 4a according to directive:
 II 1 GD
II 1/2 G
II 2 G
- 4b according to standards:
TORRIX Ex ...

Ex ia IIC T6...T4 Ga
Ex ia IIC T6...T4 Ga/Gb
Ex ia IIC T6...T4 Gb
Ex ia IIIC T160 °C Da

TORRIX Ex ...-A / TORRIX Ex ... Flex / TORRIX Ex ... PL

Ex ia IIB T6...T4 Ga
Ex ia IIB T6...T4 Ga/Gb
Ex ia IIB T6...T4 Gb
Ex ia IIIC T160 °C Da

TORRIX Ex SC... / VISY-Stick ... / VISY-Stick (Flex) Temp

Ex ia IIC T6...T5 Ga
Ex ia IIC T6...T4 Ga/Gb
Ex ia IIC T6...T4 Gb
Ex ia IIIC T135 °C Da



*TORRIX Ex SC...-A / TORRIX Ex SC... Flex / TORRIX Ex SC... PL /
VISY-Stick Advanced ... / VISY-Stick ... Flex ...*

Ex ia IIB T6...T5 Ga
Ex ia IIB T6...T4 Ga/Gb
Ex ia IIB T6...T4 Gb
Ex ia IIIC T135 °C Da

*TORRIX Ex C... / TORRIX Ex RS485... / TORRIX Ex TAG... /
VISY-Stick ... RS485 / VISY-Stick (Flex) Temp RS485*

Ex ia IIC T6...T4 Ga
Ex ia IIC T6...T4 Ga/Gb
Ex ia IIC T6...T4 Gb
Ex ia IIIC T125°C Da

*TORRIX Ex C...-A / TORRIX Ex C... Flex / TORRIX Ex C... PL /
TORRIX Ex RS485...-A / TORRIX Ex RS485... Flex / TORRIX Ex RS485... PL /
TORRIX Ex TAG...-A / TORRIX Ex TAG... Flex / TORRIX Ex TAG... PL /
VISY-Stick Advanced ... RS485 / VISY-Stick ... Flex ... RS485*

Ex ia IIB T6...T4 Ga
Ex ia IIB T6...T4 Ga/Gb
Ex ia IIB T6...T4 Gb
Ex ia IIIC T125°C Da

VISY-Stick ... TLS / VISY-Stick (Flex) Temp TLS

Ex ia IIC T4 Ga
Ex ia IIC T4...T3 Ga/Gb
Ex ia IIC T4...T3 Gb
Ex ia IIIC T195°C Da

VISY-Stick Advanced ... TLS / VISY-Stick ... Flex ... TLS

Ex ia IIB T4 Ga
Ex ia IIB T4...T3 Ga/Gb
Ex ia IIB T4...T3 Gb
Ex ia IIIC T195°C Da

- | | | |
|---|-------------------|--|
| 5 | *Warning marking: | WARNING – Potential electrostatic charging hazard – See instructions |
| 6 | CE marking: |  0044 |
| 7 | Technical data: | See instructions for technical data |



V Technical data

The following electrical input values apply to the filling level sensors:

Electrical variable	TORRIX Ex SC... VISY-Stick ...	VISY-Stick ... TLS	TORRIX Ex ... TORRIX Ex C... TORRIX Ex RS485... TORRIX Ex TAG... VISY-Stick ... RS485
$U_i \leq$	15 V	13 V	30 V
$I_i \leq$	60 mA	200 mA	100 mA / 200 mA*
$P_i \leq$	100 mW	625 mW	1 W
$C_i <$	10 nF	20 nF	10 nF
$L_i <$	100 μ H	410 μ H	20 μ H

Table 2: Electrical input data of filling level sensors

When using the equipment in potentially explosive gas atmospheres please consult table 3 to table 5 for the maximum temperatures depending on temperature classes and category respectively equipment protection levels.

Type TORRIX Ex SC... / VISY-Stick ...

Temperature class	T_a	T_F
Category 1G resp. EPL Ga (filling level sensor completely installed in zone 0)		
T6	-20 °C ... +50 °C	
T5, T4, T3, T2, T1	-20 °C ... +60 °C	
Category 1/2G resp. EPL Ga/Gb (sensor head installed in zone 1, Sensor pipe in zone 0)		
T6	-40 °C ... +50 °C	-20 °C ... +50 °C
T5	-40 °C ... +65 °C	-20 °C ... +60 °C
T4, T3, T2, T1	-40 °C ... +85 °C	
Category 2G resp. EPL Gb (filling level sensor completely installed in Zone 1)		
T6	-40 °C ... +50 °C	-40 °C ... +85 °C
T5	-40 °C ... +65 °C	-40 °C ... +100 °C
T4	-40 °C ... +85 °C	-40 °C ... +135 °C
T3		-40 °C ... +200 °C
T2		-40 °C ... +300 °C
T1		-40 °C ... +450 °C

Table 3: Service temperatures of the filling level sensors in basic version (without interface board)

* The permissible input current I_i depends on the ambient temperature T_a



Type TORRIX Ex ... / TORRIX Ex C... / TORRIX Ex RS485... / TORRIX Ex TAG... / VISY-Stick ... RS485

Temperature class	T _a	T _F
Category 1G resp. EPL Ga (filling level sensor completely installed in zone 0)		
T6	$I_i \leq 100 \text{ mA: } -20 \text{ °C ... } +40 \text{ °C}$ $I_i \leq 200 \text{ mA: } -20 \text{ °C ... } +25 \text{ °C}$	
T5	$I_i \leq 100 \text{ mA: } -20 \text{ °C ... } +55 \text{ °C}$ $I_i \leq 200 \text{ mA: } -20 \text{ °C ... } +40 \text{ °C}$	
T4, T3, T2, T1	-20 °C ... +60 °C	
Category 1/2G resp. EPL Ga/Gb (sensor head installed in zone 1, Sensor pipe in zone 0)		
T6	$I_i \leq 100 \text{ mA: } -40 \text{ °C ... } +40 \text{ °C}$ $I_i \leq 200 \text{ mA: } -40 \text{ °C ... } +25 \text{ °C}$	$I_i \leq 100 \text{ mA: } -20 \text{ °C ... } +40 \text{ °C}$ $I_i \leq 200 \text{ mA: } -20 \text{ °C ... } +25 \text{ °C}$
T5	$I_i \leq 100 \text{ mA: } -40 \text{ °C ... } +55 \text{ °C}$ $I_i \leq 200 \text{ mA: } -40 \text{ °C ... } +40 \text{ °C}$	$I_i \leq 100 \text{ mA: } -20 \text{ °C ... } +55 \text{ °C}$ $I_i \leq 200 \text{ mA: } -20 \text{ °C ... } +40 \text{ °C}$
T4, T3, T2, T1	$I_i \leq 100 \text{ mA: } -40 \text{ °C ... } +85 \text{ °C}$ $I_i \leq 200 \text{ mA: } -40 \text{ °C ... } +70 \text{ °C}$	-20 °C ... +60 °C
Category 2G resp. EPL Gb (filling level sensor completely installed in Zone 1)		
T6	$I_i \leq 100 \text{ mA: } -40 \text{ °C ... } +40 \text{ °C}$ $I_i \leq 200 \text{ mA: } -40 \text{ °C ... } +25 \text{ °C}$	-40 °C ... +85 °C
T5	$I_i \leq 100 \text{ mA: } -40 \text{ °C ... } +55 \text{ °C}$ $I_i \leq 200 \text{ mA: } -40 \text{ °C ... } +40 \text{ °C}$	-40 °C ... +100 °C
T4	$I_i \leq 100 \text{ mA: } -40 \text{ °C ... } +85 \text{ °C}$ $I_i \leq 200 \text{ mA: } -40 \text{ °C ... } +70 \text{ °C}$	-40 °C ... +135 °C
T3		-40 °C ... +200 °C
T2		-40 °C ... +300 °C
T1		-40 °C ... +450 °C

Table 4: Service temperatures of the filling level sensors with 4 ... 20 mA, RS-485 or TAG interface
Type VISY-Stick ... TLS

Temperature class	T _a	T _F
Category 1G resp. EPL Ga (filling level sensor completely installed in zone 0)		
T4, T3, T2, T1	-20 °C ... +60 °C	
Category 1/2G resp. EPL Ga/Gb (sensor head installed in zone 1, Sensor pipe in zone 0)		
T4	-40 °C ... +75 °C	-20 °C ... +60 °C
T3, T2, T1	-40 °C ... +85 °C	
Category 2G resp. EPL Gb (filling level sensor completely installed in Zone 1)		
T4	-40 °C ... +75 °C	-40 °C ... +135 °C
T3	-40 °C ... +85 °C	-40 °C ... +200 °C
T2		-40 °C ... +300 °C
T1		-40 °C ... +450 °C

Table 5: Service temperatures of the filling level sensors with TLS interface

For use in category 1G resp. 1/2G, the following applies:

The process pressure for the media must be between 0.8 bar and 1.1 bar where explosive vapour-air mixtures are present. If no explosive mixtures are present, the equipment may also be operated outside this area according to the manufacturer's specification.



It must be ensured through appropriate measures that the temperature (T_a) for the respective temperature class is not exceeded at any point on the sensor head.

General information (see also EN IEC 60079-0, Clause 1):

Zone 0 exists only under atmospheric conditions:

Temperature range: -20 °C ... +60 °C
 Pressure range: 0.8 bar ... 1.1 bar
 Oxidants: Air (oxygen content about 21 %)

When using the equipment in potentially explosive dust atmospheres please consult table 6 for the maximum ambient temperatures depending on the maximum surface temperature and dust layer.

Category 1D resp. equipment protection level Da (filling level sensor installed in zone 20)

Maximum surface temperature		Ambient temperature T_a
dust layer ≤ 5 mm	immersed in dust	
Types TORRIX Ex SC... / VISY-Stick ...		
$T_a + 30$ °C	135 °C	-40 °C ... +85 °C
Types VISY-Stick ... TLS		
135 °C		-40 °C ... +77 °C
$T_a + 110$ °C	Observe EN 60079-14*	-40 °C ... +85 °C
Types TORRIX Ex C... / TORRIX Ex RS485... / TORRIX Ex TAG... / VISY-Stick ... RS485		
$I_i \leq 100$ mA: $T_a + 40$ °C	Observe EN 60079-14*	-40 °C ... +85 °C
$I_i \leq 200$ mA: $T_a + 55$ °C		-40 °C ... +70 °C
Types TORRIX Ex ...		
$T_a + 75$ °C	Observe EN 60079-14*	-40 °C ... +85 °C

Table 6: Service temperatures for potentially explosive dust atmospheres

The filling level sensors achieve a degree of protection:

Protection rating IP68

VI Special conditions of use

1. When using Titanium Floats or Sump Environmental Sensors, the risk of ignition due to impact or friction shall be avoided.
2. When using plastic floats, there is a danger of ignition due to electrostatic discharge.

* For the assessment of the temperature clause 5.6.3.3 of EN 60079-14:2013 can consult
 Page 7/7



Government of India
Ministry of Commerce & Industry
Petroleum & Explosives Safety Organisation (PESO)
5th Floor, A-Block, CGO Complex, Seminary Hills,
Nagpur - 440006

E-mail : explosives@explosives.gov.in
 Phone/Fax No : 0712 -2510248, Fax-2510577

Approval No : A/P/HQ/MH/104/6555 (P479308)

Dated : 22/09/2020

To,

M/s. FAFNIR GmbH,
Scnackenburgallee 149 c,Hamburg
22525
GERMANY

Sub : Approval of Filling Level Sensors. under Petroleum Rules 2002- Regarding.

Sir(s),

Please refer to your letter No. **OIN576302** dated **11/09/2020** on the subject.

The following Ex electrical equipment(s) manufactured by you according to **EN 60079-11 : 2012, EN 60079-26 : 2015, EN/IEC 60079-0: 2018,** standards and covered under **TUV NORD CERT GmbH** Test reports mentioned below is/are approved for use in **Zone 0** of Gas **IIB/IIC** hazardous areas coming under the the Petroleum Rules, 2002 administered by this Organization.

Sr. No	Description	Safety Protection	Equipment reference Number	Test Agency			Drawing no
				Name	Certificate No.	Certificate Date	
1	Filling Level Sensor type VISY-Stick.. and type TORRIX Ex...	Ex ia IIC T6..T4 Ga or Ex ia IIB T6..T4 Ga or Ex ia IIC T6..T5 Ga or Ex ia IIB T6..T5 Ga or Ex ia IIC T4 Ga or Ex ia IIB T4 Ga	P479308/1	TUV NORD CERT GmbH	TUV 99 ATEX 1496 X Issue 02	19/02/2020	PF025B031 Rev B, PF025B059 Rev C

This Approval is granted subject to observance of the following conditions:-

- 1)The design and construction of the equipment shall be strictly in accordance with description, condition and drawings as mentioned in the TUV NORD CERT GmbH Test Reports referred to above.
- 2)The equipment shall be used only with approved type of accessories and associated apparatus.
- 3)Each equipment shall be marked either by raised lettering cast integrally or by plate attached permanently to the main structure to indicate conspicuously:-
 - (a) Name of the manufacturer
 - (b) Name and number by which the equipment is identified.
 - (c) Number & date of the test report of the TUV NORD CERT GmbH applicable to the equipment.
 - (d) Equipment reference number of this letter by which use of apparatus is approved.

(e) Protection level.

4) A certificate to the effect that the equipment has been manufactured strictly in accordance with the drawing referred to in the TUV NORD CERT GmbH Test report and is identical with the one tested and certified at TUV NORD CERT GmbH shall be furnished with each equipment.

5) The customer shall be supplied with a copy of this letter, an extract of the conditions and maintenance schedule, if any, recommended by TUV NORD CERT GmbH in their test reports and copy of instructions booklet detailing operation & maintenance of the equipment so as to maintain its Flame Proof characteristics.

6) The After sales service and maintenance of subject equipment shall be looked after by your representative Gilbarco Veeder Root India Pvt Ltd, B-Wing First Floor Art Guild House, Phoenix Market City, Kurla (West), Mumbai 400 070

This approval also covers the permissible variations as approved under the TUV NORD CERT GmbH test reports referred above. This approval is liable to be cancelled if any of the conditions of the approval is violated or not complied with . The approval may also be amended or withdrawn at any time, if considered necessary in the interest of safety.

The field performance report from actual users/your customers of the subject equipment may please be collected and furnished to this office for verification and record on annual basis.

The Approval is Valid upto **31/12/2024**

Yours faithfully,

(Ninad Dattaram Gawade)
Dy. Controller of Explosives
For Chief Controller of Explosives
Nagpur

Copy to :

1. Jt. Chief Controller of Explosives, West Circle, MUMBAI
2. Gilbarco Veeder Root India Pvt Ltd, B-Wing First Floor Art Guild House, Phoenix Market City, Kurla (West), Mumbai 400 070

for Chief Controller of Explosives
Nagpur

(For more information regarding status, fees and other details please visit our website <http://peso.gov.in>)

This is System Generated document. Signature is not required.

Disclaimer : This page gives the latest action taken by this organization on your application. This page is made available for the information of concerned applicant/licensee only. All efforts have been made to secure this information. However, PESO will not be responsible for any misuse of the information by unauthorized persons including the hackers.



**EU-Konformitätserklärung
EU Declaration of Conformity
Déclaration UE de Conformité**

**FAFNIR GmbH
Schnackenburgallee 149 c
22525 Hamburg
Deutschland / Germany / Allemagne**

erklärt als Hersteller in alleiniger Verantwortung, dass das Produkt
declares as manufacturer under sole responsibility that the product
déclare sous sa seule responsabilité en qualité de fabricant que le produit

**Umweltsensor für Leckage-Erkennung
Environmental Sensor for Leakage Detection
Capteur d'environnement de détection de fuites**

VISY-Reed ...

den Vorschriften der europäischen Richtlinien
complies with the regulations of the European directives
est conforme aux réglementations des directives européennes suivantes

2011/65/EU	Beschränkung der Verwendung bestimmter gefährlicher Stoffe in Elektro- und Elektronikgeräten	RoHS
2011/65/EU	Restriction of the use of certain hazardous substances in electrical and electronic equipment	RoHS
2011/65/UE	Limitation de l'utilisation de certaines substances dangereuses dans les équipements électriques et électroniques	RoHS
2014/30/EU	Elektromagnetische Verträglichkeit	EMV
2014/30/EU	Electromagnetic compatibility	EMC
2014/30/UE	Compatibilité électromagnétique	CEM
2014/34/EU	Geräte und Schutzsysteme zur bestimmungsgemäßen Verwendung in explosionsgefährdeten Bereichen	ATEX
2014/34/EU	Equipment and protective systems intended for use in potentially explosive atmospheres	ATEX
2014/34/UE	Appareils et systèmes de protection destinés à être utilisés en atmosphères explosibles	ATEX

durch die Anwendung folgender harmonisierter Normen entspricht
by applying the harmonised standards
par l'application des normes

**RoHS / RoHS / RoHS
EMV / EMC / CEM
ATEX / ATEX / ATEX**

**EN 50581:2012
EN 61326-1:2013
EN 60079-0:2012 + A11:2013
EN 60079-11:2012
EN 60079-26:2015**

Das Produkt ist bestimmt als Elektro- und Elektronikgerät der RoHS-
The product is determined as electrical and electronic equipment of RoHS
Le produit est déterminé comme des équipements électriques et électroniques de RoHS

Kategorie / Category / Catégorie

**Überwachungs- und Kontrollinstrumenten in der Industrie /
Industrial Monitoring and Control Instruments /
Instruments de contrôle et de surveillance industriels**

Das Produkt entspricht den EMV-Anforderungen
The product complies with the EMC requirements
Le produit est conforme aux exigences CEM

**Störaussendung / Emission / Émission
Störfestigkeit / Immunity / D'immunité**

**Klasse B / Class B / Classe B
Industrielle elektromagnetische Umgebung /
Industrial electromagnetic environment /
Environnement électromagnétique industriel**

Die notifizierte Stelle TÜV NORD CERT GmbH, 0044 hat eine EG-Baumusterprüfung durchgeführt und folgende Bescheinigung ausgestellt
The notified body TÜV NORD CERT GmbH, 0044 performed a EC-type examination and issued the certificate
L'organisme notifié TÜV NORD CERT GmbH, 0044 a effectué examen CE de type et a établi l'attestation

VISY-Reed ...

TÜV 09 ATEX 374581

Hamburg, 31.01.2019
Ort, Datum / Place, Date / Lieu, Date

Geschäftsführer / Managing Director / Gérant: René Albrecht

Translation

(1) **EC-Type Examination Certificate**

TÜV NORD



(2) Equipment and protective systems intended for use in potentially explosive atmospheres, **Directive 94/9/EC**

(3) **Certificate Number** **TÜV 09 ATEX 374581**

(4) for the equipment: Measuring Transmitter VISY-Reed ...

(5) of the manufacturer: FAFNIR GmbH

(6) Address: Bahrenfelder Str. 19
22765 Hamburg
Germany

Order number: 8000374581

Date of issue: 2009-09-10

(7) This equipment or protective system and any acceptable variation thereto are specified in the schedule to this certificate and the documents therein referred to.

(8) The TÜV NORD CERT GmbH, notified body No. 0044 in accordance with Article 9 of the Council Directive of the EC of March 23, 1994 (94/9/EC), certifies that this equipment or protective system has been found to comply with the Essential Health and Safety Requirements relating to the design and construction of equipment and protective systems intended for use in potentially explosive atmospheres given in Annex II to the Directive. The examination and test results are recorded in the confidential report No. 09203374581.

(9) Compliance with the Essential Health and Safety Requirements has been assured by compliance with:

EN 60 079-0:2006

EN 60079-11:2007

EN 60079-26:2007

(10) If the sign "X" is placed after the certificate number, it indicates that the equipment or protective system is subject to special conditions for safe use specified in the schedule to this certificate.

(11) This EC-type examination certificate relates only to the design, examination and tests of the specified equipment in accordance to the Directive 94/9/EC. Further requirements of the Directive apply to the manufacturing process and supply of this equipment. These are not covered by this certificate.

(12) The marking of the equipment or protective system must include the following:

 **II 1 Ga Ex ia IIC T4 resp. II 2 Gb Ex ia IIC T4...T6**

TÜV NORD CERT GmbH, Langemarckstraße 20, 45141 Essen, accredited by the central office of the countries for safety engineering (ZLS), Ident. Nr. 0044, legal successor of the TÜV NORD CERT GmbH & Co. KG Ident. Nr. 0032

The head of the certification body

Schwedt

Hanover office, Am TÜV 1, 30519 Hannover, Fon +49 (0)511 986 1455, Fax +49 (0)511 986 1590

This certificate may only be reproduced without any change, schedule included.
Excerpts or changes shall be allowed by the TÜV NORD CERT GmbH

(13) **SCHEDULE**

(14) **EC-Type Examination Certificate No. TÜV 09 ATEX 374581**

(15) Description of equipment

The measuring transmitter type VISY-Reed ... is used for liquid detection in hazardous explosive areas.

The permissible ambient temperature ranges in dependence of the temperature class have to be taken from the following tables:

Use as Kategorie 1 apparatus

Temperature class	Ambient temperature range
T4	-20 °C to +60 °C

The process pressure of the media has to be from 0.8 bar to 1.1 when potentially explosive mist air mixtures exit. If no potential explosive mixtures exist, the device may also be operated outside of this stated range according to the specification of the manufacturer.

Use as Kategorie 2 apparatus

Temperature class	Ambient temperature range
T4	-40 °C to +75 °C
T5	-40 °C to +65 °C
T6	-40 °C to +50 °C

Electrical data

Signal- and powercircuit
(terminals +; A; B; -)

in type of protection "Intrinsic Safety" Ex ia IIC/IIB
only for the connection to a certified intrinsically safe circuit

Maximum values: $U_i = 15 \text{ V}$
 $I_i = 60 \text{ mA}$
 $P_i = 100 \text{ mW}$
 $L_i = 120 \text{ }\mu\text{H}$
 $C_i = 10 \text{ nF}$

(16) Test documents are listed in the test report No. 09203374581.

(17) Special conditions for safe use

none

(18) Essential Health and Safety Requirements

no additional ones

Translation
1. SUPPLEMENT

to Certificate No. TÜV 09 ATEX 374581

Equipment: Environmental Sensor for Leakage Detection type VISY-Reed ...

Manufacturer: FAFNIR GmbH

Address: Bahrenfelder Straße 19
22765 Hamburg
Germany

Order number: 8000441810

Date of issue: 2015-01-14

Amendments:

In the future, the environmental sensors type VISY-Reed ... may also be manufactured according to the test documents listed in the test report.

The amendments concern the ambient temperature range as well as the "Electrical Data".

Also the equipment was assessed according to the latest standards.

The permissible ambient temperature ranges in dependence of the temperature class have to be taken from the following tables:

Use as category 1 apparatus

Temperature class	Ambient temperature range
T6	-20 °C to +50 °C
T5 to T1	-20 °C to +60 °C

The process pressure of the media has to be from 0.8 bar to 1.1 bar when potentially explosive mist air exist. If no potential explosive mixtures exist, the devices may also be operated outside of this stated range according to the specification of the manufacturer.

Use as category 2 apparatus

Temperature class	Ambient temperature range
T6	-40 °C to +50 °C
T5	-40 °C to +65 °C
T4 to T1	-40 °C to +85 °C

Electrical Data

Signal and supply circuit
(terminals +, A, B, -)

in type of protection "Intrinsic Safety" Ex ia IIC/IIB
only for the connection to a certified intrinsically safe circuit

Maximum values: $U_i = 15 \text{ V}$
 $I_i = 60 \text{ mA}$
 $P_i = 100 \text{ mW}$
 $L_i = 100 \text{ }\mu\text{H}$
 $C_i = 10 \text{ nF}$

The device will then be labelled as follows:

 II 1 G Ex ia IIC T6...T5 Ga resp. II 2 G Ex ia IIC T6...T4 Gb

All other data apply unchanged for this supplement.

The equipment meets inclusive of this supplement the requirements of these standards:

EN 60079-0:2012

EN 60079-11:2012

EN 60079-26:2007

(16) Test documents are listed in the test report No. 15 203 152254.

(17) Special conditions for safe use

none

(18) Essential Health and Safety Requirements

no additional ones

TÜV NORD CERT GmbH, Langemarckstraße 20, 45141 Essen, notified by the central office of the countries for safety engineering (ZLS), Ident. Nr. 0044, legal successor of the TÜV NORD CERT GmbH & Co. KG Ident. Nr. 0032

The head of the notified body



Schwedt

Hanover office, Am TÜV 1, 30519 Hannover, Fon +49 (0)511 986 1455, Fax +49 (0)511 986 1590

9.2.3 Instructions

TÜV 09 ATEX 374581

Environmental Sensor for Leakage Detection type VISY-Reed

Edition: 11.2014

I Range of application

The environmental sensors VISY-Reed ... serve as level detectors in potentially explosive areas. A float with built-in magnet slides on the sensor tube. It closes or opens a reed contact. A microcontroller evaluates the contacts and can trigger an alarm in both the open and the closed state.

II Standards

The equipment is designed in accordance with the following European standards

EN 60079-0:2012	Equipment – General Requirements
EN 60079-11:2012	Equipment protection by intrinsic safety "i"
EN 60079-26:2007	Equipment with Equipment Protection Level (EPL) Ga

III Instructions for safe ...

III.a ... use

The environmental sensors are designed as intrinsically safe equipment and are suitable for use in potentially explosive areas. The environmental sensors may be used for all gas groups (IIA, IIB and IIC).

The approval applies to the device versions

- VISY-Reed Interstitial Dry
- VISY-Reed Interstitial Wet
- VISY-Reed Sump Dispenser
- VISY-Reed Sump Manhole

III.b ... assembling and dismantling

The housing of the environmental sensor must not be opened! Disassembly may damage the environmental sensor and its approval expires.

III.c ... installation

The wiring must be carried out only with the power disconnected. Special rules and regulations, including EN 60079-14 and local installation regulations, must be observed.

When wiring the sensor to the measuring transducer (preferably blue coloured cable), the approved inductance and capacitance of the associated equipment must not be exceeded. The terminals of the sensor must be connected to the same terminals of the measuring transducer. The environmental sensors can also be connected parallel to the level sensor VISY-Stick ...

Pin assignment:

Description	Abbreviation	Colour
Power supply +	+	brown
Power supply -	-	blue
Communication A	A	white
Communication B	B	black

Table III.c: Pin assignment of environmental sensors with integrated cable

To integrate the environmental sensors into the equipotential bonding, a PA terminal is provided on the sensor head.

III.d ... adjustment

No Ex-relevant adjustments are required for operating the Environmental sensors.

III.e ... putting into service



Before putting into service, all devices must be checked of right installation and connection. The electrical supply, as well of connected devices, must be checked.

III.f ... maintenance, overhaul and repair

The environmental sensors are generally maintenance-free. In case of a defect, it must be send back to FAFNIR or one of its representations.

The unit complies with the dielectric strength requirements as set out in EN 60079-11, clause 6.3.13.

IV Equipment marking

- 1 Manufacturer: FAFNIR GmbH, Hamburg
- 2 Type designation: VISY-Reed ...
- 3 Serial number: Ser. N°: ...
- 4 Certificate number: TÜV 09 ATEX 374581
- 5 Ex-marking:

II 1 G Ex ia IIC T6...T5 Ga
II 2 G Ex ia IIC T6...T4 Gb
- 6 CE marking: 0044
- 7 Technical data:
 $-20\text{ °C} \leq T_a(\text{Ga}) \leq +50\text{ °C}_{T6} / +60\text{ °C}_{T5}$
 $-40\text{ °C} \leq T_a(\text{Gb}) \leq +50\text{ °C}_{T6} / +65\text{ °C}_{T5} / +85\text{ °C}_{T4}$
 $U_i \leq 15\text{ V}$
 $I_i \leq 60\text{ mA}$
 $P_i \leq 100\text{ mW}$
 $L_i < 100\text{ }\mu\text{H}$
 $C_i < 10\text{ nF}$

V Technical data

The following electrical input values apply to the environmental sensors:

Input voltage	$U_i \leq 15 \text{ V}$
Input current	$I_i \leq 60 \text{ mA}$
Input power	$P_i \leq 100 \text{ mW}$
Internal capacitance	$C_i < 10 \text{ nF}$
Internal inductance	$L_i < 100 \text{ }\mu\text{H}$

When used in potentially gas explosive atmospheres, please consult table 5 for the maximum temperatures depending on temperature classes and categories / equipment protection levels.

Temperature class	T_a
Category 1 or equipment protection level Ga (environmental sensor installed in Zone 0)	
T6	-20 °C ... +50 °C
T5, T4, T3, T2, T1	-20 °C ... +60 °C
Category 2 or equipment protection level Gb (environmental sensor installed in Zone 1)	
T6	-40 °C ... +50 °C
T5	-40 °C ... +65 °C
T4, T3, T2, T1	-40 °C ... +85 °C

Table V: Maximum temperatures of environmental sensors

For use in areas where the equipment protection level Ga is required, the following applies:

The process pressure for the media must be between 0.8 bar and 1.1 bar where explosive vapour-air mixtures are present. If no explosive mixtures are present, the equipment may also be operated outside this area according to the manufacturer's specification.

General information (see also EN 60079-0, section 1):

Zone 0 exists only under atmospheric conditions:

Temperature range: -20 °C ... +60 °C

Pressure range: 0.8 bar to 1.1 bar

Oxidants: Air (oxygen content approx. 21 %)

The transmitter achieves a housing protection rating of:

Degree of protection IP68

VI Specific conditions for use

None.

9.3 Technical Data

- The VISY-Stick and VISY-Reed sensors are approved for use in potentially explosive atmospheres, see Certificates.
- For details on explosion protection, permissible ambient temperature (probe head), and the connection data please refer to the approvals and operating instructions.
- With a battery-powered radio transmitter, all sensors can be used as wireless versions.
- All sensors have protection class IP68 according to EN 60529 (IPX8: Immersion depth of 2 metres for 30 days).

For further technical data see:



VISY-Stick VISY-Reed Data (multilingual), art. no. 350105

Blank page



Blank page

Blank page



FAFNIR GmbH
Schnackenburgallee 149 c
22525 Hamburg, Germany
Tel.: +49 / 40 / 39 82 07-0
E-mail: info@fafnir.com
Web: www.fafnir.com
