

LS 300

Level detector

LS 500

Measuring transducer



Edition: 2021-11

Version: 10

Art. No. 207057

Contents

1	Characteristics.....	1
2	Safety instructions.....	1
3	System application	2
3.1	Application as overfill protection device	2
3.2	Application as limit signal controller.....	2
3.3	Application as dry-run protection.....	2
3.4	Use of the LS 500 H with RS-485 interface	3
3.5	Wiring	5
3.6	LED status indication and blink codes.....	6
	Annex	7
	EU Declaration of Conformity LS 300	7
	EU Declaration of conformity LS 500.....	8
	Approval principles for overfill protection devices.....	9
	Appendix 1: Adjustment instructions for overfill protection of containers.....	9
	1. General.....	9
	2. Permissible filling degree	9
	3. Determining the overrun quantity after response of the overfill protection	10
	4. Defining the response level for the overfill protection device	10
	Appendix 2: Installation and operating instructions for overfill protection	12
	1. Scope.....	12
	2. Definitions.....	12
	3. Design of overfill protection devices.....	12
	4. Installation and operation.....	13
	5. Tests.....	14
	Technical description Z-65.11-228.....	15
	1. Design of the overfill protection system	15
	2. Material of level detectors.....	22
	3. Area of application	22
	4. Fault and error messages.....	23
	5. Installation notes.....	23
	6. Setting instructions.....	25

7. Instructions	26
8. Periodic inspection.....	26
General construction approval (German DIBt).....	28
EU-Type Examination Certificate - LS 300	35
Instructions in accordance with directive 2014/34/EU – TÜV 00 ATEX 1656 X	38
EU-Type Examination Certificate - LS 500	41
Instructions in accordance with directive 2014/34/EU – TÜV 00 ATEX 1641 X	45
SIL2 Certificate according to EN61508 – LS 300 ... with LS 500 H SIL	49
SIL2 Safety Guide – LS 300 ... with LS 500 H SIL	53

© Copyright:

Reproduction and translation are permitted only with the written consent of the FAFNIR GmbH. The FAFNIR GmbH reserves the right to make product alterations without prior notice.

1 Characteristics

The level detector type LS 300 ... with measuring transducer type LS 500 ... is a safety device designed to prevent overflowing of tanks and process vessels by continuous monitoring.

This safety device is used for all storage containers with liquids. It consists of a level detector in the tank and a measuring transducer (wall mounting, mounting rail, 19" system) with potential-free relay output.

The level detector can be customised easily to the respective container size. The safety device is maintenance-free.

2 Safety instructions

The level detector type LS 300 ... with measuring transducer type LS 500 ... is designed for monitoring liquids in tanks and process vessels. The devices must be used exclusively for this purpose. The manufacturer accepts no liability for any form of damage resulting from improper use.

The system has been developed, manufactured and tested in accordance with state-of-the-art technology and generally accepted safety standards. Nevertheless, hazards may arise from its use. For this reason, the following safety instructions must be observed:

- Do not change or modify the system or add any equipment without the prior consent of the manufacturer.
- The installation, operation and maintenance of the system must be carried out only by expert personnel. Specialised knowledge must be acquired by regular training.
- Operators, installers and service technicians must comply with all applicable safety regulations. This also applies to any local safety and accident prevention regulations which are not stated in this technical documentation.
- During level detector installation, the probe must not be sited in a position exposed to powerful vapour flow unless it is equipped with a suitably dimensioned protective sleeve.
- The measuring transducer must not be operated in an explosion-risk area and must be installed in an enclosed room or in a housing complying with protection class IP54.
- The design of the plug-in card of the measuring transducer LS 500 19" is to be installed in a housing with protection class of at least IP20.
- Following completion of the installation and in the event of a change of liquid stored in the container, the system must be checked for correct installation and tested for correct operation by an expert of a specialist company.

- The operability of electrical circuits for sirens and lamps that cannot operate in accordance with the closed-circuit principle must be easy to inspect.
- Before commissioning, all system parts of the overflow protection device must be checked to determine that they are correctly connected and working properly. The electrical supply, as well as downstream devices, must be checked.
- When used as overflow protection, untested system parts must comply with the requirements of the approval principles for overflow protection devices.

In the event of a failure of the power supply (no longer within the minimum or maximum limit values) or an interruption of the connection lines between system parts, the overflow protection devices are required to report this fault or display the maximum fill level.

The safety instructions in this user guide are marked as follows:



If you do not comply with the safety instructions, there is a risk of accident, or the system/device may be damaged.



Useful information which ensures continued and correct operation of the system and makes your work easier.

3 System application

3.1 Application as overflow protection device

For details on using the LS 300 ... level detector with LS 500 ... measuring transducer as overflow protection, see chapter Technical description Z-65.11-228, page 15.

3.2 Application as limit signal controller

The function of the LS 300 ... level detector with LS 500 ... measuring transducer as limit signal controller is analogous to that of the overflow protection. See chapter Technical description Z-65.11-228, page 15.



The use as limit signal controller does not replace the overflow protection device. If an overflow protection device is mandatory, it must additionally be installed.

3.3 Application as dry-run protection

The function of the LS 300 ... level detector with LS 500 ... measuring transducer as dry run protection is analogous to that of the overflow protection, whereby the LS 300 ... probe is usually immersed and exposed in the event of an alarm. See chapter Technical description Z-65.11-228, page 15.

LS 500 ... T ...

A relay drop occurs when the level detector tip is hot, in the event of a malfunction, power failure, short circuit or line break in the connection between level detector and measuring transducer. This is indicated by turning OFF the yellow LED (sensor).

LS 500 ... H SIL T

This type offers additional functional safety.

LS 500 ... T Duo

These types allow the connection of two level detectors. With the LS 500 19" T Duo, the two sensor circuits are galvanically isolated from each other.

LS 500 ... T S

With these types, one error relay and one red LED (Error) are available. In case of interruption or short-circuit of the signal line from the level detector to the measuring transducer, the relay energizes, and the LED is ON.

LS 500 ... T Z

With these types, a second sensor relay is available.

3.4 Use of the LS 500 H with RS-485 interface

The measuring transducer LS 500 H ... offers an RS-485 interface which allows to connect several LS 500 H ... to a multi-drop network and to read the status of the scanner and relay by digital requests. For this, the binary MODBUS RTU protocol is used.

Specification of the RS-485 interface	
Conductors	A+ / B- / GND
Voltage	0 V ... 5 V
Baud rate	9600
Bits	8
Parity	None
Stop bits	1

Request device status

The status of scanner, fault detection and the relay are read via the Read Holding Registers function (03h). The data are located in both registers from address 40033 (0020h). If only one device is connected, broadcast address 00h can be used.

Command as sequential order of bytes:

[ADDR]	[FUNC]	[REG/H]	[REG/L]	[VAL/H]	[VAL/L]	[CRC/H]	[CRC/L]
XXh / 00h	03h	00h	20h	00h	02h	XXh	XXh
MODBUS address or broadcast 00h	Function 03h: Read Holding Registers	Register address High Byte	Register address Low Byte	Data length High Byte	Data length Low Byte	MODBUS Checksum High Byte	MODBUS Checksum Low Byte

Answer as sequential order of bytes:

[ADDR]	[FUNC]	[BC]	[R1/H]	[R1/L]	[R2/H]	[R2/L]	[CRC/H]	[CRC/L]
XXh	03h	04h	XXh	XXh	XXh	XXh	XXh	XXh
MODBUS address or broadcast 00h	Function 03h: Read Holding Registers	Byte Count	Register 40033 High Byte	Register 40033 Low Byte	Register 40034 High Byte	Register 40034 Low Byte	MODBUS Checksum High Byte	MODBUS Checksum Low Byte

The information about the current status of the sensor are in the 4 bytes of R1 and R2. Each byte contains precisely 2 types of information that are split up between the nibbles (4-bit values).

The information on relay 2 is then dependent on the type of the respective LS 500 H ... In case of Z versions, it responds analogous to relay 1, in case of duo versions it is switched by sensor 2. For both versions, an energized relay indicates the readiness of the respective sensor. In case of S versions, an energized relay signals an existing malfunction.

Register	[R1/H]		[R1/L]	
Nibble	High nibble	Low nibble	High nibble	Low nibble
Values	0 ... 2	0 / 1		
Function	Status of sensor 1 0: No fault 1: Short-circuit 2: Connection open	Status of sensor 1 0: Cooling 1: Heating	Status of sensor 1 0: Immersed or in heating phase 1: Not immersed	Status of relay 1 0: De-energized 1: Energized

Register	[R2/H]		[R2/L]	
Nibble	High nibble	Low nibble	High nibble	Low nibble
Values	0 ... 2	0 / 1		
Function	Status of sensor 2 0: No fault 1: Short-circuit 2: Connection open	Status of sensor 2 0: Cooling 1: Heating	Status of sensor 2 0: Immersed or in heating phase 1: Not immersed	Status of relay 2 0: De-energized 1: Energized

Setting the MODBUS address

The MODBUS address is set via the Preset Single Register (06h) function. The address (1 – 99) is written as 16-bit value into register 40002 (0001h).

To set the address either the current address must be known or the broadcast address 00h must be used. In this case only 1 device is permitted to be connected with the data bus.

Command as sequential order of bytes:

[ADDR]	[FUNC]	[REG/H]	[REG/L]	[VAL/H]	[VAL/L]	[CRC/H]	[CRC/L]
XXh / 00h	06h	00h	01h	00h	01h - 99h	XXh	XXh
MODBUS address or broadcast 00h	Function 06h: Preset Single Register	Register address High Byte	Register address Low Byte	Write value High Byte	Write value Low Byte	MODBUS Checksum High Byte	MODBUS Checksum Low Byte

Answer as sequential order of bytes:

[ADDR]	[FUNC]	[REG/H]	[REG/L]	[VAL/H]	[VAL/L]	[CRC/H]	[CRC/L]
XXh	06h	00h	01h	00h	01h - 99h	XXh	XXh
MODBUS address	Function 06h: Preset Single Register	Register address High Byte	Register address Low Byte	Write value High Byte	Write value Low Byte	MODBUS Checksum High Byte	MODBUS Checksum Low Byte

3.5 Wiring

The wiring of the level detector to the measuring transducer must be done with a cable in blue or blue marked colour. The maximum admissible cable length with a cross-section of 0.5 mm² is 250 m, with 1 mm² a maximum of 500 m and with 1.5 mm² a maximum of 750 m. Deviating cross-sections result in a different maximum cable length.

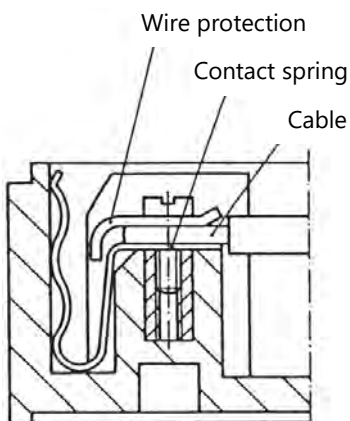

Figure 1: Cable fanning

3.6 LED status indication and blink codes

LED	STATUS					
	Overfill protection		Dry run protection		Error	SIL Error ²⁾
	Normal operation	Alarm	Normal operation	Alarm		
	not immersed	immersed	immersed	not immersed		
Power (green)	ON	ON	ON	ON	ON	ON
Sensor (yellow)	ON	OFF	ON	OFF	OFF	OFF
Scanner (blue)	blinking	ON	ON	blinking	OFF	OFF
Error (red) ¹⁾	OFF	OFF	OFF	OFF	ON	blinking
SIL Error (red) ²⁾	OFF	OFF	OFF	OFF	OFF	ON

All codes are valid for all types of LS 500 with the exception of:

1) **not** available on the LS 500 H DUO

2) **only** available on the LS 500 H SIL

LED blink codes of the LS 500 H SIL for SIL Errors

Blink code	Description
1 x	Memory error
2 x	Checksum error
3 x	Relay error
4 x	Resistor error
5 x	Scanner error
6 x	Isolation error



**EU-Konformitätserklärung
EU Declaration of Conformity
Déclaration UE de Conformité
Dichiarazione di Conformità UE**



FAFNIR GmbH, Deutschland / Germany / Allemagne / Germania

erklärt als Hersteller in alleiniger Verantwortung, dass die Produkte
declares as manufacturer under sole responsibility that the products
déclare sous sa seule responsabilité en qualité de fabricant que les produits
dichiara sotto la sola responsabilità del produttore, che i prodotti sono

**Grenzwertgeber bzw. Standaufnehmer bzw. Aufstausensor /
Overfill Prevention Sensor resp. Level Detector resp. High Level Sensor /
Capteurs de valeur limite resp. Détecteur de niveau resp. Capteur de niveau haut /
Sensore di troppo pieno o rivelatore di livello o sensore di alto livello
81 D-Ex ... & 83 UV-... / 76 ... & LS 300 ... / SEPARIX-T ...**

den Vorschriften der europäischen Richtlinien
comply with the regulations of the European directives
sont conformes aux réglementations des directives européennes suivantes
rispetta i regolamenti delle direttive europee

2011/65/EU	Beschränkung der Verwendung bestimmter gefährlicher Stoffe in Elektro- und Elektronikgeräten	RoHS
2011/65/EU	Restriction of the use of certain hazardous substances in electrical and electronic equipment	RoHS
2011/65/UE	Limitation de l'utilisation de certaines substances dangereuses dans les équipements électriques et électroniques	RoHS
2011/65/UE	Restrizione dell'uso di determinate sostanze pericolose nelle apparecchiature elettriche ed elettroniche	RoHS
2014/34/EU	Geräte und Schutzsysteme zur bestimmungsgemäßen Verwendung in explosionsgefährdeten Bereichen	ATEX
2014/34/EU	Equipment and protective systems intended for use in potentially explosive atmospheres	ATEX
2014/34/UE	Appareils et systèmes de protection destinés à être utilisés en atmosphères explosibles	ATEX
2014/34/UE	Apparecchi e sistemi di protezione destinati a essere utilizzati in atmosfera potenzialmente esplosiva	ATEX

durch die Anwendung folgender harmonisierter Normen entsprechen
by applying the harmonised standards
par l'application des normes
applicando le norme armonizzate

**RoHS / RoHS / RoHS / RoHS
ATEX / ATEX / ATEX / ATEX**

**EN IEC 63000:2018
EN IEC 60079-0:2018
EN 60079-11:2012
EN 60079-26:2015**

Die Produkte sind bestimmt als Elektro- und Elektronikgeräte der RoHS-
The products are determined as electrical and electronic equipment of RoHS
Les produits sont déterminés comme des équipements électriques et électroniques de RoHS
I prodotti sono determinati come apparecchiature elettriche ed elettroniche della RoHS

Kategorie / Category / Catégorie / Categoria

**Überwachungs- und Kontrollinstrumenten in der Industrie /
Industrial Monitoring and Control Instruments /
Instruments de contrôle et de surveillance industriels /
Strumenti di monitoraggio e controllo industriali**

Die notifizierte Stelle TÜV NORD CERT GmbH, 0044 hat eine EU-Baumusterprüfung durchgeführt und folgende Bescheinigung ausgestellt
The notified body TÜV NORD CERT GmbH, 0044 performed a EU-type examination and issued the certificate
L'organisme notifié TÜV NORD CERT GmbH, 0044 a effectué examen UE de type et a établi l'attestation
L'organismo notificato TÜV NORD CERT GmbH, 0044 ha effettuato esame UE del tipo e rilasciato il certificato

81 D-Ex ... & 83 UV-... / LS 300 ... / SEPARIX-T ...

TÜV 00 ATEX 1656 X

Hamburg, 15.11.2021

Ort, Datum / Place, Date / Lieu, Date / Luogo, data

Geschäftsführer / Managing Director / Gérant / Direttore Generale: René Albrecht



**EU-Konformitätserklärung
EU Declaration of Conformity
Déclaration UE de Conformité
Dichiarazione di Conformità UE**



FAFNIR GmbH, Deutschland / Germany / Allemagne / Germania

erklärt als Hersteller in alleiniger Verantwortung, dass das Produkt
declares as manufacturer under sole responsibility that the product
déclare sous sa seule responsabilité en qualité de fabricant que le produit
dichiara sotto la sola responsabilità del produttore, che il prodotto

**Messumformer / Measuring Transducer / Transducteur de mesure / Trasduttore di misura
LS 500 ...**

den Vorschriften der europäischen Richtlinien
complies with the regulations of the European directives
est conforme aux réglementations des directives européennes suivantes
è conforme ai regolamenti delle direttive europee

2011/65/EU	Beschränkung der Verwendung bestimmter gefährlicher Stoffe in Elektro- und Elektronikgeräten	RoHS
2011/65/EU	Restriction of the use of certain hazardous substances in electrical and electronic equipment	RoHS
2011/65/UE	Limitation de l'utilisation de certaines substances dangereuses dans les équipements électriques et électroniques	RoHS
2011/65/UE	Restrizione dell'uso di determinate sostanze pericolose nelle apparecchiature elettriche ed elettroniche	RoHS
2014/30/EU	Elektromagnetische Verträglichkeit	EMV
2014/30/EU	Electromagnetic compatibility	EMC
2014/30/UE	Compatibilité électromagnétique	CEM
2014/30/UE	Compatibilità elettromagnetica	CEM
2014/34/EU	Geräte und Schutzsysteme zur bestimmungsgemäßen Verwendung in explosionsgefährdeten Bereichen	ATEX
2014/34/EU	Equipment and protective systems intended for use in potentially explosive atmospheres	ATEX
2014/34/UE	Appareils et systèmes de protection destinés à être utilisés en atmosphères explosibles	ATEX
2014/34/UE	Apparecchi e sistemi di protezione destinati a essere utilizzati in atmosfera potenzialmente esplosiva	ATEX

durch die Anwendung folgender harmonisierter Normen entspricht
by applying the harmonised standards
par l'application des normes
applicando le norme armonizzate

RoHS / RoHS / RoHS / RoHS	EN IEC 63000:2018
EMV / EMC / CEM / CEM	EN 61326-1:2013
ATEX / ATEX / ATEX / ATEX	EN IEC 60079-0:2018
	EN 60079-11:2012

Das Produkt ist bestimmt als Elektro- und Elektronikgerät der RoHS-
The product is determined as electrical and electronic equipment of RoHS
Le produit est déterminé comme des équipements électriques et électroniques de RoHS
Il prodotto è determinato come apparecchiatura elettrica ed elettronica di RoHS

Kategorie / Category / Catégorie / Categoria	Überwachungs- und Kontrollinstrumenten in der Industrie / Industrial Monitoring and Control Instruments / Instruments de contrôle et de surveillance industriels / Strumenti di monitoraggio e controllo industriali
---	---

Das Produkt entspricht den EMV-Anforderungen
The product complies with the EMC requirements
Le produit est conforme aux exigences CEM
Il prodotto è conforme ai requisiti CEM

Störaussendung / Emission / Émission / L'emissione	Klasse B / Class B / Classe B / Classe B
Störfestigkeit / Immunity / D'immunité / Immunità	Industrielle elektromagnetische Umgebung / Industrial electromagnetic environment / Environnement électromagnétique industriel / Ambiente elettromagnetico industriale

Die notifizierte Stelle TÜV NORD CERT GmbH, 0044 hat eine EU-Baumusterprüfung durchgeführt und folgende Bescheinigung ausgestellt
The notified body TÜV NORD CERT GmbH, 0044 performed a EU-type examination and issued the certificate
L'organisme notifié TÜV NORD CERT GmbH, 0044 a effectué examen UE de type et a établi l'attestation
L'organismo notificato TÜV NORD CERT GmbH, 0044 ha effettuato esame UE del tipo e rilasciato il certificato

LS 500 ...

TÜV 00 ATEX 1641 X

Hamburg, 27.08.2021

Ort, Datum / Place, Date / Lieu, Date / Luogo, data

Geschäftsführer / Managing Director / Gérant / Direttore Generale: René Albrecht

Approval principles for overfill protection devices

Appendix 1: Adjustment instructions for overfill protection of containers

1. General

The following requirements are necessary for the correct adjustment of the overfill protection device:

- Knowledge of the filling height at 100% of the filling volume of the container according to the nominal volume stated on the type plate of the container
- Knowledge of the filling curve
- Knowledge of the filling height that corresponds to the permissible filling degree
- Knowledge of the level change related to the expected overrun quantity.

2. Permissible filling degree

- (1) The permissible filling degree of containers is to be so dimensioned that the container cannot overflow and that excess pressures, which can impair the leak-proof tightness or solidity of the container, does not arise.
- (2) When defining the permissible filling degree, the cubic expansion coefficient of the liquid relevant for the filling of a container and the possible rise in temperature during storage and a resultant increase in the volume of the liquid is to be taken into consideration.
- (3) For the storage of liquids in stationary containers without additional hazardous characteristics, the permissible filling degree at filling temperature is to be defined as follows:
 1. For above-ground and below-ground containers that are embedded less than 0.8 m below ground level is the
Filling degree = $\frac{100}{1+\alpha \cdot 35}$ in % of the volumetric capacity
 2. For below-ground containers at a depth of at least 0.8 m is the
Filling degree = $\frac{100}{1+\alpha \cdot 20}$ in % of the volumetric capacity
 3. The average cubic expansion coefficient α can be determined as follows:
$$\alpha = \frac{d_{15} - d_{50}}{35 \cdot d_{50}}$$

Here, d_{15} or d_{50} means the density of the fluid at 15 °C or 50 °C.

- (4) Paragraph (1) can also be considered as having been met for liquids independent of a flash point without additional hazardous characteristics and whose cubic expansion coefficient does not exceed $150 \cdot 10^{-5}/K$, if the filling degree at filling temperature
 - a) for above-ground and below-ground containers which lie less than 0.8 m below ground level does not exceed 95%, and
 - b) for below-ground containers which lie at a depth of at least 0.8 m does not exceed 97% of its volumetric capacity.
- (5) If the liquid is heated to above 50°C during storage, or it is filled in a cooled-down state, also the related expansions need to be considered when defining the filling degree.
- (6) In the case of containers used for storing liquids with toxic or corrosive characteristics, a filling degree of 3% less than that according to section (3) to (5) should be adhered to.

3. Determining the overrun quantity after response of the overfill protection

Maximum volumetric flow rate of delivery pump

The maximum volumetric flow rate can either be determined by gauging (recirculating a defined liquid volume) or referenced from the pump characteristic curve. On containers conforming to DIN 4119, the permissible volumetric flow rate is stated on the container information plate.

Shutdown delay times

- (1) To the extent that the response times, switching times and operating times of individual parts are not stated on the associated data sheets, these times shall be measured.
- (2) Where valves require manual operation to interrupt the filling process, the time between the response of the overfill protection device and the interruption of the filling process shall be estimated under consideration of local conditions.

Overrun quantity

The sum of individual shutdown delay times gives the overall shutdown delay time. The overrun quantity is obtained by multiplying the overall shutdown delay time by the volumetric flow rate determined in accordance with section 3.1 and adding the capacity of the pipes that would be drained following the response of the overfill protection device.

4. Defining the response level for the overfill protection device

The overrun quantity determined in accordance with section 3.3 is subtracted from the volume of liquid that corresponds to the permissible filling degree. The response level is determined from the difference and the aid of the filling curve by means of calculation or gauging the capacity of the container in litres. The determination is to be documented.

Calculating the response level for overflow protection devices

Operating location: _____
 Container no.: _____ Nominal volume: _____ (m³)
 Overflow protection device: Manufacturer / Type: **FAFNIR GmbH / LS 300** **with LS 500**
 License no.: **Z-65.11-228**

1 Maximum volumetric flow rate (Q_{max}): _____ (m³/h)

2 Shutdown delay times

2.1 Level detector according to measurement / data sheet: _____ (s)

2.2 Switches / relays / or similar: _____ (s)

2.3 Cycle times for bus devices and control instrumentation: _____ (s)

2.4 Delivery pump, run-out time: _____ (s)

2.5 Shut-off valve
 mechanically, manually actuated
 - Time from alarm / to start of shutdown: _____ (s)
 - Shutdown time: _____ (s)

Electrically, pneumatically or hydraulically operated
 - Shutdown time: _____ (s)

Overall shutdown delay time (t_{total}): _____ (s)

3 Oerrun quantity (V_{total})

3.1 Oerrun quantity from overall shutdown delay time:
 $V_1 = Q_{max} \cdot \frac{t_{ges}}{3.600} =$ _____ (m³)

3.2 Oerrun quantity from pipes:
 $V_2 = \frac{\pi}{4} \cdot d^2 \cdot L =$ _____ (m³)

Total oerrun quantity (V_{total} = V₁ + V₂): _____ (m³)

4 Response level

4.1 Volume at permissible filling degree: _____ (m³)

4.2 Oerrun quantity: _____ (m³)

Volume at response level (difference between 4.1 and 4.2): _____ (m³)

The response level results from the filling curve,
 calculation or gauging the capacity of the container in litres: _____ (mm)

Appendix 2: Installation and operating instructions for overflow protection

1. Scope

This installation and operating guideline applies to setup and operate overflow protection devices comprised of multiple parts.

2. Definitions

- (1) Overflow protection devices are designed to interrupt the filling process or trigger an audible and visual alarm promptly before the permissible filling degree in the container is reached (for calculating the response level see Appendix 1).
- (2) Overflow protection devices include all parts needed to affect the interruption of the filling process or trigger the alarm.
- (3) Aside from parts with German general construction approval (DIBT), overflow protection devices can also include parts without this approval. Figure 1 shows the parts requiring approval (parts on the left of the dividing line).
- (4) Atmospheric conditions are considered to be total pressures of 0.08 MPa to 0.11 MPa = 0.8 bar to 1.1 bar and temperatures of -20 °C to +60 °C.

3. Design of overflow protection devices

(see Figure 1 of the Approval principles for overflow protection devices or Appendix 1 of the General construction approval, DIBt)

- (1) Level detector (1) records the liquid level in the container.
- (2) The liquid level is converted to a level-proportional output signal by a continuous level gauging device in the associated measuring transducer (2), e.g. to an industry-standard signal (e.g. pneumatic 0.02 MPa to 0.10 MPa = 0.2 bar to 1.0 bar or electrical 4 ... 20 mA or 2 ... 10 V or digital via a suitable bus interface). The proportional output signal is supplied to a limit signal transducer (3), which compares the signal to the adjustable limit values and delivers binary output signals.
- (3) At level limit switches, the liquid level is converted to a binary output signal in the level detector (1) or in the associated measuring transducer (2) or transmitted as digital signals to a suitable bus interface.
- (4) Signals can be conducted, for example, via pneumatic or electric contacts (switches, electronic switching circuits, initiator circuits) or as digital signals for bus interfaces.
- (5) The binary output signal of the measuring transducer (2) or of the limit signal transducer (3) or the bus communication signals of the measuring transducer (2) can be supplied to the signalling device (5a) or to control device (5b) with actuator (5c) either directly or via suitable evaluation devices / signal amplifier (4).
- (6) The proportional (analogue) or binary output signal can also be evaluated via suitable electronic switching circuits (e.g. PLC, process control systems).

4. Installation and operation

4.1 Fault monitoring

- (1) In the event of a failure of the power supply or an interruption in the connecting lines between parts or failure of the bus communication, overfill protection devices must interrupt the filling process or trigger an audible and visual alarm.
In the case of overfill protection devices in accordance with the approval principles, this can be achieved by the measures defined according to sections (2) to (4), in which case the conditions for monitoring of operability are also fulfilled.
- (2) Overfill protection devices shall as a rule be safeguarded in accordance with the closed-circuit principle or other measures appropriate to fault monitoring.
- (3) Overfill protection devices with level limit switch of which the binary output constitutes an initiator circuit with standardised interface shall be connected to a repeater in accordance with DIN EN 60947-5-6. The direction of action of the repeater shall be selected such that, in the event of a power supply failure or a line break in the control circuit, its output signal interrupts the filling process or triggers an audible and visual alarm.
- (4) Electric circuits for audible and visual alarms that cannot operate in accordance with the closed-circuit principle must be easy to inspect in terms of their functionality.

4.2 Control air

The control air required as auxiliary power must not contain contamination with a particle size of $> 100 \mu\text{m}$ and must have a humidity corresponding to a dew point of $-25 \text{ }^\circ\text{C}$.

4.3 Specialist companies

Only companies that satisfy the definition of a company specialised in the installation, servicing, repair and cleaning of the overfill protection devices according to water right shall be entrusted with these tasks, unless the tasks are exempted from the specialist company obligation according to the law concerning water or the manufacturer of the level detectors and measuring transducers has the tasks undertaken by its own expert personnel.

5. Tests

5.1 Test prior to initial commissioning and re-commissioning after shutdown

Following the completion of the installation of the overfill protection device or re-commissioning of the container after shutdown, the system must be checked for correct installation and tested for correct operation by an expert of the specialist company according to section 4.3, or of the operating company if there is no specialist company obligation.

If a change in the settings is expected during a change in the liquid stored, such as the response level or the function, a new function check is to be carried out.

A certificate with confirmation of the correct function is to be issued by the expert and submitted to the operating company about the setting of the overfill protection device.

5.2 Periodic inspection

(1) The proper condition and operability of the overfill protection device must be tested at reasonable intervals, but at least once a year by an expert of the specialist company according to section 4.3, or of the operating company if there is no specialist company obligation. The operating company shall be responsible for the type and frequency of inspection within the specified period. The test must be conducted in such a way that proof is obtained of correct operation of the overfill protection device with all components interacting.

- This condition can be satisfied by allowing the liquid to reach the response level during a filling process.
- If filling to the response level is not practicable,
 - the level detector should be caused to respond through simulation of the fill level or physical measuring effect or
 - if the operability of the level detector / measuring transducer is demonstrable by other means (exclusion of function-impairing faults), the test can also be carried out by simulating the corresponding output signal.

(2) If functional impairment of the overfill protection device due to corrosion cannot be prevented and this malfunction is not self-reporting, all parts that are at risk of corrosion shall also be inspected regularly at reasonable intervals.

(3) There can be a deviation from the specifications up to periodic inspection with regard to operability in case of fail-safe parts of overfill protection devices if

- components with special reliability (safe against failure) or safety relevant facilities with regard to VDI/VDE 2180 (fail-safe system) are used or this has been proved by means of an equivalent standard
- and this is expressly stated for the tested parts in the General construction approval granted by the supervising authority (in Germany DIBT).

5.3 Documentation

The results in accordance with no. 5.1 and 5.2 shall be documented and stored.

5.4 Maintenance

The operating company shall service the overfill protection device regularly to the extent that this is necessary to maintaining its operability. The recommendations of the manufacturer in this respect shall be observed.

Technical Description

Z-65.11-228

Level Detector type LS 300 ... und Measuring Transducer type LS 500 ... Edition: 08.2019

1 Design of the Overfill Protection Device

The overfill protection device comprises a level detector (1) and a measuring transducer (2) with binary signal output (potential-free relay contact).

The switching signal is supplied to the signalling device (5a) or to the control device (5b) with actuator (5c) either directly or, where necessary, by way of a signal amplifier (4).

The unchecked parts of the overfill protection device, such as signalling device (5a), control device (5b), actuator (5c) and signal amplifier (4) must satisfy the requirements of sections 3 and 4 of the German approval guidelines for overfill protection devices.

1.1 Concept of the Overfill Protection Device

Overfill protection device with level limit switch.

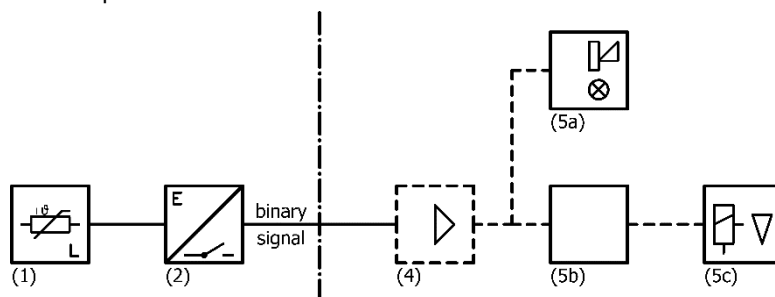

- | | | | |
|---|--------------------------------------|----|-------------------|
| 1 | Level detector type LS 300 ... | 5a | Signalling device |
| 2 | Measuring transducer type LS 500 ... | 5b | Control device |
| 4 | Signal amplifier | 5c | Actuator |

1.2 Functional description

Level detector LS 300:

The operating principle of the level detector is based on the difference in thermal conductivity between gases and liquids. A PTC resistor encapsulated in the tip of the level detector is heated in dry condition by the signal current of the measuring transducer until a sudden increase in its electrical resistance occurs. As soon as this tip is immersed in a liquid, the resulting drop in temperature causes a drop in resistance to the original value. The signal current is limited in such a way that, in this condition (immersed), the resistor cannot be reheated. In a gaseous environment, the PTC resistor takes between 15 seconds and two minutes to heat up, depending on the ambient temperature.

LS 300 ...P...: The test equipment integrated in the level detector must be connected to an external compressed air supply via plug connector or screwing. The gas required for functional testing (e.g. nitrogen) is passed through the test device directly to the PTC resistor sensor. During the blow-on process the PTC resistor is cooled down by the gas flow to the value corresponding to immersion in liquid. This activates the signalling device and the functionality of the overfill protection device is displayed.

Measuring transducer LS 500 ...:

In the measuring transducer, the changes in resistance of the PTC resistor are converted to relay switching signals with binary signal output. The PTC resistor operation is continuously monitored by a scanner integrated in the measuring transducer. The characteristics of the PTC resistor (heating and cooling behaviour) are checked several times each second without effect on the measuring process. This ensures that any PTC resistor that is no longer operationally reliable, e. g. due to external causes (corroded probe sleeve), can be detected instantly and signalled by a response of the overfill protection device's alarm system.

The electrical readiness for operation of the measuring transducer is indicated by a green LED (power). The blue LED (scanner) signals the heating up of the PTC resistor.

A relay deactivation occurs at cooled down level detector tip as well as dysfunction (detection by the scanner), power failure, short circuit and line break in the connection between level detector and measuring transducer. This is indicated by the disappearance of the yellow LED (sensor).

To control the function of the entire overfill protection device the measuring transducer can be fitted with a test button. Whenever this button is pressed, the heat output of the PTC resistor is reduced so much that it cools down (equivalent to a submerged sensor) and the alarm system is triggered.

LS 500 H Duo: This type allows the connection of two level detectors.

LS 500 ... S: For these types, a fault relay and a red LED (error) are available. In case of interruption or short-circuit of the signal line from the level detector to the measuring transducer, the relay energizes and the LED is on.

LS 500 ... Z: For these types, there is a second sensor relay available.

LS 500 H SIL: For this type, there are also a SIL error relay (changeover contact) and two red LEDs (Error and SIL Error) available. In the event of a short circuit or line break, the error LED lights up. If an error is detected by the test electronics, the SIL error relay is activated and the "SIL Error" LED lights up. In addition, the "Error" LED starts blinking.

1.3 Type codes

Level detector LS 300:

Type	Process connection	Sensor tube	Test connection	Overvoltage protection	Temperature range	Option	
LS 300						Duo	Dual sensor
						Steck	Plug connection
						Tantal	Sensor made of tantalum
						Trio	Triple sensor
						Normal	-25 °C ... +50 °C (T _a ≤ +80 °C)
						H	High -25 °C ... +80 °C
						HH	Highest -10 °C ... +110 °C
						L	Low -40 °C ... +50 °C (T _a ≤ +80 °C)
							Without overvoltage protection
						U	With (sensor head only in Zone 1 resp. EPL Gb)
							Without
						P	With test connection and without check valve
						PR	With test connection and with check valve
							Standard, e.g. Ø = 10 mm
						Bn	n = Ø in mm
S	"Heavy" version, e.g. Ø = 24 mm						
X	Flexible sensor tube						
	Without (special version)						
E	Screw-in unit						
F	Flange						
Level detector							

Table 1.3a: Type code for level detector LS 300 ...

Measuring transducer LS 500:

Type	Design	Overfill protection	Electrical design		
LS 500			One control relay (potential-free changeover contact)		
			Duo	Only H: Two sensor circuits	
			S	One additional error relay	
			Z	Second control relay	
			(Mono)	Designation "Mono" only for H and if no additions follow	
			SIL	Only mounting rail housing; with SIL 2 certificate; no further additions	
				Plug-on enclosure	
			H	Mounting rail housing with communication via RS-485	
			Measuring transducer		

Table 1.3b: Type code for Measuring transducer LS 500 ...

1.4 Dimension sheets and technical data

Level detector LS 300:

Dimensions

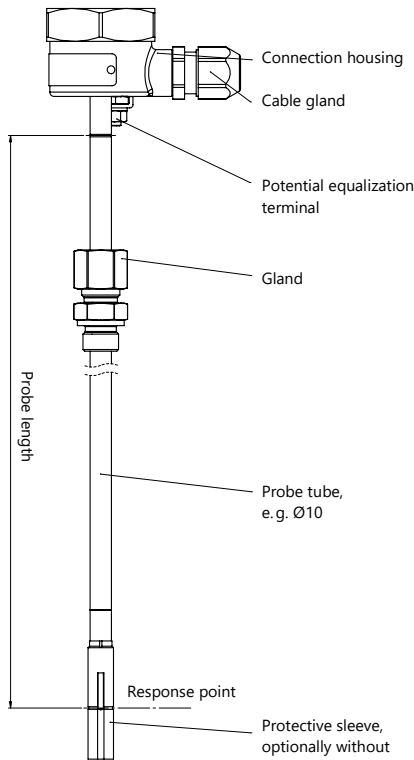

Figure 1: LS 300 E

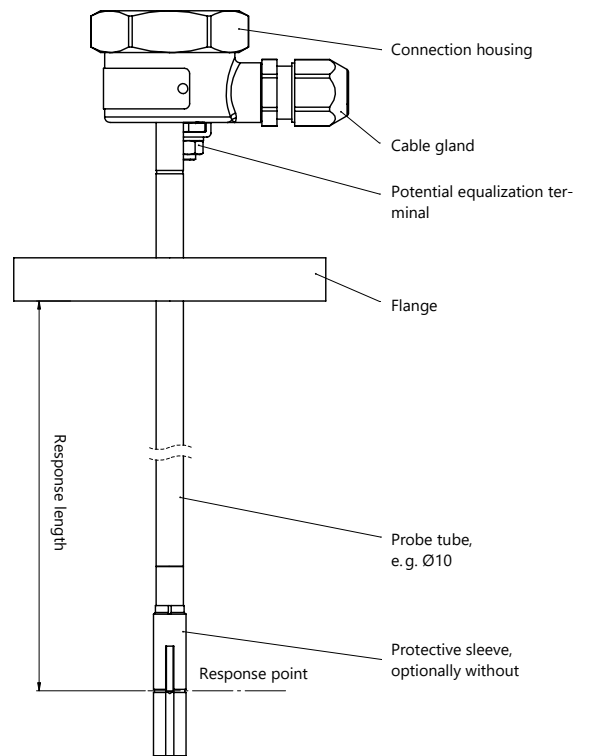

Figure 2: LS 300 F

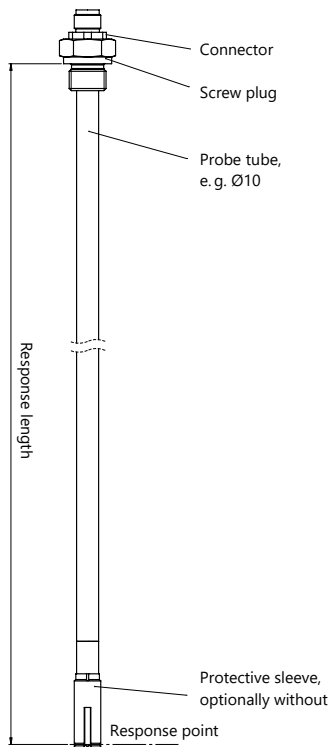

Figure 3: LS 300 E Steck

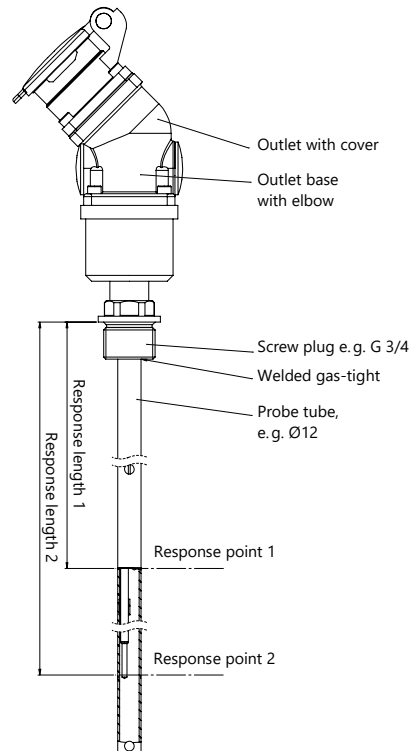

Figure 4: LS 300 E Steck/01

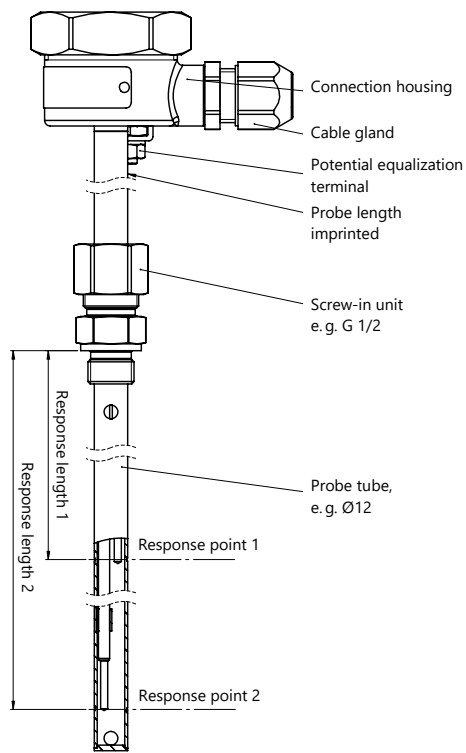

Figure 5: LS 300 E DUO/03

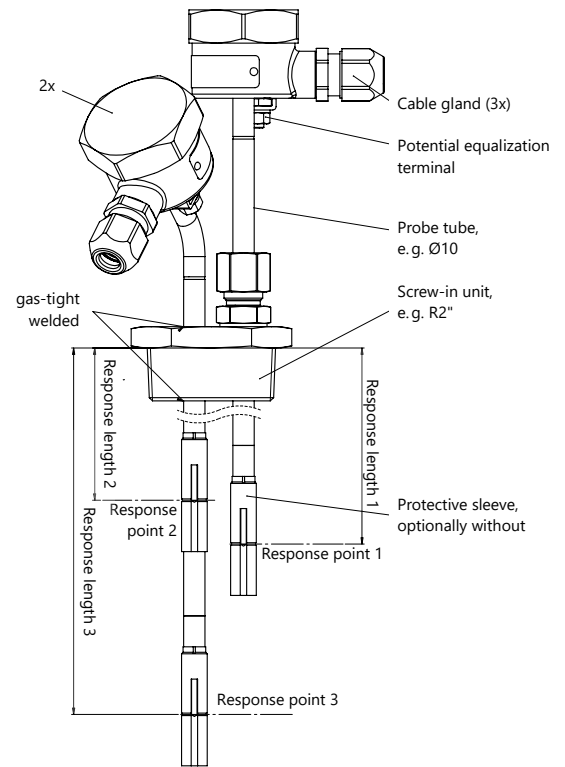

Figure 6: LS 300 E TRIO/02

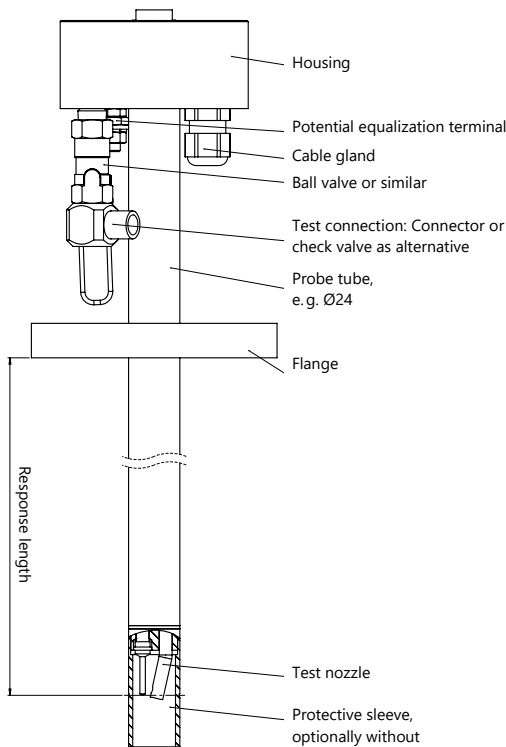

Figure 7: LS 300 FSP

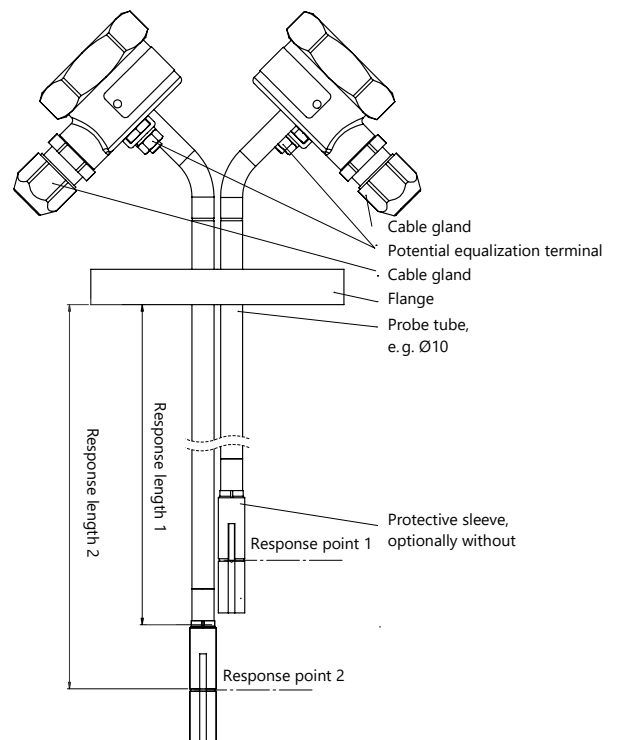

Figure 8: LS 300 F Duo

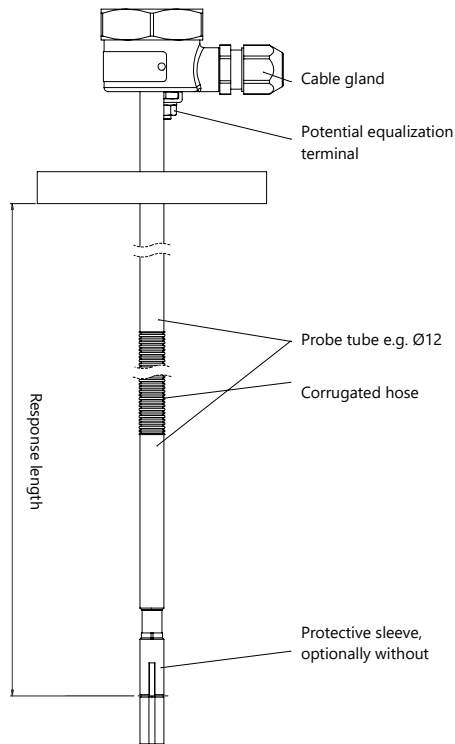

Figure 9: LS 300 FX

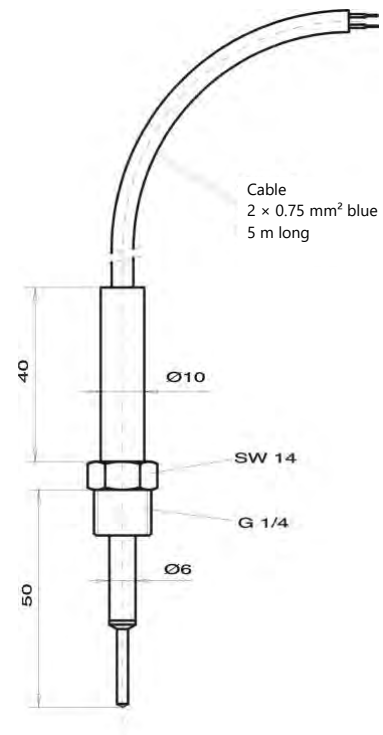

Figure 10: LS 300 EB6

Level detector circuit

Only for connection to the measuring transducer type LS 500 ...

Temperatures

	Media temperature T_F	Ambient temperature T_a
Standard	-25 °C ... +50 °C	-25 °C ... +80 °C
High (H-Typ)	-25 °C ... +80 °C	
Highest (HH-Typ)	-10 °C ... +110 °C	
Low (L-Typ)	-40 °C ... +50 °C	-40 °C ... +80 °C

Pressures

Standard 0 bar ... 3 bar
 Special version 0 bar ... 25 bar

Heating times

at $T_a = -20$ °C < two minutes
 at $T_a = +60$ °C < 15 seconds

Housing protection (according to EN 60529)

LS 300 ... \geq IP67

Measuring transducer LS 500 ...:

Dimensions

There are two different housing designs:

Wall mounting housing

This design has the dimensions (H×W×D) 150 mm × 75 mm × 110 mm.



Figure 1.4k: Measuring transducer LS 500 S in wall mounting housing

Mounting rail housing

This design has the dimensions (H×W×D) 114,5 mm × 22,5 mm × 99 mm.



Figure 1.4l: Measuring transducer LS 500 H ... in mounting rail housing

Power supply

Type LS 500 ...

U = 24 V_{AC} / 115 V_{AC} / 230 V_{AC} ± 10 %, 40 Hz ... 60 Hz, < 4 VA, or

U = 24 V_{DC} ± 20 %, < 5 W

Type LS 500 H ...

U = 23 V_{DC} ... 30 V_{DC}, < 8 W

Level detector circuit

Only for connection to the level detector type LS 300 ...

Output circuit

AC U ≤ 250 V; I ≤ 5 A; P ≤ 100 VA; cos φ ≥ 0.7

DC U ≤ 250 V; I ≤ 5 A; P ≤ 100 W

When using the measuring transducer type LS 500 H SIL with a level detector in the hazardous area, the maximum voltage for the contacts of the sensor relay is reduced to 42 V_{AC} or 60 V_{DC}.

Temperatures

Ambient temperature -25 °C ... +50 °C

Housing protection (according to EN 60529)

Plug-on housing IP40

Mounting rail housing IP30

2 Material of level detector

All components coming into contact with media are made of stainless steel no. 1.4571 (316Ti), Hastelloy C4 (2.4610), Hastelloy B (2.4617) or Hastelloy C22 (2.4602). Flanges can be made of steel with plated sealing surfaces of stainless steel no. 1.4571 (316Ti), Hastelloy C4 (2.4610), Hastelloy B (2.4617) or Hastelloy C22 (2.4602).

Special materials:

Material	Wetted parts made of
From 1.4301 (304) up to 1.4571 (316Ti) without 1.4305 (303)	Stainless steel
B-2 (2.4617), C-4 (2.4610), or C-22 (2.4602)	Hastelloy
Tantalum (sensor tip) and stainless steel with E-CTFE coating	Tantalum and Halar
Tantalum (sensor tip) and stainless steel	Tantalum and stainless steel
Tantalum	Tantalum

Table 2: Special materials for components of level detector LS 300 ... coming into contact with media

3 Area of application

The level detector type LS 300 ... and measuring transducer type LS 500 ... as level limit switch of overflow protection device for containers to store water-polluting liquids.

Level detector type LS 300 ... is operated according to the following conditions in containers for storing flammable and non-flammable water-polluting liquids, from which no permanent adhesions are expected.

- a) Atmospheric conditions
 - Temperature: -20 °C ... +60 °C
 - Pressure: 800 mbar ... 1,1 bar
- b) Different conditions
 - Liquid temperature
 - Normal temperature: -25 °C ... +50 °C
 - High temperature „H“: -25 °C ... +80 °C
 - Highest temperature „HH“: -10 °C ... +110 °C
 - OPressure
 - Standard pressure range: 0 bar ... 3 bar
 - Special version: 0 bar ... 25 bar

Deviations such as 0 °C ... +85 °C are indicated on the type plate.

If the sensor tip is cooled down due to strong sprays or strong gas flow, a premature shutdown occurs. One remedy against strong gas flow is to retrofit a protective probe sleeve.

4 Fault and error messages

Level detector LS 300:

Corrosion monitoring is not required since the level detector is constantly being tested and monitored by the measuring transducer. The integrated scanner in the measuring transducer checks the PTC resistor in the level detector several times during a second, at the start and during the entire filling period. This process is indicated on the measuring transducer by blinking of the blue LED. Queried is the typical characteristic of the PTC resistor during heating up and cooling down. A dysfunction of the PTC resistor due to corrosion of the probe sleeve is detected and signalled as an alarm signal of the overfill protection device. Faults such as short circuit and cable breakage due to corrosion are immediately detected and signalled.

Measuring transducer LS 500:

During power failure, failure of the device fuse, non-functioning sensor elements, interruption or short circuit of the signal line from the level detector to the measuring transducer, the sensor relay in the measuring transducer releases and switches the sequential circuit (opening relay is the same as: "Response level" of overfill protection device has been reached).

LS 500 ... S: In addition to the relay control described, the error relay activates during an interruption or short circuit of the signal line from the level detector to the measuring transducer. At the same time the red "Error" LED lights up. In case of a short circuit additionally the blue "Scanner" LED lights up.

LS 500 H SIL: In addition to the previously described relay control, the "Error" LED lights up during an interruption or short circuit of the signal line from the level detector to the measuring transducer. If an error is detected by the test electronics (SIL fault), the SIL error relay is activated, the "SIL Error" LED lights up and the "Error" LED starts to flash. The measuring transducer can only be reset from the "SIL error" state to normal operation by interrupting the power supply.

5 Installation notes

Level detector LS 300:

The level detector must be installed in the container in a position where no liquid splashes or strong vapour flows would cause the overfill protection device to respond prematurely or cause faults. The level detectors should be installed as vertically as possible so that residual liquid can drip easily from the probe.

During all work on the container, the relevant safety and accident prevention regulations of the employers' liability insurance associations, as well as the rules and regulations of the Professional Associations for engineering and electrical technology, must be observed.

Level detectors LS 300 ...U... resp. overvoltage protection:

For use in potentially explosive atmospheres, where a part of an intrinsically safe electric circuit in Zone 0 is installed in such a way that there is a risk of dangerous or damaging differences in potential within Zone 0, an overvoltage protection device must be installed. The overvoltage protection is required between every conductor of the cable, including the shield and the system, unless this conductor is already connected to the system. The overvoltage protection device must be installed outside, but as close to the border of Zone 0 as technically possible, preferably at up to 1 m.

The level detector LS 300 ...U... is fitted with internal overvoltage protection. The sensor head must therefore be set up outside Zone 0. External overvoltage protection, e.g. BA 350-..., must be set up outside Zone 0. For the electrical connection (wire cross-section 4 mm²) from the housing to the container, an external potential equalization terminal is provided.

Measuring transducer LS 500 ...:

If measuring transducer LS 500 ... is mounted outdoors, the housing protection class must be at least IP54.

The wiring must be carried out only with the power disconnected. Special local rules and regulations of relevant Professional Associations and Authorities must be observed (e. g. VDE in Germany). The maximum admissible cable length is 250 m for 0.5 mm², 500 m for 1 mm² and 750 m for 1.5 mm². Other cross-sections result in other maximum cable lengths. When using the overfill protection device in potentially explosive areas, the wiring from the level detector to the measuring transducer must be marked as intrinsically safe cable. For colour marking, a blue cable or blue marked cable is to be used. The measuring transducer must be installed outside the potentially explosive atmospheres/areas.

Measuring transducer type LS 500 ... in wall mounting housing

The measuring transducer is suitable for wall mounting.

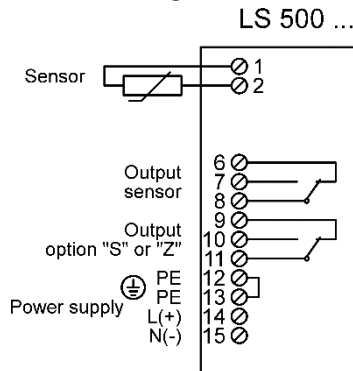

Figure 5a: Measuring transducer in wall mounting housing

Measuring transducer type LS 500 H ... in mounting rail housing

The measuring transducer is intended for installation on a mounting rail.

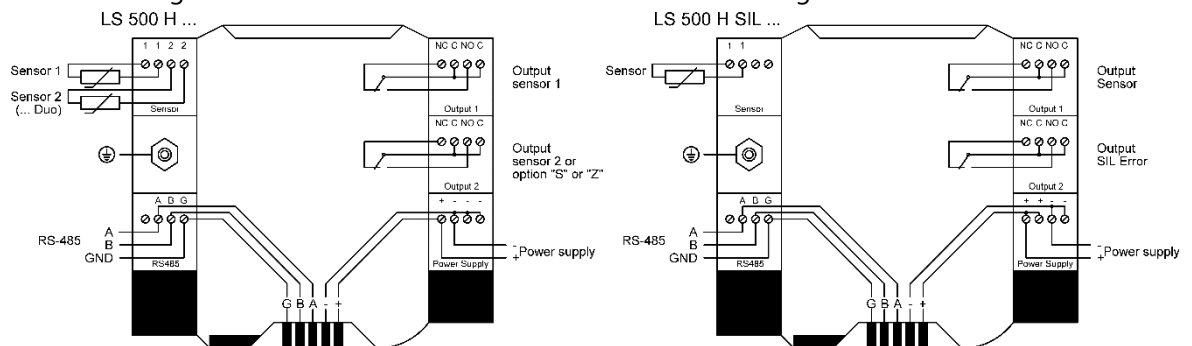

Figure 5b: Measuring transducer in mounting rail housing

6 Setting instructions

Based on the permissible filling ratio in the container, the response level (A) of the overfill protection device must be determined in accordance with Appendix 1 of the approval guidelines for overfill protection devices. The switch delay time of ≤ 2 s must be taken into consideration here.

The level detectors type LS 300 E... comprise a sensor tube with screw-in unit which projects height adjustable into the storage container. The respective sensor length is permanently impressed above the groove marking at the upper end of the sensor. The sensor length is a measure of the distance between the groove marking and the response point of the level detector. The response length (L) is calculated from the container dimensions and the response level and is set on the level detector as distance between the hexagon nut seat of the screw-in unit and the groove marking on the protective sleeve of the probe at the bottom end of the level detector. When installed, the correct adjustment of the response level can be checked with the control dimension (Y). Y is the distance between the groove marking on the upper end of the sensor tube and the hexagon nut seat of the screw-in unit. After subtracting the control dimension from the imprinted sensor length you get the result of the response length.

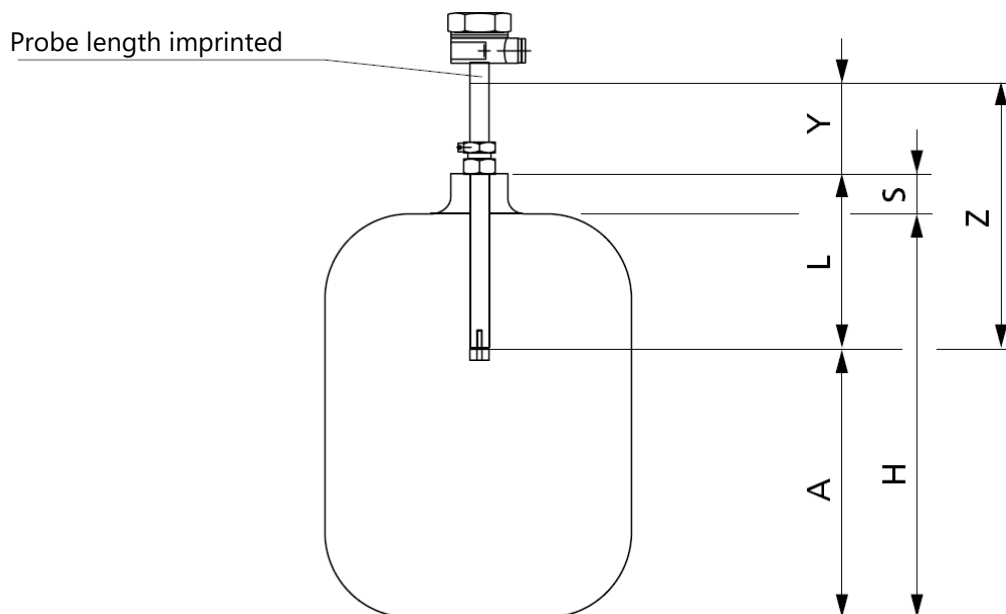

Figure 6: Setting instructions

A =	Response level	S =	Spigot or muff height
L =	Response length	Y =	Control dimension
H =	Container height	Z =	Sensor length

The response length (L) is calculated with

$$L = (H - A) + S$$

For a check, the response length (L) can be calculated without removing the level detector

$$L = Z - Y$$

To fix the sensor tube, it is necessary to tighten the upper gland screw and the locking screw of the screw-in unit. The screw-in thread must then be provided with a suitable resistant sealing material and screwed into the existing tank coupling.

Since the response length (L) of level detectors type LS 300 F... with flange is not variable (sensor tube welded with flange), this dimension must be determined precisely from the container dimensions prior to ordering and be specified. The response length is permanently impressed in the flange of the level detector.

7 Instructions

The level limit switch is generally maintenance-free when operated as intended.

Before commissioning, all system parts of the overflow protection device must be checked for correct connection and function. The electrical supply, as well as downstream devices, must be checked.

The general instructions for the devices being used must be observed.

8 Recurring inspections

The functionality of the overflow protection device must be tested at reasonable intervals, but at least once a year. The operator shall be responsible for the type and frequency of inspection within the specified period.

The test must be conducted in such a way that proof is obtained of correct operation of the overflow protection device with all components interacting. This condition can be satisfied by allowing the liquid to reach the response level during a filling process. If filling to the response level is not practicable, the level detector should be caused to respond through simulation of the fill level or physical measuring effect by suitable means. If the functionality of the level detector / measuring transducer is demonstrable by other means (exclusion of function-impairing faults), the test can also be carried out by simulating the corresponding output signal.

Function test for level detectors without test connection:

- a) Remove the level detector and immerse it in the stored liquid.

Shortly after the immersion (≤ 2 s) the relay in the measuring transducer must de-energize and thereby activate the signalling device.

- b) By filling the container up to response level A.

The filling process must be very closely monitored! The overflow protection and the downstream signalling devices must respond.

The test to determine whether the alarm system of the overflow protection device works in accordance with the closed-circuit principle or whether the monitoring of the sensor element functions, can be performed as follows:

- a) Interrupt the auxiliary power supply of the measuring transducer.

The green LED of the measuring transducer must turn off and the downstream signalling devices must respond.

- b) Interrupt or short-circuit the signal line between the level detector and measuring transducer.

The level limit switch and the downstream signalling devices must respond.

Function test for level detectors with test connection type LS 300 ...P...:

To enable the test of level detectors type LS 300 ...P..., an external compressed gas system must be connected to the test connection integrated in the level detector. This is carried out via a plug connector or screwed connection (version with check valve LS 300 ...PR...). As additional protection to the container there is a ball valve on the test connection of the level detector behind the coupling or the check valve. The ball valve must be opened for the test process.

The gas is fed to the PTC resistor via the test connection. This cools the PTC resistor down to the value which corresponds to the immersion in liquid.

The functionality of the overflow prevention device is displayed by the activated signalling device.

Function test for measuring transducers with test button:

To control the function of the entire overflow protection device the measuring transducer can be fitted with a test button "Test". Whenever this button is pressed, the heat output of the PTC resistor is reduced so much that it cools down (equivalent of a submerged sensor) and the alarm system is triggered. The alarm must occur no more than two seconds after the button has been pressed (keep the button pressed). After releasing the test button the PTC resistor is heated up and after the heating-up time (> 5 s) the overflow protection device is back again in alarm state. If no alarm is triggered after the test button has been pressed or immediately after its release, the overflow protection device must be checked immediately.

The selected test method and the result must be documented.

Level detector with measuring transducer LS 500 H SIL:

In the version of the level limit switch with measuring transducer LS 500 H SIL the function-impairing faults are excluded by a permanent self-monitoring function. For this reason, the recurring inspection is not required.

By pressing the test button "Test" for less than two seconds, the downstream signalling devices can be tested. If the test button is pressed for longer than five seconds, a "SIL Error" is triggered and the downstream fault message devices can be checked. The measuring transducer can only be reset from the "SIL error" state to normal operation by interrupting the power supply.

**Allgemeine
bauaufsichtliche
Zulassung/
Allgemeine
Bauartgenehmigung**

Zulassungsstelle für Bauprodukte und Bauarten

Bautechnisches Prüfamt

Eine vom Bund und den Ländern
gemeinsam getragene Anstalt des öffentlichen Rechts

Mitglied der EOTA, der UEAtc und der WFTAO

Datum:

05.11.2019

Geschäftszeichen:

II 23-1.65.11-47/19

Nummer:

Z-65.11-228

Geltungsdauer

vom: **9. Dezember 2019**

bis: **9. Dezember 2024**

Antragsteller:

FAFNIR GmbH

Schnackenburgallee 149c

22525 Hamburg

Gegenstand dieses Bescheides:

**Standaufnehmer (Kaltleiterelemente) vom Typ LS 300 ... und Messumformer LS 500 ... als
Standgrenzschalter von Überfüllsicherungen**

Der oben genannte Regelungsgegenstand wird hiermit allgemein bauaufsichtlich
zugelassen/ genehmigt.

Dieser Bescheid umfasst sechs Seiten und eine Anlage.

Der Gegenstand ist erstmals am 26. Juli 1999 allgemein bauaufsichtlich zugelassen worden.

DIBt

I ALLGEMEINE BESTIMMUNGEN

- 1 Mit diesem Bescheid ist die Verwendbarkeit bzw. Anwendbarkeit des Regelungsgegenstandes im Sinne der Landesbauordnungen nachgewiesen.
- 2 Dieser Bescheid ersetzt nicht die für die Durchführung von Bauvorhaben gesetzlich vorgeschriebenen Genehmigungen, Zustimmungen und Bescheinigungen.
- 3 Dieser Bescheid wird unbeschadet der Rechte Dritter, insbesondere privater Schutzrechte, erteilt.
- 4 Dem Verwender bzw. Anwender des Regelungsgegenstandes sind, unbeschadet weitergehender Regelungen in den "Besonderen Bestimmungen", Kopien dieses Bescheides zur Verfügung zu stellen. Zudem ist der Verwender bzw. Anwender des Regelungsgegenstandes darauf hinzuweisen, dass dieser Bescheid an der Verwendungs- bzw. Anwendungsstelle vorliegen muss. Auf Anforderung sind den beteiligten Behörden ebenfalls Kopien zur Verfügung zu stellen.
- 5 Dieser Bescheid darf nur vollständig vervielfältigt werden. Eine auszugsweise Veröffentlichung bedarf der Zustimmung des Deutschen Instituts für Bautechnik. Texte und Zeichnungen von Werbeschriften dürfen diesem Bescheid nicht widersprechen, Übersetzungen müssen den Hinweis "Vom Deutschen Institut für Bautechnik nicht geprüfte Übersetzung der deutschen Originalfassung" enthalten.
- 6 Dieser Bescheid wird widerruflich erteilt. Die Bestimmungen können nachträglich ergänzt und geändert werden, insbesondere, wenn neue technische Erkenntnisse dies erfordern.
- 7 Dieser Bescheid bezieht sich auf die von dem Antragsteller gemachten Angaben und vorgelegten Dokumente. Eine Änderung dieser Grundlagen wird von diesem Bescheid nicht erfasst und ist dem Deutschen Institut für Bautechnik unverzüglich offenzulegen.
- 8 Die von diesem Bescheid umfasste allgemeine Bauartgenehmigung gilt zugleich als allgemeine bauaufsichtliche Zulassung für die Bauart.

II BESONDERE BESTIMMUNGEN

1 Regelungsgegenstand und Verwendungs- bzw. Anwendungsbereich

(1) Gegenstand dieses Bescheides sind Standgrenzscharter (siehe Anlage 1), die als Teil einer Überfüllsicherung dazu dienen, bei der Lagerung wassergefährdender Flüssigkeiten Überfüllungen von Behältern zu verhindern. Die Standaufnehmer bestehen aus gekapselten Kaltleitern die elektrisch aufgeheizt werden, beim Eintauchen in die Lagerflüssigkeit abkühlen und dadurch den elektrischen Widerstand verändern. Diese Widerstandsänderung löst im Messumformer ein binäres, elektrisches Signal aus, mit dem rechtzeitig vor Erreichen des zulässigen Füllungsgrades der Füllvorgang unterbrochen oder akustisch und optisch Alarm ausgelöst wird. Die für die Melde- oder Steuerungseinrichtung erforderlichen Teile und der Signalverstärker sind nicht Gegenstand dieses Bescheides.

(2) Die Standaufnehmer werden aus Edelstahl (Werkstoff-Nr. 1.4301 bis 1.4571 mit Ausnahme von 1.4305) bzw. Hastelloy (Werkstoff-Nr. 2.4601, 2.4610, 2.4617) gefertigt. Sie können auch mit Sondenspitzen aus Tantal oder mit E-CTFE (Halar)-Beschichtung gefertigt werden.

(3) Die Standaufnehmer dürfen für Behälter unter Drücken bis 3 bar (in Sonderausführung bis 25 bar) und je nach Ausführung bei Temperaturen der Lagerflüssigkeit von -40 °C bis +110 °C verwendet werden. Die Umgebungstemperatur am Messumformer muss zwischen -25 °C und +50 °C liegen.

(4) Mit diesem Bescheid wird der Nachweis der Funktionssicherheit des Regelungsgegenstandes im Sinne von Absatz (1) erbracht.

(5) Der Bescheid wird unbeschadet der Bestimmungen und der Prüf- oder Genehmigungsvorbehalte anderer Rechtsbereiche erteilt.

(6) Dieser Bescheid berücksichtigt die wasserrechtlichen Anforderungen an den Regelungsgegenstand. Gemäß § 63 Abs. 4 Nr. 2 und 3 WHG¹ gilt der Regelungsgegenstand damit wasserrechtlich als geeignet.

(7) Die Geltungsdauer dieses Bescheides (siehe Seite 1) bezieht sich auf die Verwendung im Sinne von Einbau des Regelungsgegenstandes und nicht auf die Verwendung im Sinne der späteren Nutzung.

2 Bestimmungen für das Bauprodukt

2.1 Allgemeines

Der Standgrenzscharter und seine Teile müssen den Besonderen Bestimmungen und der Anlage dieses Bescheides sowie den beim Deutschen Institut für Bautechnik hinterlegten Angaben entsprechen.

2.2 Eigenschaften und Zusammensetzung

(1) Der Regelungsgegenstand setzt sich aus folgenden Einzelteilen zusammen (Nummierung siehe Anlage 1):

(1) Standaufnehmer für folgende Temperaturen der Lagerflüssigkeit:

Typ LS 300 ... Normaltyp, für -25 °C bis +50 °C (Umgebungstemperatur/
Gasraum des Behälters bis +80 °C)

Typ LS 300 ... L für -40 °C bis +50 °C (Umgebungstemperatur/
Gasraum des Behälters bis +80 °C)

Typ LS 300 ... H für -25 °C bis +80 °C

Typ LS 300 ... HH für -10 °C bis +110 °C

¹ Wasserhaushaltsgesetz vom 31. Juli 2009 (BGBl. I S. 2585), das zuletzt durch Artikel 1 des Gesetzes vom 18. Juli 2017 (BGBl. I S. 2771) geändert worden ist

- (2) Messumformer für folgende Umgebungstemperaturen:

Typ LS 500 . . . für -25 °C bis +50 °C

Die vollständige Typenbezeichnung entspricht dem Typenschlüssel gemäß der Technischen Beschreibung².

(2) Die Teile der Überfüllsicherung, die nicht Gegenstand der von dem Bescheid erfassten allgemeinen bauaufsichtlichen Zulassung sind, dürfen nur verwendet werden, wenn sie den Anforderungen des Abschnitts 3 "Allgemeine Baugrundsätze" und des Abschnitts 4 "Besondere Baugrundsätze" der ZG-ÜS³ entsprechen. Sie brauchen jedoch keine Zulassungsnummer zu haben.

2.3 Herstellung und Kennzeichnung

2.3.1 Herstellung

Der Standgrenzschalter darf nur im Werk des Antragstellers, FAFNIR GmbH in 22525 Hamburg, hergestellt werden. Er muss hinsichtlich Bauart, Abmessungen und Werkstoffen den in der im DIBt hinterlegten Liste aufgeführten Unterlagen entsprechen.

2.3.2 Kennzeichnung

Der Standgrenzschalter, dessen Verpackung oder dessen Lieferschein muss vom Hersteller mit dem Übereinstimmungszeichen (Ü-Zeichen) nach den Übereinstimmungszeichen-Verordnungen der Länder gekennzeichnet werden. Die Kennzeichnung darf nur erfolgen, wenn die Voraussetzungen nach Abschnitt 2.4 erfüllt sind.

Zusätzlich sind die zulassungspflichtigen Teile selbst mit folgenden Angaben zu kennzeichnen:

- Hersteller oder Herstellerzeichen^{*)},
- Typenbezeichnung,
- Serien- oder Chargennummer bzw. Identnummer bzw. Herstellungsdatum,
- Zulassungsnummer^{*)}.

^{*)} Bestandteil des Ü-Zeichens, das Teil ist nur wiederholt mit diesen Angaben zu kennzeichnen, wenn das Ü-Zeichen nicht direkt auf dem Teil aufgebracht wird.

2.4 Übereinstimmungsbestätigung

2.4.1 Allgemeines

Die Bestätigung der Übereinstimmung des Standgrenzschalters mit den Bestimmungen der von dem Bescheid erfassten allgemeinen bauaufsichtlichen Zulassung muss für das Herstellwerk mit einer Übereinstimmungserklärung des Herstellers auf der Grundlage einer werkseigenen Produktionskontrolle und einer Erstprüfung des Standgrenzschalters durch eine hierfür anerkannte Prüfstelle erfolgen. Die Übereinstimmungserklärung hat der Hersteller durch Kennzeichnung der Bauprodukte mit dem Übereinstimmungszeichen (Ü-Zeichen) unter Hinweis auf den Verwendungszweck abzugeben.

² Technische Beschreibung des Antragstellers vom Stand 08.2019 auf Grundlage der von der TÜV NORD CERT GmbH geprüften Technischen Beschreibung vom Stand 08.2017 für Standaufnehmer Typ LS 300 ... und Messumformer Typ LS 500 ...

³ ZG-ÜS:2012-07 Zulassungsgrundsätze für Überfüllsicherungen des Deutschen Instituts für Bautechnik

2.4.2 Werkseigene Produktionskontrolle

(1) Im Herstellwerk ist eine werkseigene Produktionskontrolle einzurichten und durchzuführen. Unter werkseigener Produktionskontrolle wird die vom Hersteller vorzunehmende kontinuierliche Überwachung der Produktion verstanden, mit der dieser sicherstellt, dass die von ihm hergestellten Bauprodukte den Bestimmungen der von dem Bescheid erfassten allgemeinen bauaufsichtlichen Zulassung entsprechen. Im Rahmen der werkseigenen Produktionskontrolle ist eine Stückprüfung jedes Standgrenzschalters oder seiner Einzelteile durchzuführen. Durch die Stückprüfung hat der Hersteller zu gewährleisten, dass die Werkstoffe und Maße sowie das fertiggestellte Bauprodukt dem geprüften Baumuster entsprechen und der Standgrenzschalter funktionssicher ist.

(2) Die Ergebnisse der werkseigenen Produktionskontrolle sind aufzuzeichnen und auszuwerten. Die Aufzeichnungen müssen mindestens folgende Angaben enthalten:

- Bezeichnung des Standgrenzschalters,
- Art der Kontrolle oder Prüfung,
- Datum der Herstellung und der Prüfung,
- Ergebnisse der Kontrollen oder Prüfungen,
- Unterschrift des für die werkseigene Produktionskontrolle Verantwortlichen.

(3) Die Aufzeichnungen sind mindestens fünf Jahre aufzubewahren. Sie sind dem Deutschen Institut für Bautechnik und der zuständigen obersten Bauaufsichtsbehörde auf Verlangen vorzulegen.

(4) Bei ungenügendem Prüfergebnis sind vom Hersteller unverzüglich die erforderlichen Maßnahmen zur Abstellung des Mangels zu treffen. Standaufnehmer und Messumformer, die den Anforderungen nicht entsprechen, sind so zu handhaben, dass eine Verwechslung mit übereinstimmenden ausgeschlossen ist. Nach Abstellung des Mangels ist - soweit technisch möglich und zum Nachweis der Mängelbeseitigung erforderlich - die betreffende Prüfung unverzüglich zu wiederholen.

2.4.3 Erstprüfung durch eine anerkannte Prüfstelle

Im Rahmen der Erstprüfung sind die in den ZG-ÜS aufgeführten Funktionsprüfungen durchzuführen. Wenn die diesem Bescheid zugrunde liegenden Nachweise an Proben aus der laufenden Produktion erbracht wurden, ersetzen diese Prüfungen die Erstprüfung.

3 Bestimmungen für Planung und Ausführung

3.1 Planung

Vom Hersteller oder vom Betreiber des Standgrenzschalters ist der Nachweis der hinreichenden chemischen Beständigkeit der unter Abschnitt 1 (2) genannten Werkstoffe gegenüber den wassergefährdenden Flüssigkeiten und deren Dämpfen oder Kondensat zu führen. Zur Nachweisführung können Angaben der Werkstoffhersteller, Veröffentlichungen in der Fachliteratur, eigene Erfahrungswerte oder entsprechende Prüfergebnisse herangezogen werden.

3.2 Ausführung

(1) Die Überfüllsicherung mit einem Standgrenzschalter nach diesem Bescheid muss entsprechend Abschnitt 1.1 der Technischen Beschreibung angeordnet bzw. entsprechend deren Abschnitten 5 und 6 eingebaut und eingestellt werden. Mit dem Einbauen, Instandhalten, Instandsetzen und Reinigen des Standgrenzschalters dürfen nur solche Betriebe beauftragt werden, die über Kenntnisse des Brand- und Explosionsschutzes verfügen, wenn diese Tätigkeiten an Behältern für Flüssigkeiten mit Flammpunkt ≤ 55 °C durchgeführt werden. Nach Abschluss der Montage der Überfüllsicherung muss durch einen Sachkundigen des einbauenden Betriebes eine Prüfung auf ordnungsgemäßen Einbau und einwandfreie Funktion durchgeführt werden. Über die Einstellung der Überfüllsicherung und die ordnungsgemäße Funktion ist eine Bescheinigung auszustellen und dem Betreiber zu übergeben.

(2) Wird ein Messumformer (2) nach Abschnitt 2.2(1) nicht in einem trockenen Raum betrieben, muss er in einem Schutzgehäuse angeordnet werden, das mindestens der Schutzart IP54 nach DIN EN 60529⁴ entspricht.

4 Bestimmungen für Nutzung, Unterhalt, Wartung und wiederkehrende Prüfungen

(1) Die Überfüllsicherung mit einem Standgrenzschalter nach diesem Bescheid muss nach den ZG-ÜS Anhang 1 "Einstellhinweise für Überfüllsicherungen von Behältern" und den ZG-ÜS Anhang 2 "Einbau- und Betriebsrichtlinie für Überfüllsicherungen" betrieben werden. Die Anhänge und die Technische Beschreibung sind vom Hersteller mitzuliefern. Die Anhänge 1 und 2 der ZG-ÜS dürfen zu diesem Zweck kopiert werden.

(2) Die Funktionsfähigkeit der Überfüllsicherung mit einem Standgrenzschalter nach diesem Bescheid muss in angemessenen Zeitabständen, mindestens aber einmal im Jahr, nach Abschnitt 8 der Technischen Beschreibung und entsprechend den Anforderungen des Abschnitts 5.2 von Anhang 2 der ZG-ÜS geprüft werden. Es liegt in der Verantwortung des Betreibers, die Art der Überprüfung und die Zeitabstände im genannten Zeitrahmen zu wählen.

(3) Aufgrund der nachgewiesenen besonderen Zuverlässigkeit (Fehlersicherheit SIL 2 gemäß DIN EN 61508⁵) für den Messumformer (2) Typ LS 500 H SIL mit dem Standaufnehmer (1) Typ LS 300... entsprechend Abschnitt 2.2(1) darf von der jährlichen Betriebsprüfung (wiederkehrende Prüfung) dieser Teile abgewichen werden. Die Prüfungen sind vom Betreiber entsprechend der SIL-Stufe 2 in Abstimmung mit dem Hersteller festzulegen. Die erforderliche Prüfung der nachgeschalteten Anlagenteile kann bei dieser Überfüllsicherung durch Betätigung der Prüftaste "Test" weniger als 5 Sekunden für die Alarmeinrichtungen und länger als 5 Sekunden für die Störmeldeeinrichtungen eingeleitet werden. Die nachgeschalteten Anlagenteile müssen dabei so angeschlossen sein, dass bei Leitungsbruch oder bei Ausfall der Hilfsenergie diese Störungen gemeldet werden.

(4) Stör- und Fehlermeldungen sind in Abschnitt 4 der Technischen Beschreibung beschrieben.

(5) Bei Wiederinbetriebnahme des Behälters nach Stilllegung oder bei Wechsel der wassergefährdenden Flüssigkeit, bei dem mit einer Änderung der Einstellungen oder der Funktion der Überfüllsicherung zu rechnen ist, ist eine erneute Funktionsprüfung, siehe Abschnitt 3.2 (1), durchzuführen.

Holger Eggert
Referatsleiter



⁴ DIN EN 60529:2014-09

⁵ DIN EN 61508 Teil 1-7:2011-02 Funktionale Sicherheit sicherheitsbezogener elektrischer/elektronischer/programmierbarer elektronischer Systeme

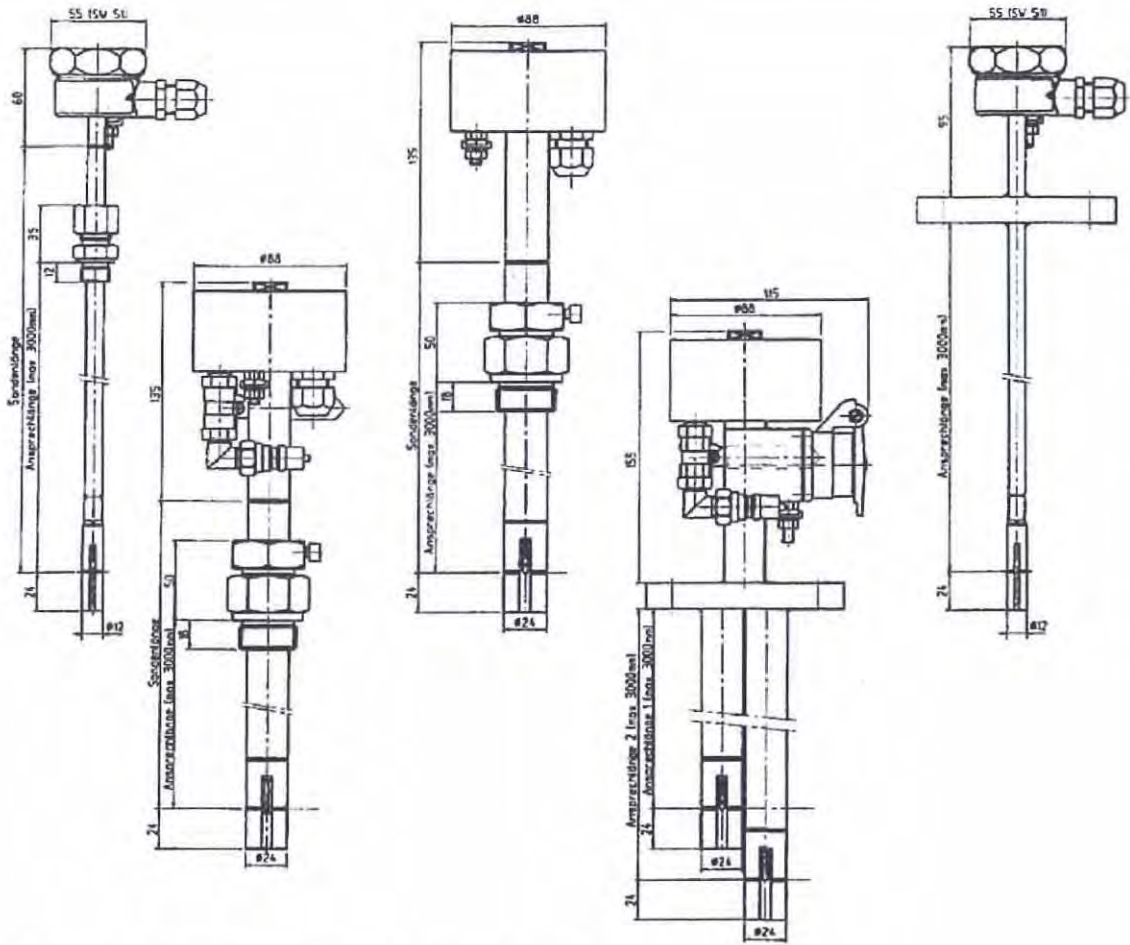

Schematische Darstellung der Überfüllsicherung

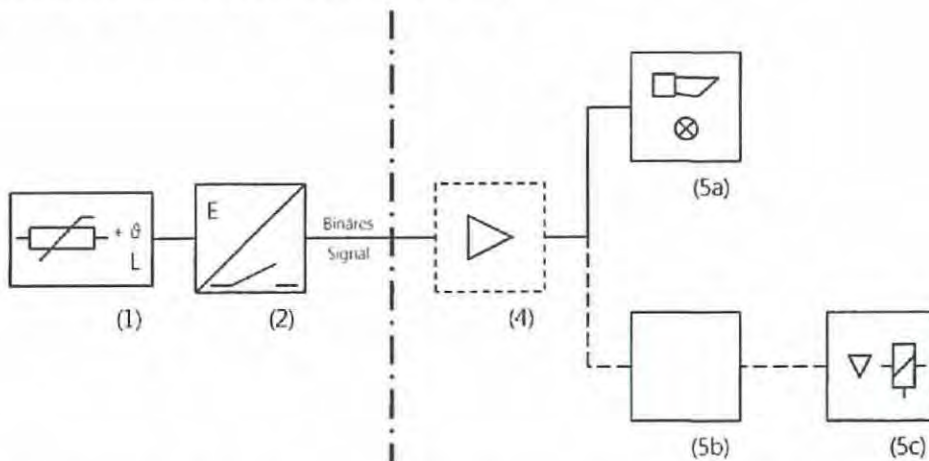

- 1 Standaufnehmer Typ LS 300 ...
- 2 Messumformer Typ LS 500 ...
- 4 Signalverstärker

- 5a Meldeeinrichtung
- 5b Steuerungseinrichtung
- 5c Stellglied

(4) bis (5c) nicht Gegenstand
dieser allgemeinen
bauaufsichtlichen Zulassung

Standaufnehmer (Kaltleiterelemente) vom Typ LS 300 ... und Messumformer LS 500 ... als
Standgrenzschalter von Überfüllsicherungen

Übersicht

Anlage 1

Translation

(1) **EU-Type Examination Certificate**

(2) Equipment and protective systems intended for use in potentially explosive atmospheres, **Directive 2014/34/EU**



(3) **Certificate Number** TÜV 00 ATEX 1656 X **issue:** 00

(4) for the product: Overfill Prevention Sensor type 81 D-Ex ... and type 83 UV-...
Level Detector type LS 300 ...
High-Level Sensor type SEPARIX-T ...

(5) of the manufacturer: **FAFNIR GmbH**

(6) Address: Schnackenburgallee 149 c, 22525 Hamburg, Germany

Order number: 8000488168

Date of issue: 2018-09-11

(7) The design of this product and any acceptable variation thereto are specified in the schedule to this EU-Type Examination Certificate and the documents therein referred to.

(8) The TÜV NORD CERT GmbH, Notified Body No. 0044, in accordance with Article 17 of the Directive 2014/34/EU of the European Parliament and the Council of 26 February 2014, certifies that this product has been found to comply with the Essential Health and Safety Requirements relating to the design and construction of products intended for use in potentially explosive atmospheres given in Annex II to the Directive.

The examination and test results are recorded in the confidential ATEX Assessment Report No. 18 203 228654.

(9) Compliance with the Essential Health and Safety Requirements has been assured by compliance with:

EN 60079-0:2012 + A11:2013

EN 60079-11:2012

EN 60079-26:2015

except in respect of those requirements listed at item 18 of the schedule.

(10) If the sign "X" is placed after the certificate number, it indicates that the product is subject to the Specific Conditions for Use specified in the schedule to this certificate.

11) This EU-Type Examination Certificate relates only to the design, and construction of the specified product. Further requirements of the Directive apply to the manufacturing process and supply of this equipment. These are not covered by this certificate.

(12) The marking of the product shall include the following:



See item 15 of the schedule

TÜV NORD CERT GmbH, Langemarckstraße 20, 45141 Essen, notified by the central office of the countries for safety engineering (ZLS), Ident. Nr. 0044, legal successor of the TÜV NORD CERT GmbH & Co. KG Ident. Nr. 0032

The head of the notified body

Roder

Hanover office, Am TÜV 1, 30519 Hannover, Tel. +49 511 998-61455, Fax +49 511 998-61590

This certificate may only be reproduced without any change, schedule included.
Excerpts or changes shall be allowed by the TÜV NORD CERT GmbH

(13) SCHEDULE

(14) EU-Type Examination Certificate No. TÜV 00 ATEX 1656 X issue 00

(15) Description of product

The sensors are intrinsically safe equipment that can be used in a potentially explosive area and are used to detect a limit level. The overflow prevention sensors (OPS) serve as part of an overflow prevention. The level detector is used as part of an overflow protection, dry run protection or filling control. The high-level sensor is used to detect backwater within a light liquid separator.

In the future, the sensors may also be manufactured in accordance with the test documents listed in the ATEX test report. The changes affect the addition of new types. Furthermore, the equipment was assessed according to the latest standards.

The marking is as follows:

Type 81 D-Ex resp. 83 UV-... resp. LS 300 ... resp. SEPARIX-T ...

 II 1 G Ex ia IIC T4 Ga resp.
 II 1/2 G Ex ia IIC T4 Ga/Gb

Type 81 D-Ex U resp. LS 300 ... U...

 II 1/2 G Ex ia IIC T4 Ga/Gb

Type LS 300 ... C

 II 1 G Ex ia IIB T4 Ga resp.
 II 1/2 G Ex ia IIB T4 Ga/Gb

Type designation:

Type 81 D-Ex ...:

81 D-Ex OPS made of stainless steel
 81 D-Ex U OPS additionally with overvoltage protection

Type 83 UV-...:

83 UV-A Stainless steel OPS with junction box and wall fitting
 83 UV-C Stainless steel OPS with permanently connected cable and wall fitting
 83 UV-SCR Brass OPS with permanently connected cable, reed contact / float and wall fitting
 83 UV-SR Brass OPS with reed contact / float
 83 UV-SV Brass OPS with variably adjustable junction box
 83 UV-SVR Brass OPS with variably adjustable junction box and reed contact / float

Type LS 300 ... (only Ex relevant designations):

LS 300 Level detector without process connection, test connection and overvoltage protection as well as normal medium temperature range
 LS 300 E... Level detector with screw-in unit
 LS 300 F... Level detector with flange
 LS 300 ...P... Level detector with test connection and without check valve
 LS 300 ...PR... Level detector with test connection and with check valve
 LS 300 ...U... Level detector with overvoltage protection
 LS 300 ...H... Level detector for high medium temperature range
 LS 300 ...HH... Level detector for the highest medium temperature range

Schedule to EU-Type Examination Certificate No. TÜV 00 ATEX 1656 X issue 00

LS 300 ... L...	Level detector for low medium temperature range
LS 300 ... C	Level detector with plastic coating
LS 300 ... Duo	Double level detector
LS 300 ... Steck	Level detector with plug connection
LS 300 ... Tantal	Level detector with at least sensor element made of tantalum
LS 300 ... Trio	Triple level detector
Type SEPARIX-T ...:	
SEPARIX-T H	High-level sensor with sensor tube made of stainless steel for aggressive media
SEPARIX-T L Plus	High-level sensor with sensor tube made of stainless steel for non-aggressive media

Technical data:

Signal- and power circuit	in type of protection "Intrinsic Safety" Ex ia IIC/IIB only for the connection to a certified intrinsically safe circuit Maximum values: $U_i = 30 \text{ V}$ $I_i = 200 \text{ mA}$ $P_i = 1 \text{ W}$ L_i negligibly small C_i negligibly small
---------------------------	--

The types LS 300 ... C with plastic coating are only for gas group IIB allowed.

Permissible ambient temperature range:

The ambient temperature range is -40 °C to $+110 \text{ °C}$. When using a sensor with overvoltage protection, the maximum temperature is $+90 \text{ °C}$.

When used in areas requiring category 1 or 1/2, the following applies:

The process pressure for the media must be between 0.8 bar and 1.1 bar where explosive vapour-air mixtures are present. If no explosive mixtures are present, the equipment may also be operated outside this area according to the manufacturer's specification.

All further data are valid unchanged.

(16) Drawings and documents are listed in the ATEX Assessment Report No. 18 203 228654

(17) Specific Conditions for Use

1. Overfill prevention sensors and level detectors with overvoltage protection do not comply with the dielectric strength requirements according to EN 60079-11, clause 6.3.13. When performing an insulation test on the intrinsically safe circuit, the device must be disconnected.
2. When using the integrated overvoltage protection, integration into the equipotential bonding is required.

(18) Essential Health and Safety Requirements

no additional ones

- End of Certificate -



Instructions in accordance with directive 2014/34/EU

TÜV 00 ATEX 1656 X

Overfill Prevention Sensor type 81 D-Ex ... and 83 UV-...

Level Detector type LS 300 ...

High-Level Sensor type SEPARIX-T ...

Stand: 09.2018

I Range of application

The sensors are intrinsically safe operating equipment for use in explosion hazardous area and serve for detecting the limit level. The overfill prevention sensors serve as part of a overfill prevention device. The level detector is used as part of an overfill protection device, dry run protection or filling control. The high-level sensor is used to detect a fluid back pressure within a light liquid separator.

II Standards

The sensors are designed in accordance with the following European standards

EN 60079-0:2012 + A11:2013	Equipment – General requirements
EN 60079-11:2012	Equipment protection by intrinsic safety "i"
EN 60079-26:2015	Equipment with Equipment Protection Level (EPL) Ga

III Instructions for safe ...

III.a ... use

The sensors are designed as intrinsically safe equipment and are suitable for use in potentially explosive areas. The level detectors LS 300 ... C (coated with plastic) are suitable for the gas groups IIA and IIB. All other level detectors are suitable for all gas groups (IIA, IIB and IIC).

The approval applies to device versions 81 D-Ex ..., 83 UV-..., LS 300 ... and SEPARIX-T ...

III.b ... assembling and dismantling

Assembling and dismantling must solely be carried out with the power disconnected!

For sensors with connection housing the cover of the connection housing may be removed for the electrical installation. After installation, the connection housing must be locked again.

III.c ... installation

The wiring must be carried out only with the power disconnected. Special rules and regulations, including EN 60079-14 and local installation regulations, must be observed.

The sensors can be installed completely inside Zone 0. If the integrated overvoltage protection is used, e.g. LS 300 U, the terminal compartment with overvoltage protection must be installed outside Zone 0.

General information (see also EN 60079-14:2014, Clause 16.3 or EN 60079-25:2010, Clause 12):

The overvoltage protection device must be installed outside, but as close to the border of Zone 0 as technically possible, preferably at a distance of up to 1 m.

If a screw-in unit is used, it must be provided with a suitable sealing material and screwed into the tank coupling. If the sensor tube is permanently connected with a flange, the installation length cannot be changed. The flange shall be provided with a suitable seal and fixed with flange bolts or nuts.

By the process connection, there may be an opening in the boundary wall to the area requiring EPL "Ga". Then, there is the risk of flammable gases release and flame entrance.

If the sensor is supplied without process connection, the installer is responsible for compliance with the EX requirements.

General information (see also EN 60079-26, Clause 4.3):

Attention must be paid, if the sensor is installed in the separating wall between Zone 0 and Zone 1. Then a protection class of at least IP66 or IP67 must be achieved after installation.



When wiring the sensor to the measuring transducer (preferably blue coloured cable), the approved inductance and capacitance of the measuring transducer must not be exceeded.

The sensors have a two-pole screw or plug connection or cable tail. Attention does not need to be paid to polarity.

The integration of the sensors without overvoltage protection into the equipotential bonding is not required. For integration of the sensors with overvoltage protection into the equipotential bonding, a PA terminal is provided.

III.d ... adjustment

No Ex-relevant adjustments are required for operation of the sensors.

III.e ... putting into service

Before putting into service, all devices must be checked for correct connection and installation. The electrical supply, including the connected devices, must be checked.





III.f ... maintenance (servicing and emergency repair)

The sensors are generally maintenance-free. In the case of a defect, this must be returned to the manufacturer or one of its representatives.

The sensors, in particular the probe tip, may be cleaned. Grease-dissolving cleansing agents can be used to remove any firmly clinging grease or oil residues. Sharp-edged objects are unsuitable for cleaning since they could damage the sensor.

When performing an insulation test of the intrinsically safe circuit with 500 V under well-controlled conditions, according to EN 60079-25, Clause 12 it is necessary to disconnect sensors with overvoltage protection since there is no compliance with the requirements for dielectric strength according to EN 60079-11, Clause 6.3.13. For all other sensors, there is compliance between the intrinsically safe circuit and the chassis or, if present, other intrinsically safe circuits with 500 V_{AC}.

IV Equipment marking

1	Manufacturer:	FAFNIR GmbH, 22525 Hamburg	
2	Type designation:	81 D-Ex ... or 83 UV-... or LS 300 ... or SEPARIX-T ...	
3	Certificate number:	TÜV 00 ATEX 1656 X	
4	Ex-Kennzeichnung:	81 D-Ex / 83 UV-... / LS 300 ... / SEPARIX-T ...	
			II 1 G Ex ia IIC T4 Ga II 1/2 G Ex ia IIC T4 Ga/Gb
	81 D-Ex U / LS 300 ...U...		II 1/2 G Ex ia IIC T4 Ga/Gb
	LS 300 ... C		II 1 G Ex ia IIB T4 Ga II 1/2 G Ex ia IIB T4 Ga/Gb
5	CE marking:	 0044	
6	Technical data:	U _i ≤ 30 V I _i ≤ 200 mA P _i ≤ 1 W	



V Technical data

The following electrical input values apply to the sensors:

$$\begin{aligned}U_i &\leq 30 \text{ V} \\I_i &\leq 200 \text{ mA} \\P_i &\leq 1 \text{ W}\end{aligned}$$

The effective internal capacitance and inductance that are externally effective, are negligibly small. If the sensors are supplied with integrated cable, then the electrical characteristics are:

$$\begin{aligned}C_c &= 200 \text{ pF/m} \\L_c &= 1 \text{ }\mu\text{H/m} \\L_c/R_c &= 30 \text{ }\mu\text{H}/\Omega\end{aligned}$$

The sensors may be used in the following ambient temperature range:

$$T_a = -40 \text{ }^\circ\text{C} \dots +110 \text{ }^\circ\text{C}$$

When using a sensor with overvoltage protection, the maximum temperature is +90 °C for the sensor head.

General remark (see also EN 60079-0, Clause 1):

Zone 0 is given only under atmospheric conditions:

Temperature range:	-20 °C ... +60 °C
Pressure range:	0,8 bar ... 1,1 bar
Oxidant:	Air (oxygen content approx. 21 %)

The sensors achieves a degree of protection of:

degree of protection: IP68

The following technical data apply to sensors with overvoltage protection:

The nominal DC spark-over voltage amounts to:

$$U = 350 \text{ V} \pm 20 \%$$

The nominal impulse discharge current amounts to:

$$I = 20 \text{ kA (10} \times \text{ Wave 8/20 } \mu\text{s)}$$

The nominal alternating discharge current amounts to:

$$I = 20 \text{ A (10} \times \text{ @ 50 Hz, 1 s)}$$

The insulation resistance of an overvoltage arrester amounts to:

$$R > 10 \text{ G}\Omega$$

VI Special conditions of use

1. Overfill Prevention Sensor and Level detectors with overvoltage protection do not comply with the dielectric strength requirements according to EN 60079-11, Clause 6.3.13. When performing an insulation test of the intrinsically safe circuit it is therefore necessary to disconnect the device.
2. When using the integrated overvoltage protection, integration into the equipotential bonding is required.

Translation

(1) **EU-Type Examination Certificate**

(2) Equipment and protective systems intended for use in potentially explosive atmospheres, **Directive 2014/34/EU**



(3) **Certificate Number** TÜV 00 ATEX 1641 X **issue:** 01

(4) for the product: Measuring Transducer type LS 500 ...

(5) of the manufacturer: **FAFNIR GmbH**

(6) Address: Schnackenburgallee 149 c, 22525 Hamburg, Germany

Order number: 8003011043

Date of issue: 2021-08-10

(7) The design of this product and any acceptable variation thereto are specified in the schedule to this EU-Type Examination Certificate and the documents therein referred to.

(8) The TÜV NORD CERT GmbH, Notified Body No. 0044, in accordance with Article 17 of the Directive 2014/34/EU of the European Parliament and the Council of 26 February 2014, certifies that this product has been found to comply with the Essential Health and Safety Requirements relating to the design and construction of products intended for use in potentially explosive atmospheres given in Annex II to the Directive.

The examination and test results are recorded in the confidential ATEX Assessment Report No. 21 203 254815.

(9) Compliance with the Essential Health and Safety Requirements has been assured by compliance with:

EN IEC 60079-0:2018

EN 60079-11:2012

except in respect of those requirements listed at item 18 of the schedule.

(10) If the sign "X" is placed after the certificate number, it indicates that the product is subject to the Specific Conditions for Use specified in the schedule to this certificate.

(11) This EU-Type Examination Certificate relates only to the design, and construction of the specified product. Further requirements of the Directive apply to the manufacturing process and supply of this equipment. These are not covered by this certificate.

(12) The marking of the product shall include the following:

 **II (1) G [Ex ia Ga] IIC**

TÜV NORD CERT GmbH, Langemarckstraße 20, 45141 Essen, notified by the central office of the countries for safety engineering (ZLS), Ident. Nr. 0044, legal successor of the TÜV NORD CERT GmbH & Co. KG Ident. Nr. 0032

Head of the notified body



Roder

Hanover office, Am TÜV 1, 30519 Hannover, Tel. +49 511 998-61455, Fax +49 511 998-61590

(13) **SCHEDULE**

(14) **EU-Type Examination Certificate No. TÜV 00 ATEX 1641 X issue 01**

(15) Description of product

The measuring transducer LS 500 ... is an associated apparatus and is used to supply intrinsically safe sensors, which can be used in a potentially explosive atmosphere. Furthermore, the measuring transducer serves to forward electrical signals between the non-safe and intrinsically safe area. The measuring transducer is primarily used as part of an overfill prevention or a dry-running protection.

The measuring transducer type LS 500 ... may also be manufactured in accordance with the test specifications listed in the ATEX test report.

The changes concern the electrical data as well as the removal of the types LS 500 19" ... and LS 500 LPG. In addition, the internal structure of the measuring transducer has changed. Furthermore, the measuring transducers were evaluated according to the latest standards.

Type designation

LS 500 ... Measuring transducer in plug-in enclosure
 LS 500 H ... Measuring transducer in mounting rail enclosure
 LS 500 H SIL ... Measuring transducer in mounting rail enclosure with functional safety

Electrical Data

Type LS 500 ...

Power supply circuit
 (terminals 15, 14, 13/12) $U = 24/115/230 \text{ V a.c. } \pm 10 \%, 40...60 \text{ Hz, app. } 4 \text{ VA}$
 $U = 24 \text{ V d.c. } \pm 20 \%, \text{ app. } 5 \text{ W}$
 $U_m = 33 \text{ V at } 24 \text{ V a.c. resp. } 24 \text{ V d.c.}$
 $U_m = 130 \text{ V at } 115 \text{ V a.c.}$
 $U_m = 253 \text{ V at } 230 \text{ V a.c.}$

Type LS 500 H ...

Power supply circuit
 (contacts -, +, □) $U = 23...30 \text{ V d.c., app. } 8 \text{ W}$
 $U_m = 253 \text{ V}$

Type LS 500 ..., type LS 500 H ...

Sensor circuits
 (terminals 1 and 2, resp.
 contacts 1, 1, 2 and 2) in type of protection "Intrinsic Safety" Ex ia IIC/IIB
 Maximum values: $U_o = 15.8 \text{ V}$
 $I_o = 159 \text{ mA}$
 $R = 156.8 \Omega$
 $P_o = 993 \text{ mW}$
 Characteristic line: trapezoidal
 $C_i = 1.2 \text{ nF}$
 L_i negligibly small

The maximum permissible values pairs of the external capacitances (C_o) and inductances (L_o) have to be taken from the following table:

	Ex ia IIC		Ex ia IIB	
C_o	230 nF	260 nF	1,3 µF	1,6 µF
L_o	440 µH	200 µH	6,5 mH	5 mH

Schedule to EU-Type Examination Certificate No. TÜV 00 ATEX 1641 X issue 01

Type LS 500 L ..., type LS 500 H L ...

Sensor circuits in type of protection "Intrinsic Safety" Ex ia IIC/IIB
 (terminals 1 and 2, resp. contacts 1, 1, 2 and 2)

Maximum values: $U_o = 15.8 \text{ V}$
 $I_o = 26 \text{ mA}$
 $R = 950 \Omega$
 $P_o = 164 \text{ mW}$
 Characteristic line: trapezoidal
 $C_i = 1.2 \text{ nF}$
 L_i negligibly small

The maximum permissible values pairs of the external capacitances (C_o) and inductances (L_o) have to be taken from the following table:

	Ex ia IIC		Ex ia IIB	
	C_o	280 nF	310 nF	1,8 μF
L_o	10 mH	5 mH	20 mH	10 mH

Type LS 500 ..., type LS 500 H ..., type LS 500 H SIL ...

Output circuits (terminals 6 to 11, resp. contacts Output 1 and 2, resp. contacts Output SIL Error)	Alternating voltage	Direct voltage
	$U \leq 250 \text{ V}$	$U \leq 250 \text{ V}$
	$I \leq 5 \text{ A}$	$I \leq 5 \text{ A}$
	$P \leq 100 \text{ VA}$	$P \leq 100 \text{ W}$
	$\cos \varphi \geq 0.7$	

Type LS 500 H SIL ...

Output circuit (contacts Output Sensor)	Alternating voltage	Direct voltage
	$U \leq 42 \text{ V}$	$U \leq 60 \text{ V}$
	$I \leq 5 \text{ A}$	$I \leq 5 \text{ A}$
	$P \leq 100 \text{ VA}$	$P \leq 100 \text{ W}$
	$\cos \varphi \geq 0.7$	

Type LS 500 H ...

Communication circuit (contacts A, B and G)	$U < 12 \text{ V DC}$
	$U_m = 253 \text{ V}$

The signal transmitter circuits of type LS 500 ... are safely galvanically separated from the supply and output circuits up to a peak value of the nominal voltage of 375 V.

The output circuits of type LS 500 H ... are safely galvanically separated from all other circuits up to a peak value of the nominal voltage of 375 V.

The output circuit SIL Error of type LS 500 H SIL ... is safely galvanically separated from all other circuits up to a peak value of the nominal voltage of 375 V. The output circuit Sensor is safely galvanically separated from all other circuits up to a peak value of the nominal voltage of 60 V.

Schedule to EU-Type Examination Certificate No. TÜV 00 ATEX 1641 X issue 01

(16) Drawings and documents are listed in the ATEX Assessment Report No. 21 203 254815

(17) Specific Conditions for Use

1. Measuring transducer LS 500 H ... is to be installed in such a way that the connecting terminals for intrinsically safe circuits are isolated from other circuits (e. g. by means of distance, thread measure ≥ 50 mm), to conform to the requirements of EN 60079-11, clause 6.2.
2. The potential equalization terminal of measuring transducer LS 500 H ... must be connected with the potential equalization of the potentially explosive area. This connects the intrinsically safe circuit with the earth potential and potential equalization must exist in the entire area in which the intrinsically safe circuit is installed.

(18) Essential Health and Safety Requirements

no additional ones

- End of Certificate -



Instructions in accordance with directive 2014/34/EU

TÜV 00 ATEX 1641 X

Measuring Transducer type LS 500 ...

Edition: 07.2021

I Range of application

The measuring transducer LS 500 ... is an associated apparatus and is used to supply intrinsically safe sensors that can be used in potentially explosive atmospheres. Furthermore, the measuring transducer is used to transmit electrical signals between the non-intrinsically safe and intrinsically safe area. Mainly the measuring transducer is used as part of an overfill protection or dry running protection.

II Standards

The measuring transducer is designed in accordance with the following European standards

EN IEC 60079-0:2018	Equipment – General requirements
EN 60079-11:2012	Equipment protection by intrinsic safety "i"

III Instructions for safe ...

III.a ... use

The measuring transducer serves as associated apparatus and is not for use in potentially explosive areas. The intrinsically safe sensor circuit of the measuring transducer can be led in zone 0 and is suitable for all gas groups (IIA, IIB and IIC).

The approval applies to the equipment types LS 500 ...

III.b ... assembling and dismantling

The assembling and dismantling must solely be carried out with the power disconnected!

Measuring transducer type LS 500 ... in the plug-in enclosure

For wall mounting the measuring transducer the upper part of the enclosure must be removed from the lower part. For this, loosen the two screws from the upper part of the enclosure and pull apart both parts. After the installation, the upper part of the enclosure is remounted onto the lower part and tightened by using the two enclosure screws.

Measuring transducer type LS 500 H ... in mounting rail enclosure

To press the test button, the upper cover must be turned up. Further disassembly should not be attempted and would probably damage the measuring transducer and therefore invalidate the approval.



III.c ... installation

All wiring operations must solely be carried out with the power disconnected. Special rules and regulations, including EN 60079-14 and local installation regulations, must be observed.

The measuring transducer must be installed outside potentially explosive atmospheres/areas. The wiring from the sensor to the measuring transducer (preferably blue coloured cable) must not exceed the permissible inductance and capacitance according to section V.

Measuring transducer type LS 500 ... in the plug-in enclosure

The measuring transducer is suitable for wall mounting.

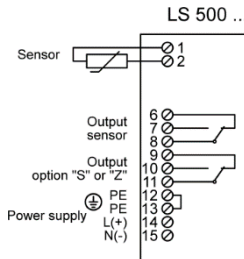

Measuring transducer type LS 500 H ... in mounting rail enclosure

The measuring transducer is provided for installation on a mounting rail. It must be ensured that the distance of the intrinsically safe electric circuits to other equipment is observed. For compliance to the intrinsic safety the measuring transducer must be bonded into the potential equalization.

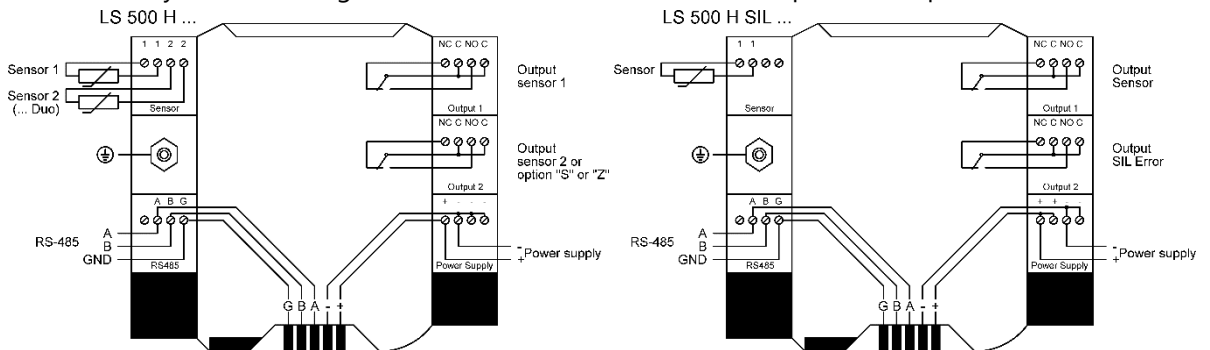

III.d ... adjustment

To operate the measuring transducer Ex relevant safety adjustments are not necessary.

III.e ... putting into service

Before putting into service, all equipment must be checked to ensure it is properly connected and installed. The power supply, as well of connected equipment, must be checked.

III.f ... maintenance (servicing and emergency repair)

Generally, the measuring transducer is maintenance-free. In case of a defect it must be send back to FAFNIR or one of his representations.

When performing the insulation test of the intrinsic safe sensor circuit - under well-controlled conditions - the measuring transducer type LS 500 H ... (mounting rail enclosure) must be disconnected since there is no conformity with the requirements for dielectric strength according to EN 60079-11, Clause 6.3.13. Conformity exists for all other measuring transducers.



IV Equipment marking

- 1 Manufacturer: FAFNIR GmbH, 22525 Hamburg
- 2 Type designation: LS 500 ...
- 3 Certificate number: TÜV 00 ATEX 1641 X
- 4 Ex marking: II (1) G [Ex ia Ga] IIC
- 5 CE marking: 0044
- 6 Technical data: See instructions for technical data

V Technical data

The **power supply** for the measuring transducer, depending on model

Type LS 500 ...

- U = 24 V_{AC}/115 V_{AC}/230 V_{AC} ± 10 %; 40 Hz ... 60 Hz; < 4 VA; or
- U = 24 V_{DC} ± 20 %; < 5 W

The power supply is safely galvanically isolated from the intrinsically safe sensor circuit up to a peak crest value of 375 V.

Type LS 500 H ...

- U = 23 V_{DC} ... 30 V_{DC}; < 8 W

The safety-related maximum voltage is

	LS 500 ...	LS 500 H ...
24 V_{DC}	U _m = 33 V	U _m = 253 V
24 V_{AC}	U _m = 33 V	-
115 V_{AC}	U _m = 130 V	-
230 V_{AC}	U _m = 253 V	-

Table V: Maximum safety-related voltage of the power supply

The **sensor circuits** are in protection intrinsic safety "ia" designed with a trapezoidal output characteristic. Output values per electric circuit are

Measuring transducer type LS 500 ... for level detectors with PTC thermistor, e. g. type LS 300 ...

- U_o ≤ 15.8 V
- I_o ≤ 159 mA
- P_o ≤ 993 mW
- R_q ≥ 156.8 Ω
- C_i ≤ 1.2 nF

	Gas group IIC		Gas group IIB	
L _o ≤	440 μH	200 μH	6.5 mH	5 mH
C _o ≤	230 nF	260 nF	1.3 μF	1.6 μF

The maximum values of the parameter pairings may simultaneously be used as concentrated capacitances (minus C_i) and concentrated inductances.



Measuring transducer type LS 500 ...L... for level detectors with switch-point, e.g. type LOF 1.1... Ex ...

$$\begin{aligned}U_o &\leq 15.8 \text{ V} \\I_o &\leq 26 \text{ mA} \\P_o &\leq 164 \text{ mW} \\R_q &\geq 950 \text{ } \Omega \\C_i &\leq 1.2 \text{ nF}\end{aligned}$$

	Gas group IIC		Gas group IIB	
$L_o \leq$	10 mH	5 mH	20 mH	10 mH
$C_o \leq$	280 nF	310 nF	1.8 μ F	2.2 μ F

The maximum values of the parameter pairings may simultaneously be used as concentrated capacitances (minus C_i) and concentrated inductances.

Potential-free contacts are available as **output circuits**.

Type LS 500 ...

$$\begin{aligned}\text{AC} & \quad U \leq 250 \text{ V}; I \leq 5 \text{ A}; P \leq 100 \text{ VA}; \cos \varphi \geq 0,7 \\ \text{DC} & \quad U \leq 250 \text{ V}; I \leq 5 \text{ A}; P \leq 100 \text{ W}\end{aligned}$$

The output circuits are safely galvanically isolated from the intrinsically safe sensor circuits up to a peak crest value of 375 V.

Type LS 500 H SIL ...

The following values apply only to the sensor relay. For the SIL error relay, values for LS 500 ... are valid

$$\begin{aligned}\text{AC} & \quad U \leq 42 \text{ V}; I \leq 5 \text{ A}; P \leq 100 \text{ VA}; \cos \varphi \geq 0,7 \\ \text{DC} & \quad U \leq 60 \text{ V}; I \leq 5 \text{ A}; P \leq 50 \text{ W}\end{aligned}$$

The signal voltage of **communication interface** RS-485 of the measuring transducer LS 500 H ... amounts to

$$\begin{aligned}U &< 12 \text{ V} \\U_m &= 253 \text{ V}\end{aligned}$$

The sensor can be used in the following **ambient temperature range**:

$$T_a = -25 \text{ }^\circ\text{C} \dots +50 \text{ }^\circ\text{C}$$

The measuring transducer achieves a **degree of protection provided by enclosure** of

LS 500 ...	IP40
LS 500 H ...	IP30

VI Special conditions of use

1. Measuring transducers LS 500 H ... are to be installed in such a way that the connecting terminals for intrinsically safe circuits are isolated from other circuits (e.g. by means of distance, thread measure ≥ 50 mm), to comply to the requirements of EN 60079-11, Clause 6.2.
2. The potential equalization terminal of measuring transducer LS 500 H ... must be connected with the potential equalization of the potentially explosive area. This connects the intrinsically safe circuit with the earth potential and potential equalization must exist in the entire area in which the intrinsically safe circuit is installed.

ZERTIFIKAT CERTIFICATE

Hiermit wird bescheinigt, dass die Firma / *This is to certify, that the company*

FAFNIR GmbH
Schnackenburgallee 149 c
22525 Hamburg
Deutschland

die Anforderungen der folgenden Normen erfüllt.
meets the requirements of the following standards.

Geprüft nach **EN 61508:2010, SIL 2**
Tested in accordance with

Beschreibung des Produktes **Messumformer mit dem Standaufnehmer LS 300**
(Details s. Anlage 1) *Measuring transducer with the level detector LS 300*
Description of product
(Details see Annex 1)

Typbezeichnung **LS 500 H SIL**
Type designation

Bemerkung **Bitte beachten Sie auch die Hinweise in der Anlage**
Remark *Please also pay attention to the Annex*

Dieses Zertifikat bescheinigt das Ergebnis der Prüfung an dem vorgestellten Prüfgegenstand. Eine allgemein gültige Aussage über die Qualität der Produkte aus der laufenden Fertigung kann hieraus nicht abgeleitet werden.
This certifies the result of the examination of the product sample submitted by the manufacturer. A general statement concerning the quality of the products from the series manufacture cannot be derived there from.

Registrier-Nr. / *Registered No.* 44 799 13752003
Prüfbericht Nr. / *Test Report No.* 3522 3309
Aktenzeichen / *File reference* 8000485153

Gültigkeit / *Validity*
von / *from* 2018-10-12
bis / *until* 2023-10-11

Zertifizierungsstelle der TÜV NORD CERT GmbH
Certification body of TÜV NORD CERT GmbH

Essen, 2018-10-12

TÜV NORD CERT GmbH Langemarckstraße 20 45141 Essen www.tuev-nord-cert.de machinery@tuev-nord.de

Bitte beachten Sie auch die umseitigen Hinweise
Please also pay attention to the information stated overleaf

Hinweise zum TÜV NORD- Zertifikat

Dieses TÜV NORD - Zertifikat gilt nur für die umseitig bezeichnete Firma und das angegebene Produkt. Es kann nur von der Zertifizierungsstelle auf Dritte übertragen werden.

Notwendige Bedienungs- und Montageanweisungen müssen jedem Produkt beigelegt werden.

Jedes Produkt muss deutlich einen Hinweis auf den Hersteller oder Importeur und eine Typenbezeichnung tragen, damit die Identität des geprüften Baumusters mit den serienmäßig in den Verkehr gebrachten Produkten festgestellt werden kann.

Der Inhaber des TÜV NORD - Zertifikates ist verpflichtet, die Fertigung der Produkte laufend auf Übereinstimmung mit den Prüfbestimmungen zu überwachen und insbesondere die in den Prüfbestimmungen festgelegten oder von der Zertifizierungsstelle geforderten Kontrollprüfungen ordnungsgemäß durchzuführen.

Bei Änderungen am geprüften Produkt ist die Zertifizierungsstelle umgehend zu verständigen.

Bei Änderungen und bei befristeten Zertifikaten ist das Zertifikat nach Ablauf der Gültigkeit urschriftlich an die Zertifizierungsstelle zurückzugeben. Die Zertifizierungsstelle entscheidet, ob das Zertifikat ergänzt werden kann oder ob eine erneute Zertifizierung erforderlich ist.

Für das TÜV NORD - Zertifikat gelten außer den vorgenannten Bedingungen auch alle übrigen Bestimmungen des allgemeinen Vertrages. Es hat solange Gültigkeit, wie die Regeln der Technik gelten, die der Prüfung zu Grunde gelegt worden sind, sofern es nicht auf Grund der Bedingungen des allgemeinen Vertrages früher zurückgezogen wird.

Dieses TÜV NORD - Zertifikat verliert seine Gültigkeit und muss unverzüglich der Zertifizierungsstelle zurückgegeben werden, falls es ungültig wird oder für ungültig erklärt wird.

Hints to the TÜV NORD - Certificate

This TÜV NORD - certificate only applies to the firm stated overleaf and the specified product. It may only be transferred to third parties by the certification body.

Each product must be accompanied by the instructions which are necessary for its operation and installation.

Each product must bear a distinct indication of the manufacturer or importer and a type designation so that the identity of the tested sample may be determined with the product launched on the market as a standard.

The bearer of the TÜV NORD - Certificate undertakes to regularly supervise the manufacturing of products for compliance with the test specifications and in particular properly carry out the checks which are stated in the specifications or required by the test laboratory.

In case of modifications of the tested product the certification body must be informed immediately.

In case of modifications and expiration of validity the original certificate must be returned to the certification body immediately. The certification body decides if the certificate can be supplemented or whether a new certification is required.

In addition to the conditions stated above, all other provisions of the General Agreement are applicable to the TÜV NORD - Certificate. It will be valid as long as the rules of technology on which the test was based are valid, unless revoked previously pursuant to the provisions of the General Agreement.

This TÜV NORD - Certificate will become invalid and shall be returned to the certification body immediately in the event that it shall expire without delay when it has expired or revoked.

ANLAGE ANNEX

Anlage 1, Seite 1 von 2
Annex 1, page 1 of 2

zum Zertifikat Registrier-Nr. / to Certificate Registration No. 44 799 13752003

Allgemeine Angabe: <i>General information:</i>	Siehe Seite 1 des Zertifikats <i>See page 1 of the certificate</i>
Versorgungsspannung: <i>Supply voltage:</i>	23 V DC ... 30 V DC, < 8 W
Schalterspannung: <i>Switching voltage:</i>	AC $U \leq 250$ V; $I \leq 5$ A; $P \leq 100$ VA; $\cos \phi \geq 0,7$ DC $U \leq 250$ V; $I \leq 5$ A; $P \leq 100$ W
Umgebungstemperatur: <i>Ambient temperature:</i>	-25 °C ... +50 °C
Sicherheitsfunktion: <i>Safety function:</i>	Überfüllsicherung und Trockengehschutz <i>Overfill prevention and dry-run protection</i>
Sicherheitsgerichteter Ausgang: <i>Safety-related output:</i>	Output 1
Hardwareversion: <i>Hardware version:</i>	1.1.0.255
Softwareversion: <i>Software version:</i>	1.2.0.255



Zertifizierungsstelle der TÜV NORD CERT GmbH
Certification body of TÜV NORD CERT GmbH

Essen, 2018-10-12

ANLAGE ANNEX

Anlage 1, Seite 2 von 2
Annex 1, page 2 of 2

zum Zertifikat Registrier-Nr. / to Certificate Registration No. 44 799 13752003

Typenschlüssel:
Type designation:

Typ	Funktion
LS 500 H SIL	Messumformer als Überfüllsicherung mit SIL 2 - Zertifizierung
LS 500 H SIL T	Messumformer als Trockengehschutz mit SIL 2 - Zertifizierung

Bemerkung 1:
Remark 1:

Der Einsatz des LS 500 H SIL hat unter Beachtung der durch den Hersteller vorgegebenen Sicherheitshinweise in der Technischen Dokumentation und im Sicherheitshandbuch der jeweils aktuellen Fassung zu erfolgen.

The safety instructions of the manufacturer in the Technical Documentation / safety manual in its current valid version must be taken into consideration when using the LS 500 H SIL.

Bemerkung 2:
Remark 2:

Für eine vollständige Beurteilung der funktionalen Sicherheit des Gesamtsystems müssen alle Anforderungen der EN 61508 auf alle Teilsysteme – und somit auf die gesamte Sicherheitsfunktion – angewendet werden.

To accomplish a complete functional safety assessment of the whole system, all requirements of EN 61508 must be applied to all subsystems – and therefore to the overall safety function.



Zertifizierungsstelle der TÜV NORD CERT GmbH
Certification body of TÜV NORD CERT GmbH

Essen, 2018-10-12

Safety manual in accordance with series of standards EN 61508

Level detector type LS 300 ... and Measuring Transducer type LS 500 H SIL ... Edition: 09.2018

I Range of application

The level detector type LS 300 ... and the measuring transducer type LS 500 H SIL ... are suitable for areas in which a safety-related subsystem (overflow protection or dry-running protection) according to EN 61508 with SIL 2 is mandatory.

II Standards

The equipment is designed in accordance with the following standards

EN 61508:2010, all parts	Functional safety of electrical/electronic/programmable electronic safety-related systems
EN 61326-3-2:2008	Immunity requirements for safety-related systems and for equipment intended to perform safety-related functions (functional safety) – Industrial applications with specified electromagnetic environment

III Instructions for safe ...

III.a ... use

This safety guide applies to all level detectors type LS 300 ... and the following measuring transducers from hardware version 1.0.1.255 and from firmware version 1.0.1.255:

LS 500 H SIL	Measuring transducer as overflow prevention, assessed according to functional safety
LS 500 H SIL T	Measuring transducer as dry-run protection, assessed according to functional safety

From firmware version 1.1.0.255, the firmware version can be read with MODBUS-RTU Protocol from the transmitter via the RS-485 interface. To do this, use the Function Code 03 (Read Holding Registers) with following addresses:

Address	Content	Meaning
0x0040	0x0101	Version number digit 1 (main version) and digit 2 (features)
0x0041	0x00FF	Version number digit 3 (bug fixes) and digit 2 (release)

Table III.a: Storage of the version number in registers

The safety function is mapped by the sensor relay. This not only shows the alarm condition if the relay is deactivated, but also if there is a diagnostic error. The SIL Error relay and the SIL Error LED additionally indicate the SIL Error but are not part of the safety function.

The response times of the level detector LS 300 ... with measuring transducer LS 500 H SIL ... are maximal two seconds when used as overflow protection and approximately (typically at room temperature) 20 s when used as dry-run protection.

The level detector type LS 300 ... was subjected to a vibration test in accordance with VdTÜV-information sheet overflow protection 100-part 2. It is therefore suitable for vibration environments with 10 Hz to 55 Hz and 2 g. A shock test was not performed.

A vibration and shock test were not carried out with the measuring transducer LS 500 H SIL ...

III.b ... assembling and dismantling

For level detectors with connection housings only the cover of the housing may be removed for the electrical installation. After the installation the connection housing must be closed again.

At measuring transducers, only the cover of the housing may be removed to operate the test button.

III.c ... installation

The installation must be carried out only with the power disconnected!

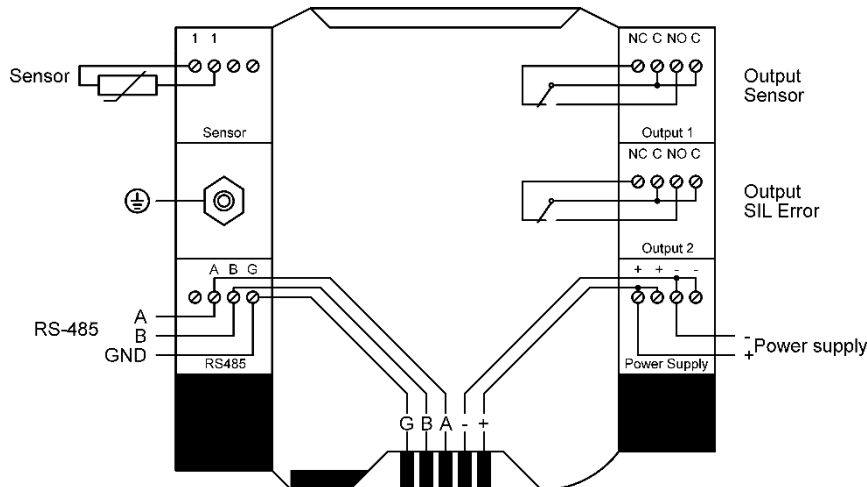

Figure III.c: Wiring diagram

III.d ... adjustment

No SIL-relevant adjustments are required for operation of the sensors.

III.e ... putting into service

Before putting into service, all devices must be checked of right installation and connection. The electrical supply, as well of connected devices, must be checked.

When using the measuring transducer as dry run protection, it should be ensured that the sensor relay activates immediately after switching on.

III.f ... maintenance (servicing and emergency repair)

Device is generally maintenance-free. In case of a defect, it must be send back to FAFNIR or one of its representations.

Nevertheless, the functionality of the system should be checked at appropriate intervals, but at least once a year. The operator shall be responsible for the type and frequency of inspection within the specified period.

If the level detector is surfaced, the PTC thermistor in the level detector can be cooled by means of the test button on the measuring transducer (corresponds to the immersion). If the level detector is immersed, remove it from the medium and wait until the PTC thermistor is heated up.

Pressing the test button of a surfaced level detector switches to the "immersed" state after less than a second and the sensor relay is deactivated. If the button is still being pressed, then after about five seconds (two seconds with firmware version 1.0.1.255) additionally the SIL-Error (scanner transistor) is triggered and the SIL relay is activated.

If a SIL Error has occurred, the measuring transducer must be de-energized to force a restart.

To facilitate the diagnostics in case of a SIL error, a flashing code is output with the "Error" LED as of firmware version 1.2.0.255 and hardware version 1.1.0.255, whereby the actual cause can be identified. The corresponding blink code is issued continuously, each with a short pause. The following blink codes are used:

SIL error	Blink code
Memory	1
Checksum	2
Relay	3
Scanner resistance	4
Scanner transistor	5
Isolation	6

Table III.f: The blink codes of LED "Error"

To ensure that a short circuit can be detected directly on the level sensor even with a higher cable length, the resistance value must be $< 30 \Omega$ (with firmware version 1.0.1.255 $< 2.5 \Omega$).

An insulation failure on the level sensor is only conditionally recognized and not displayed up to and including firmware version 1.1.0.255 and hardware version 1.0.2.255. From firmware version 1.2.0.255 and hardware version 1.1.0.255 this error is detected and displayed.

IV Safety Ratings

Parameter	Value			
Safety Integrity Level	SIL 2			
Hardware Fault Tolerance	HFT = 0			
Failure rate	$\lambda_{SD} =$ 1.92E-06	$\lambda_{SU} =$ 4.44E-08	$\lambda_{DD} =$ 2.12E-06	$\lambda_{DU} =$ 6.83E-07
average frequency of dangerous failure per hour	PFH = 6.83E-07			
mean time to restoration	MTTR = 8 h			
Interval of the retest	$T_1 = 1$ year			
Architecture	1001			

Table IV: Safety related codes

V Additional requirements for software elements

There are no requirements for software elements.



Blank page



FAFNIR GmbH
Schnackenburgallee 149 c
22525 Hamburg, Germany
T: +49 / 40 / 39 82 07-0
F: +49 / 40 / 390 63 39
E-mail: info@fafnir.com
Web: www.fafnir.com
