

Overflow Prevention System Accessories

1.4

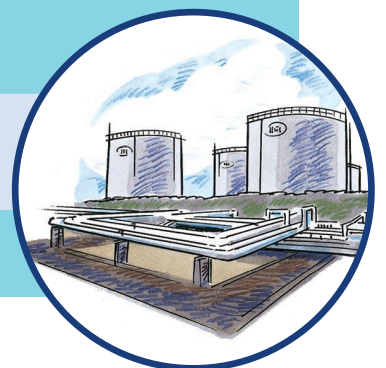

The Accessories for FAFNIR Overfill Prevention Systems

Contents

- Acknowledgement unit type QE 200
- Collective acknowledgement unit type SAM 8 / 25
- Acoustic signal type HPW 110
- Acoustic signal with integrated alarm lamp type HR
- Alarm lamp type W
- Alarm lamp type R4
- Testing device type FS 82 T / type FS 92 T
- Counter-plug type S28
- Rack 19"
- Plastic housing 19"
- Female connector according to DIN 41612 model F
- Control unit for overfill prevention systems



Acknowledgement unit type QE 200

Advantages of FAFNIR's Technology

- Totally compatible to FAFNIR's overfill prevention systems
- Optimized use of the transducers
- Improved operating comfort for tank groups
- Increased alarm intensity

Acknowledgement Unit QE 200

In addition the acknowledgement unit provides the transducers LS 500 and NB 220 H with the acknowledgement function and optical alarm.

Function

The acoustic alarm can be acknowledged and stopped via push-button. The optical alarm remains active until the threshold cause is eliminated.

Installation Advice

Mounting on wall or in control unit.

Design

The acknowledgement unit consists of:

- Acknowledgement button
- Lamps (operation, alarm)
- Terminals
- Housing

Installation Advice

The acknowledgement unit may not be operated in an explosive atmosphere.

It must be installed in closed rooms or in a housing, protection class IP 54.

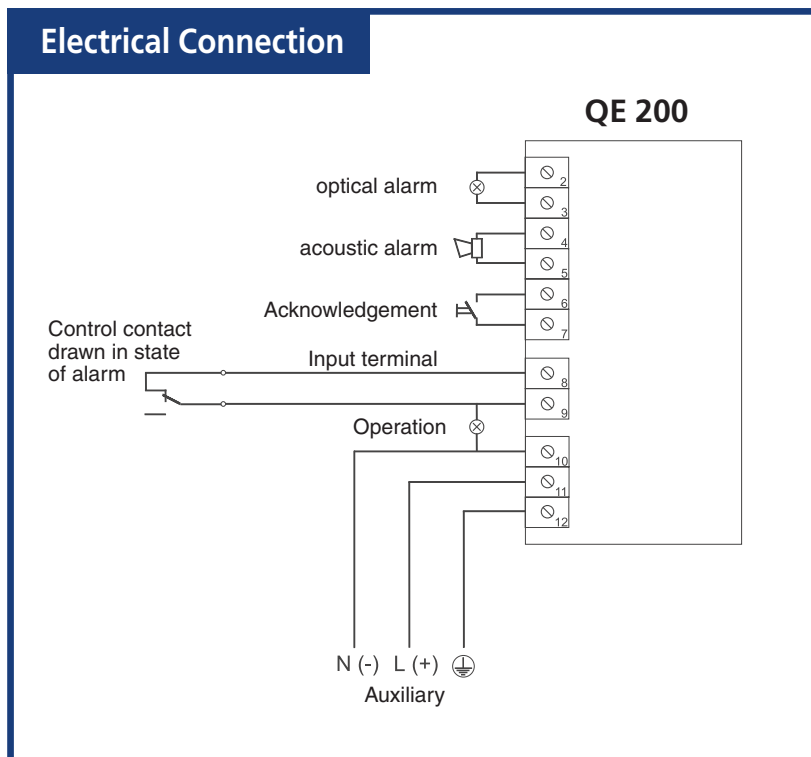

Technical Data

Operating data:

- Auxiliary power: 24 V, 110 V, 230 V; 50 Hz or 24 V DC
- Power consumption: 2 VA; 2 W
- Ambient temperature: -25 °C to +60 °C
- Protection type of housing: IP 40

Outputs:

- Switch auxiliary power
- 1 x optical alarm, 1 x acoustic alarm
- Load: altogether max. 100 W

Inputs:

- Auxiliary power charged
- Acknowledgement button (normally open contact)
- Switching input (normally open contact)

Dimensions:

- H 110 x W 50 x D 125

Collective Acknowledgement Unit Type SAM 8 / 25

Max. 8 or 25 transducers can be connected to the collective acknowledgement unit. The switching signal of an individual transducer from a cascade triggers an acoustic alarm.

Function

The acoustic alarm can be acknowledged and stopped by push-button. The optical alarm remains active until the threshold cause is eliminated.

If the alarm is repeated or a second transducer is triggered, the acoustic alarm is actuated again and can be acknowledged.

Installation Possibility

To be mounted in an electrical cabinet.

Installation Advice

The collective acknowledgement unit may not be operated in an explosive atmosphere. It must be installed in closed rooms or outside in a housing, protection class at least IP 54.

Technical Data

Operating data:

- Auxiliary power: 230 V, 50 Hz
- Power consumption: 8 VA
- Ambient temperature: +5 °C to +40 °C
- Protection type of housing: IP 20

Output:

- 230 V switched
- 1 x acoustic alarm
- load: maximal 1 A

Inputs:

- Acknowledgement button (normally closed contact); switching capacity: 230 V, 50 Hz, 10 mA
- Switching input; switching capacity: 230 V, 50 Hz, 1.7 mA

Dimensions:

- H 75 x W 100 x D 63

Acoustic Signal Type HPW 110

Strong acoustic alarm for outdoor operation.

Installation Possibility

- Wall mounting.

Installation Advice

- The acoustic signal may not be operated in an explosive atmosphere.

Technical Data

Operating data:

- Auxiliary power: 230 V / 50 Hz, 24 V / 50Hz, 24 V / DC
- Power consumption: 20 VA
- Sonic pressure: 108 dBA
- Ambient temperature: -20 °C to +60 °C
- Protection type of housing: IP 55
- 100% ED

Dimensions:

- H 356 x Ø 152

Acoustic Signal Type HR

Strong acoustic and optical alarm for indoor and outdoor operation.

Function

When connected to an acknowledgement unit the acoustic and the optical alarm can be switched individually.

Installation Possibility

Wall mounting

Installation Advice

The horn may not be operated in an explosive atmosphere.

Technical Data

Operating data:

- Auxiliary power: 230 V, 50 Hz
- Power consumption: 12 VA
- Sonic pressure: 92 dBA
- Ambient temperature: -20 °C to +50 °C
- Protection type of housing: IP 33
- 100% ED

Dimensions:

- H 256 x Ø 78

Alarm Lamp Type W

Optical alarm for indoor and outdoor operation.

Installation Possibility

Wall mounting.

Notes for Built-in

The lamp may not be operated in an explosive atmosphere. The alarm lamp must be provided with a bulb, which is not included in the scope of delivery.

Installation Advice

Operating data:

- Auxiliary power: 230 V, 50 Hz; max. 100 W
- Ambient temperature: -25 °C to +50 °C
- Protection type of housing: IP 43

Dimensions:

- H 185 x W 132 x D 114

Rotating Alarm Lamp Type R4

Strong optical alarm for indoor and outdoor operation.

Installation Possibility

Wall mounting.

Installation Advice

The lamp may not be operated in an explosive atmosphere.

Technical Data

Operating data:

- Auxiliary power: 230 V, 50 Hz
- Motor: 5 W
- Lamp red: 25 W
- Ambient temperature: -25 °C to +50 °C
- Protection type of housing: IP 54

Dimensions:

- H 200 x Ø 151

Testing Device Type FS 82 / 92 T

With the portable testing device level sensors with pneumatic test connection can be physically checked.

Function

The level sensor is connected to a pressure hose with coupling. A test gas is fed to the sensor via a nozzle for a short time cooling it down. The signal and alarm unit is triggered.

Design

The testing device consists of:

- Pressure container
- Gas connection
- Terminals
- Internal pressure reducer
- Housing

Note

The testing devices are suitable for operation in explosive atmospheres.

Technical Data

Operating data:

- Pressure container FS 82 T: 1 litre bottle nitrogen cover gas, 200 bar
- Pressure container FS 92 T: 2 litre, max. 10 bar, to be filled by the user
- Ambient temperature: -25 °C to +60 °C

Outputs:

- FS 82 T: pressure outlet, 6 bar, time-controlled 1 x 2 seconds, 1 x permanent
- FS 92 T: pressure outlet, 3 bar, permanent

Inputs:

- Electrical connection to the level detector

Dimensions:

- FS 82 T: H 400 x Ø 300,
- FS 92 T: H 285 x Ø 190

Weight:

- FS 82 T: 9 Kg
- FS 92 T: 4 Kg

Counter-Plug S28

For level detector type LS 300 with electrical plug-in connection

Technical Data

- Protection type of housing: IP 55
- 4-polar plus earth conductor
- Material: Aluminium die casting
- Dimensions: H 125 x Ø 50

Rack 19"

For transducer, type LS 500 19"

Installation Possibility

Integration into 19"-Systems

Design

The rack consists of:

- Frame with cover
- Guide rails
- Female connectors
- Optional wiring and cable end

Note

The purchase order must include information about the type of transducer used.

Technical Data

- Protection type of housing: IP 20
- Material: Aluminium
- Dimensions: 84 TE, 3 HE
- Length cable end: 5 m

Plastic Housing 19"

For transducer, type LS 500 19"

Installation Possibility

Wall mounting or DIN rail mounting for one transducer.

Design

The plastic housing includes:

- Guide rails
- Female connectors
- Terminals

Note

The purchase order must include information about the used type of transducer.

Technical Data

- Material: ABS
- Protection type of housing: IP 40; Dimensions: H 136 x W 68 x D 236 or
- Protection type of housing: IP 65; Dimensions: H 136 x W 68 x D 261 or
- Other plastic housings on request

Female Connector according to DIN 41612 Model F

For transducers, type LS 500 19"

Technical Data

- 32-polar soldered connection
- Material: Polyamide 6.

Control Units for Overflow Prevention Devices

For our overflow prevention systems we supply completely wired electrical cabinets.

Design

The control unit includes:

- Laterally mounted acoustic alarm and main switch
- n x transducer
- 1 x collective acknowledgement unit
- Control unit door with
 - 1 x operation lamp, green
 - n x alarm lamp, red
 - 1 x acknowledgement button for acoustic alarm
- Series terminals for
 - n x level sensor
 - auxiliary power
- Cable ducts

Note

The control unit may not be operated in an explosive atmosphere.

Technical Data

- Protection type of housing: IP 55
- Housing material: steel, varnished
- Colour: grey
- Auxiliary power: 230 V, 50 Hz
- Cable ducts: PG 11
- Dimensions: given by the number of transducers

Purchase Order Codes

Please state the following order number in your purchase order.

Accessories

Auxiliary power	230 V AC	1		
	110 V AC	2		
	24 V AC	3		
	24 V DC	4		
Order number Acknowledgement unit QE 200		3390	1	
Number of inputs	10	1		
	25	2		
Order number Collective acknowledgement unit SAM 8 / 25		3390	2	
	230 V / 50 Hz	1		
	24 V / 50 Hz	2		
	24 V / DC	3		
Acoustic alarm type HPW 110		1		
Acoustic alarm with integrated alarm lamp HR		2		
Order number Acoustic alarms		3390	3	
Alarm lamp type W (lamp excl.)		8		
Alarm lamp type R4		9		
Order number Optical alarms		3390	3	0
Test gas container	82T: 1 litre, 200 bar, nitrogen	1		
	92T: 2 litres, 10 bar, to be filled	2		
Order number Testing device		3390	4	
Order number Counter-plug type S28 for electrical plug connection		9030	1	0
Rack	unwired	1	0	
	wired with cable connection (5 m) right-hand (rear view)	1	1	
	wired with cable connection (5 m) left-hand (rear view)	1	2	
Plastic housing	IP 40	2	1	
	IP 65	2	3	
Female connector according to DIN 41612 model F		3	0	
Order number Components for 19" boards (European boards)		9020	1	
Number of connected level detectors	Quantity (e. g. 5 pcs. = 0 5)			
Alarm	Acoustic alarm	1		
	Acoustic alarm, alarm lamp	2		
Order number Control unit		9010		

For further information contact us on telephone +49/40/39 82 07-0

Current information under: www.fafnir.com

