

UM 2.1/UM 2.2/UM 2.3

Measurement evaluation units



02/2002
Edition: 1

© Copyright:

Reproduction and translation only with the written consent of the company FAFNIR.
FAFNIR reserves the right to carry out product alterations without prior notice.

Art. Nr. 207076

Table of Contents

1	Characteristic features of the measurement evaluation units UM 2.1, UM 2.2 and UM 2.3	4
2	Safety instructions	5
3	Structure and mode of operation	6
	Measurement evaluation unit UM 2.1	6
	Measurement evaluation unit UM 2.2	7
	Measurement evaluation units UM 2.3 U and UM 2.3 I	8
4	Installation	9
	Measurement evaluation unit UM 2.1	12
	Setting limit values	12
	Measurement evaluation units UM 2.3 U and UM 2.3 I	13
	Configuring measurement evaluation units ...	13
	Control buttons and numeric display	14
	Configuring parameters	14
	Verifying configuration	17
	Error messages	17
	Setting limit values	18
5	Technical data	19
	Measurement evaluation unit UM 2.1	19
	Measurement evaluation unit UM 2.2	19
	Measurement evaluation unit UM 2.3 U and UM 2.3 I	20

1 Characteristic features of the measurement evaluation units UM 2.1, UM 2.2 and UM 2.3

The measurement evaluation units UM 2.1, UM 2.2 and UM 2.3 U / UM 2.3 I are used for evaluating and displaying levels of liquids in tanks. The levels measured and transferred to the measurement evaluation units are processed in such a way that they can either be read off a display on the measurement evaluation units or have an electrical output:

- UM 2.1 indicates the level in the form of a bar display and outputs two freely definable limit values via changeover contacts.
- UM 2.2 provides an output of 0/4–20 mA and an output of 0–10 V in proportion to filling level.
- UM 2.3 U / UM 2.3 I is microprocessor-controlled and indicates the level via an LED numeric display in litres. As with measurement evaluation unit UM 2.1, two limit values can be freely defined and be output via changeover contacts.

Any level sensors with a 0–10 V output can be connected up to measurement evaluation units UM 2.1, UM 2.2 and UM 2.3 U. The measurement evaluation unit UM 2.3 I is designed for level sensors with a 4–20 mA output. The measurement evaluation unit UM 2.3 I is designed for level sensors with a 4–20 mA output.

At the same time measurement evaluation units have a voltage supply for continuous level sensors.

2 Safety instructions

The measurement evaluation units UM 2.1, UM 2.2, UM 2.3 U, or UM2.3 I serve the purpose of measuring and evaluating the filling levels in tanks. Use the system for this purpose only. The manufacturer shall not be liable for any form of damage resulting from improper use!

The measurement evaluation units were developed, manufactured and inspected in accordance with state-of-the-art technology and with recognised technical safety rules and regulations. Nevertheless, hazards may arise from the use of these devices. Therefore, observe the following safety instructions.

Do not change or modify the system or add any equipment without the prior consent of the manufacturer.

Use original replacement parts only. These comply with the technical requirements specified by the manufacturer.

The installation, operation and maintenance of the measurement evaluation unit is only allowed to be carried out by expert, authorised personnel. Specialised knowledge must be obtained by undergoing regular training.

Operators, installers and service personnel must observe all applicable safety regulations. This also applies to the local safety regulations and accident prevention regulations not mentioned in this manual of operating instructions.

The measurement evaluation units are not suitable for outdoor installation.

The safety instructions in this instructions manual are labelled as follows:



If you do not observe these safety instructions, risk of an accident exists or the measurement evaluation units could be damaged.



Useful information that will guarantee proper function of the system or facilitate your work.

3 Structure and mode of operation

Measurement evaluation units UM 2.1, UM 2.2 and UM 2.3 U/UM 2.3 I contain the power supply and signal evaluation for the connected level sensor.

Measurement evaluation unit UM 2.1

Measurement evaluation unit UM 2.1 has a light-strip indicator with 5% increments for displaying the levels in the tank (1).

With the Test button (4) and three potentiometers (5) at the bottom of the measurement evaluation unit two limit values can be set.

The operating state of the measurement evaluation unit is indicated by three LEDs (LEDs). The green LED „Operation“ (3) is lit when UM 2.1 is connected to the power supply and ready for operation. The two yellow LEDs „GS 1“ and „GS 2“ (2) are lit when the defined limit values 1 and 2, respectively, have been reached.

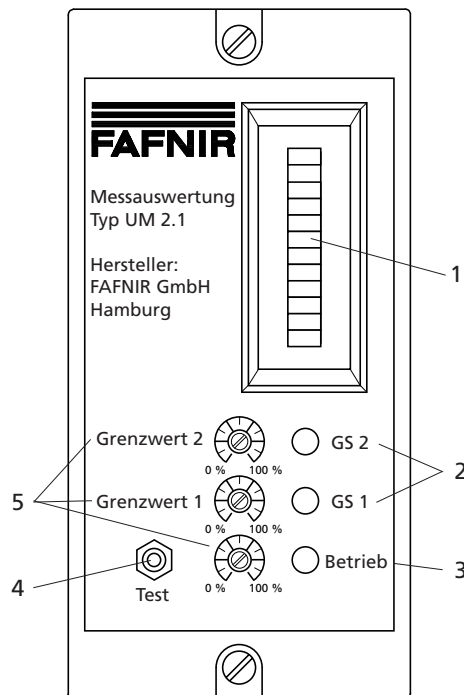

Fig. 1a: Measurement evaluation unit UM 2.1

Measurement evaluation unit UM 2.2

Measurement evaluation unit UM 2.2 provides an output of 0/4–20 mA and an output of 0–10 V proportional to filling level.

The green LED „Operation“ (1) is lit when the UM 2.2 is connected to the power supply and is ready for operation.



Fig. 1b: Measurement evaluation unit UM 2.2

Measurement evaluation units UM 2.3 U and UM 2.3 I

Measurement evaluation units UM 2.3 and UM 2.3 I have a 4-digit numeric display for indication the levels in the tank (1). With the aid of the plus (2) and ok buttons (7) at the top of the measurement evaluation unit the unit can be configured and matched to respective tank data.

With the Test button (5) and three potentiometers (6) at the bottom of the measurement evaluation unit two limit values can be set.

The operating state of the measurement evaluation unit is indicated by three LEDs (LEDs). The green LED „Power“ (4) is lit when the measurement evaluation unit is connected to the power supply and is ready for operation. The two yellow LEDs „L 1“ and „L 2“ (3) is lit when the respective defined limit value 1 or 2 (Level 1 and 2) has been reached.

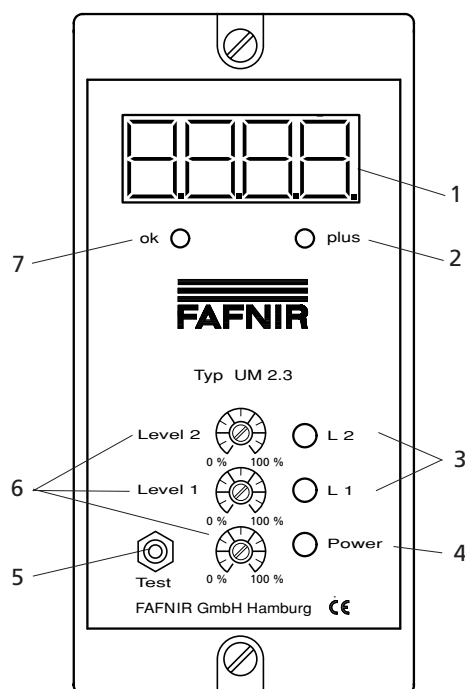

Fig. 1c: Measurement evaluation unit UM 2.3

4 Installation

The measurement evaluation units are integrated into a plastic housing with IP 40 protection and must be installed in a weatherproof location. The permissible ambient temperature is between -20 °C and +40 °C.



Carry out the wiring work only when the unit is in its de-energised state. Switch off the 230 V power supply system before opening the measurement evaluation unit. The power supply system is only allowed to be switched on only when the measurement evaluation unit has been firmly screwed together.



For any work being carried out on the measurement evaluation unit, the relevant technical safety regulations and accident prevention regulations of the professional associations as well as the VDE (German association of electricians) regulations or the corresponding national provisions for the electrical connection work must be observed.

To connect up measurement evaluation units UM 2.1, UM 2.2, UM 2.3 U and UM 2.3 I:

1. Undo two screws with which the housing is attached to the base and detach the housing.



2. Connect up measurement evaluation unit in accordance with Figs. 2a, 2b, 2c and 2d.

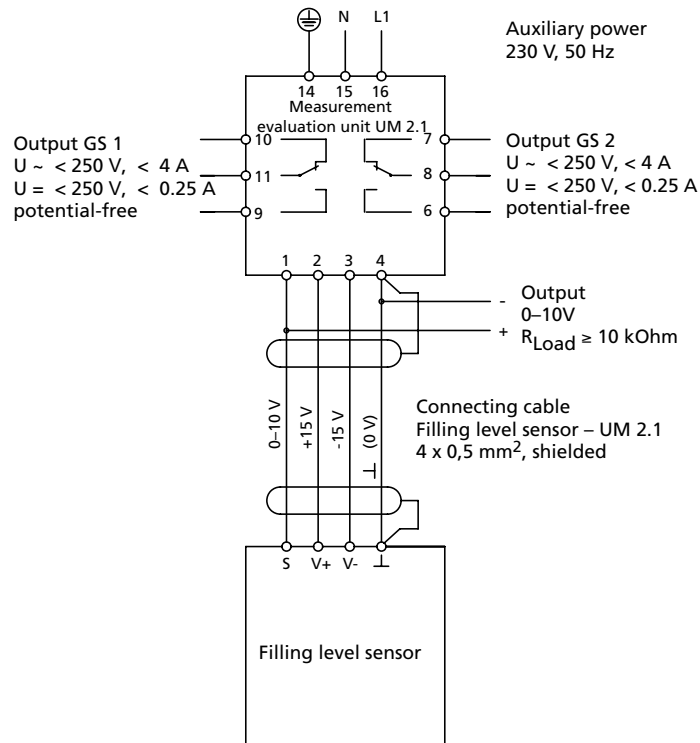

Fig. 2a: Connection of the measurement evaluation unit UM 2.1

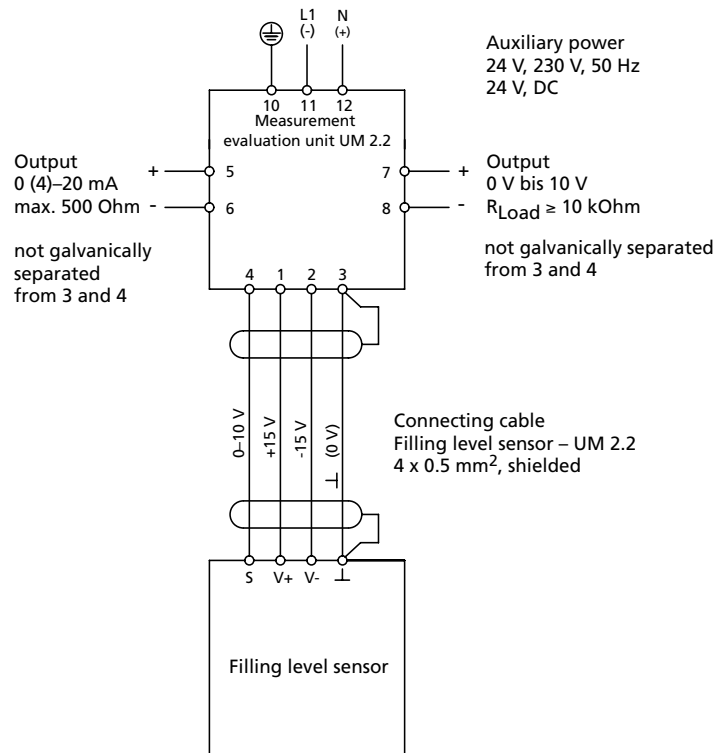

Fig. 2b: Connection of the measurement evaluation unit UM 2.2

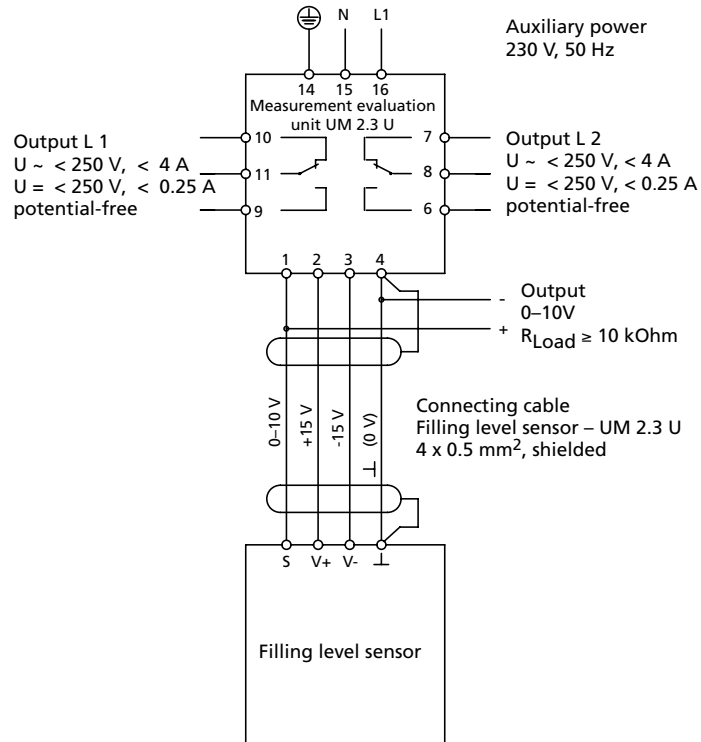

Fig. 2c: Connection of the measurement evaluation unit UM 2.3 U

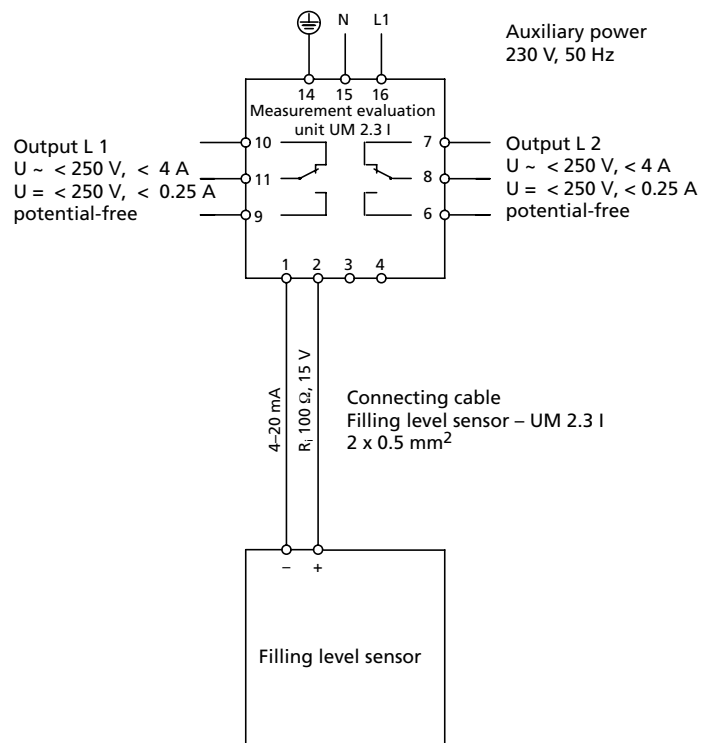

Fig. 2d: Connection of the measurement evaluation unit UM 2.3 I

3. Replace the housing and screw it on.
4. Finally turn on the power supply.
The green LED „Operation“ and „Power“ are lit.



Measurement evaluation unit UM 2.2 is now ready for operation. Measurement evaluation unit UM 2.3 still has to be configured and matched to the respective tank data. Finally, the two limit values are set on measurement evaluation units UM 2.1 and UM 2.3.

Measurement evaluation unit UM 2.1

Setting limit values

To set the limit values on the measurement evaluation unit UM 2.1 (see Fig. 3):

1. Press and hold down the test button (5) on the measurement evaluation unit.
2. Simulate an input voltage (filling height) via the lower potentiometer (4). This is then displayed on the light-strip indicator (1) (in %).
3. Adjust the desired limit signal potentiometer (6 or 7) so that the corresponding limit signal relay responds at the simulated filling height. This is then indicated via the light-emitting diodes (2 or 3) next to the limit signal potentiometers.



The limit signal relay 1 responds when the filling height is not reached and relay 2 when the filling height is exceeded. In order to prevent any form of fluttering of the limit signal outputs, these limit signal outputs possess a hysteresis of approx. 3 %. If, e.g. the limit signal 1 is adjusted to 20 % filling height, the relay responds at 20 %

and switches off again when the filling height is exceeded with a value of 23 %.

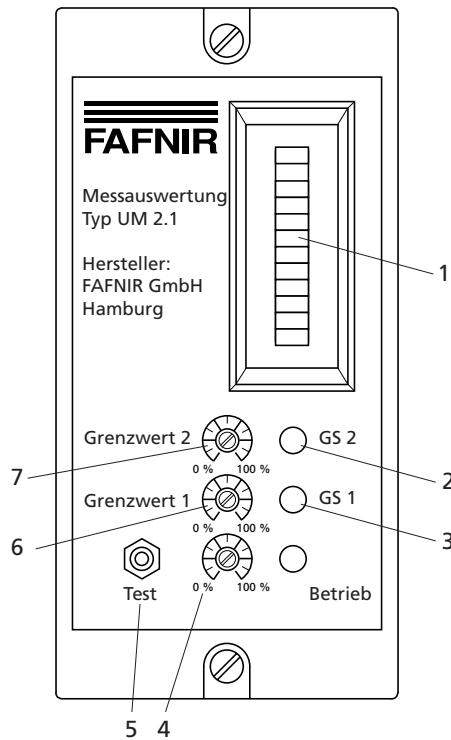

Fig. 3: Measurement evaluation unit UM 2.1

Measurement evaluation units UM 2.3 U and UM 2.3 I

Configuring measurement evaluation units

When the measurement evaluation unit has been connected up to the level sensor and the power supply, it has to be configured for correct indication of the level of liquid and hence for the respective tank data.

The following parameters are configured in this order:

1. Decimal point (on the display)
2. Decimal point (on the display)
3. Tank design
4. Tank volume
5. Tank height
6. Current filling level

Control buttons and numeric display

Configuration is performed with the aid of the two buttons „plus“ and „ok“:

 plus Increase activated digit (flashing) by one

 ok Confirm and activate next digit (flashing)

The values to be configured are shown on the numeric display :

 Digit irrelevant

 Digit activated for input (flashing), to be changed

 Digit entered and already confirmed with ok button

Rounding, position of the decimal point and the **design of tank** are entered when the first decimal point is lit.



Enter the **tank volume** when the first and second decimal points are lit.



Enter the **tank height** when the first, second and third decimal points are lit.





Enter the **current filling level** when all four decimal points are lit.



Configuring parameters

To configure measurement evaluation units UM 2.3 U and UM 2.3 I:

- Press ok  and plus  buttons simultaneously. The setting mode of the measurement evaluation unit is activated.

The first digit on the display flashes (is activated) and the first decimal point is lit.



1. Decimal point (on the display)

The last digit(s) of the filling level is/are automatically shown on the numeric display in an appropriately rounded down format. Depending on the tank volume programmed the display is generally rounded to nearest 10 or 5 units in order to stabilise the digital value.

For special applications however, e.g. large-volume tanks, it is also possible to configure a different setting according to the following numeric code:

0	Factory setting	automatic rounding
1	1-incr rounding	No rounding
2	2-incr. rounding	in 2-incr. increments of 2 (to even values)
3	5-incr. rounding	in 5-incr. increments of 5 (to 0 and 5)
4	10-incr. rounding	in 10-incr. increments
5	20-incr. rounding	in 20-incr. increment



If the value displayed constantly changes, rounding is configured too low and hence too finely for the measuring accuracy of the measurement evaluation unit. The higher the tank and the measuring accuracy of the level sensor connected, the less need for display stabilisation.



– Set the desired rounding in digit 1 by pressing the plus button .

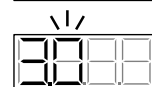

– Confirm setting with the ok button . The value is accepted and the second digit flashes.

2. Decimal point (on the display)

Depending on tank dimensions and field of application the position of the decimal point for the 4-digit numeric display can be defined according to the following numeric code:

0 No decimal point (factory setting)

1 after 1st digit

2 after 2nd digit

3 after 3rd digit



– Set the desired position of the decimal point at digit 2 by pressing the plus button .



– Confirm setting with the ok button . The value is accepted and the third digit flashes.

3. Tank design

To convert the filling level to litres and display the appropriate figure the tank design must be configured in accordance with the following numeric code:

1	Linear tank	Cuboid tanks, vertical cylinders, basement-welded steel tanks
2	Cylindrical tank	Horizontal tanks (steel/buried tanks)
3	Spherical tank	Tanks of approx. spherical shape (buried tanks made of glass-fibre reinforced plastic)
4	Plastic battery tank	Tanks with bands or several vaults
5	Oval tank	Basement tanks (grp/sheet metal tanks)





- 6 Plastic tank with Recess Tanks with large recess at centre of tank (longitudinal battery tanks without bands)
- 7 Semi-circular cistern Horizontal, semi-circular PE rainwater storage tank with flat bottom

- Since the third digit is not relevant to setting, press the ok button  again to activate the fourth digit.
- Press the plus button  to set the appropriate tank design at digit 4.
- Confirm setting with the ok button . The value is accepted, the first digit flashes and the first two decimal points are lit.



4. Tank volume



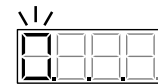

Enter the maximum total volume of the tank as a 4-digit value in litres. If the tank volume is larger than 9999 litres, the value must be entered in cubic metres and the position of the decimal point may have to be adjusted later.

- Select first digit (flashing) with 
 - Confirm first digit with 
 - Select second digit (flashing) with 
 - etc.
 - Confirm fourth digit with 
- The value is accepted, the first digit flashes and the first two decimal points are lit.



5. Tank height

Enter tank height as a 4-digit value in millimetres.

- Select first digit (flashing) with 
 - Confirm first digit with 
 - Select second digit (flashing) with 
 - etc.
 - Confirm fourth digit with 
- The value is accepted, the first digit flashes and the first two decimal points are lit.



6. Current filling level

Enter the current filling level of the tank as a 4-digit value in millimetres. For this the level sensor must have been immersed/ installed beforehand. This setting should be made when the tank is relatively full.



- Select first digit (flashing) with
- Confirm digit with
- Select second digit (flashing) with
- etc.
- Confirm fourth digit with

The value is accepted and the measurement evaluation unit switches back to the display mode automatically. The numeric display presents the current filling volume in litres or m³.

Verifying configuration

After configuring the above parameters the volume of liquid displayed may have to be verified and adjusted if necessary:

1. Establish the volume of liquid in the tank, e.g. with the aid of a sounding stick and a sounding chart.
2. Adjust the value indicated in the display mode if necessary.
 - adjusts value upwards depending on rounding set
 - adjusts value downwards depending on rounding set

When the digits no longer flash, the adjusted value has been accepted.

Error messages

If during configuration an error message (E00X) appears on the numeric display, the error message must be acknowledged after remedying the cause by pressing the ok button . The setting mode automatically switches to the first configuration-stage for re-entry.

Please check your tank data before re-entering.



If you have any questions about error messages please contact the FAFNIR company.

Setting limit values

To set the limit values on the measurement evaluation unit UM 2.3 (see Fig. 4):

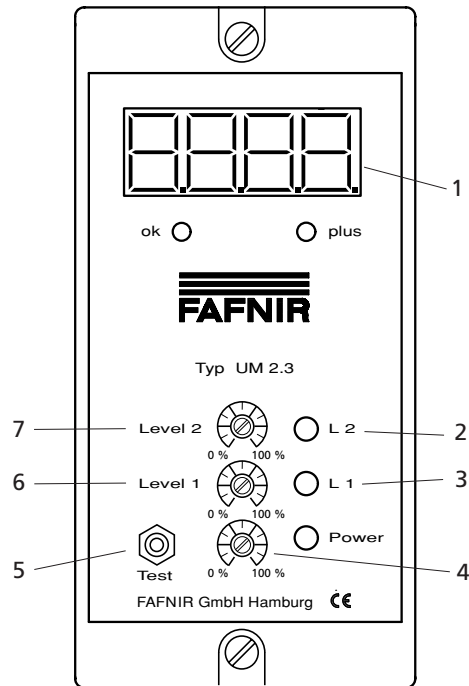

Fig. 4: Measurement evaluation unit UM 2.3

1. Hold down the Test button (5) on the measurement evaluation unit.
2. Using the bottom potentiometer (4) simulate the appropriate input voltage (volume of liquid). The simulated level of liquid is shown on the numeric display (1).
3. Set the required limit signal potentiometer (6 or 7) in such a way that the relevant limit signal relay responds at the simulated volume.
The appropriate yellow LED (2 or 3) on the right next to the limit signal potentiometers is lit.



Limit signal relay 1 responds if the volume of liquid is too low, relay 2 responds if the volume of liquid is too high. To prevent the limit signal outputs from chattering, they have a hysteresis of approx. 3 %. If, for example, limit signal 1 is set to a liquid volume of 20%, the relay responds at 20% and switches off if 23% is exceeded.

5 Technical data

Measurement evaluation unit UM 2.1

Protective system:	IP 40
Auxiliary power:	230 V, 50 Hz
Input:	0 to 10 V DC
Output signal:	0 V to 10 V parallel to signal input 2x floating changeover contact
Display:	red LED light-strip indicator (filling level) resolution 5 %

Measurement evaluation unit UM 2.2

Protective system:	IP 40
Auxiliary power:	24 V or 230 V, 50 Hz, 24 V DC
Input:	0 to 10 V DC
Output signal:	0 (4) to 20 mA and 0 V to 10 V

Measurement evaluation unit UM 2.3 U and UM 2.3 I

Protective system:	IP 40
Auxiliary power:	230 V, 50 Hz
Input:	
UM 2.3 U	0–10 V DC
UM 2.3 I	4–20 mA
Output signal:	2x floating changeover contact
Display:	red LED-numeric display, 4-digit (volume of liquid)